

# Design and study of a low-cost laboratory model digital wind power meter

Rugmini Radhakrishnan<sup>1</sup> and S Karthika

Department of Physics, Avinashilingam University for Women, Coimbatore-641 043, Tamil Nadu, India

E-mail: rugminiradhakrishnan@yahoo.com

## Abstract

A vane-type low-cost laboratory model anemometer cum power meter is designed and constructed for measuring low wind energy created from accelerating fluids. The constructed anemometer is a device which records the electrical power obtained by the conversion of wind power using a wind sensor coupled to a DC motor. It is designed for its high-reliability, ease of construction and for a wide profile of low-range velocities. The construction of the digital anemometer is an easy task that even unskilled people can manage in a short time. The performance of the digital anemometer is analysed by its capability to convert wind speeds to power.

 Online supplementary data available from [stacks.iop.org/physed/45/581/mmedia](http://stacks.iop.org/physed/45/581/mmedia)

## Introduction

An anemometer is a device for measuring wind speed. The term is derived from the Greek word, *Anemos*, meaning 'wind'. Anemometers make use of pressure, kinetic energy or the cooling power of the wind to measure its speed. A wind measuring system consists of sensors, signal conditioning units and a display or recorders (Mani 1995). The apparatus allows the measurement of wind velocity irrespective of the wind direction and at the same time allows easy recording (Bansal *et al* 1990). Wind field modification due to the anemometer tower shows the variations in wind velocity (Lavagnini *et al* 1988). A simple hot wire anemometer made from a combination of straight platinum wires for the measurement of wind

direction (Gjessing *et al* 1969) is described. A theoretical study of a vane anemometer estimated the mean values for sinusoidally fluctuating winds (Ramachandran 1969).

A digital anemometer can measure both the speed and direction of wind in two dimensions (Hernandez-Walls *et al* 2008).

A low-cost vane-type laboratory model anemometer cum power meter is constructed for measuring low wind energy created from accelerating fluids. Anemometers are wind power measuring instruments used to collect wind data. Commercial anemometers are of different types; we aimed to make a low-cost power meter for distinct measurement of power from wind. A microcontroller-based digital anemometer was constructed and found to be very efficient at measuring low wind power.

<sup>1</sup> Author to whom any correspondence should be addressed.

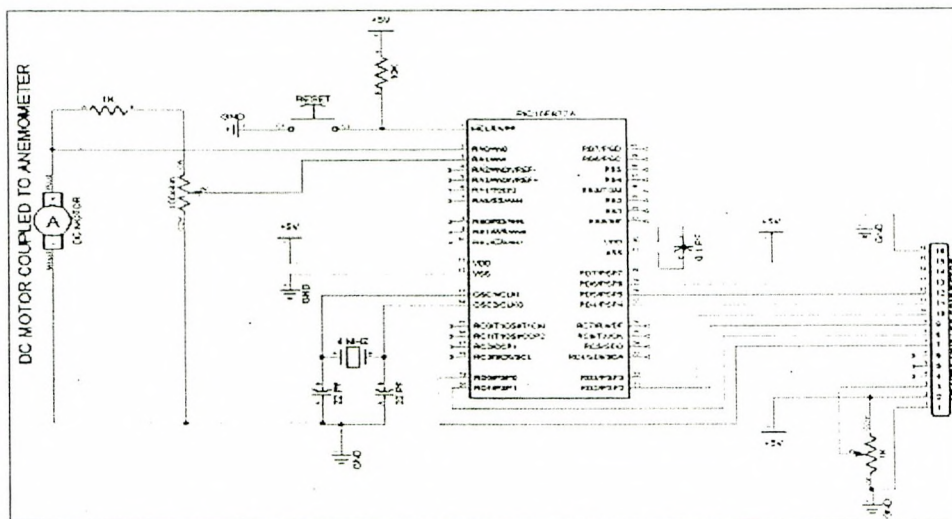

Figure 1. Circuit diagram.

**Objectives**

- To construct a digital anemometer cum power meter by integrating a microcontroller-based program.
- To study the program coding techniques for digital display.
- To study the performance of the constructed wind power meter by testing its reliability with a dual power supply (both AC and DC).

- Data memory (in bytes): 368.
- EEPROM Data memory (in bytes): 256.
- Interrupts: 15.
- I/O ports: A, B, C, D, E.
- Timers: 3.
- Analogue comparators: 2.
- Instructions: 35.

**Methodology**

A PIC 16F877A microcontroller, as the major component, and other electronic components such as transformers, resistors, capacitors, LEDs (light emitting diodes) and LCDs (liquid crystal display) are used in the construction of the wind power meter.

**PIC 16F877A microcontroller**

PIC means peripheral interface controller. The PIC families have different series. The series are 12-series, 14-series, 16-series, 18-series and 24-series. With a PIC 16F877A microcontroller, the circuit works on a 16-series system.

**Operational data of a PIC microcontroller**

- Operating frequency: DC-20 MHz.
- Flash program memory (14 bit words): 8 K.

**Circuit operation**

The circuit diagram is shown in figure 1. The microcontroller and LCD operate at +5 V dc. Therefore, the 230 V AC voltage supplied from the mains is stepped down to +5 V using a step down transformer and converted to DC power by the full wave bridge rectification method. The output DC power may contain some ripples and these ripples are filtered using filter circuits (capacitors). The constant +5 V output is regulated using an IC7805 voltage regulator. The output of the 7805 regulator is given to the PIC microcontroller and LCD. A 4 MHz crystal oscillator is used to generate the clock pulses to the PIC microcontroller. The speed of the microcontroller depends upon the value of the crystal oscillator. The output voltage generated in the DC motor rotation depends upon the wind power. Thus the generated output is varied depending upon the wind energy. When the DC motor shaft is connected with the rotating blades powered by wind energy, DC power output

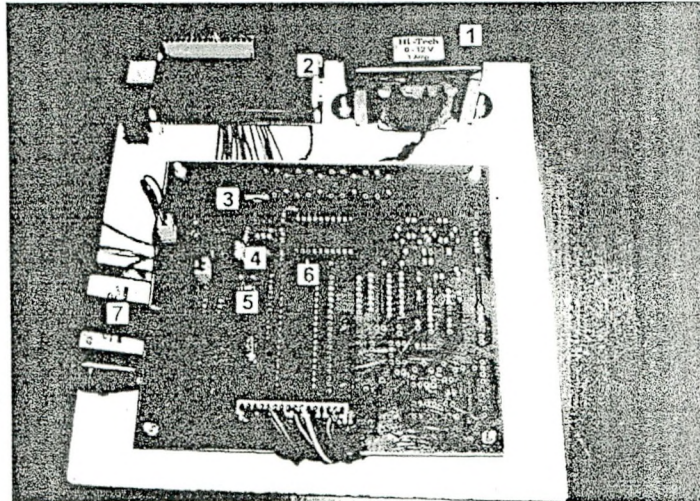

Figure 2. Electronic assembly of the anemometer. (1) Transformer: (2) LCD: (3) capacitor: (4) LED: (5) resistor: (6) microcontroller 16F877A: (7) battery.

is produced at the stator terminal of the DC motor. This generated power is converted to voltage by connecting a shunt resistor parallel to the output. This converted output analogue voltage is given as input to the Ra0 pin of the microcontroller ADC input. Through the program coding techniques the analogue voltage is converted to digital format to display the actual wind power generated in milliwatts rating in the LCD display. The LCD display is connected to the output PORT C and PORT D to provide a signal to change the variation according to the change in input. The connections are made and the digital anemometer is assembled as shown in figure 2.

### Performance analysis

The digital vane-type anemometer assembled with reference to the circuit given in figure 2 is tested for its proper working under AC as well as DC power supply. First the device is switched on with an AC supply and, keeping the turbine of the anemometer at various distances from the source of wind, the power generated by the wind is measured as displayed on the display segment. The source of wind is a regulated electric fan. The wind speed from the electric fan is sensed by the wind sensor (blades) which is shown in figure 3. The blades rotate at a speed proportional to the wind speed and the DC motor coupled with the wind sensor converts it into electrical energy. The

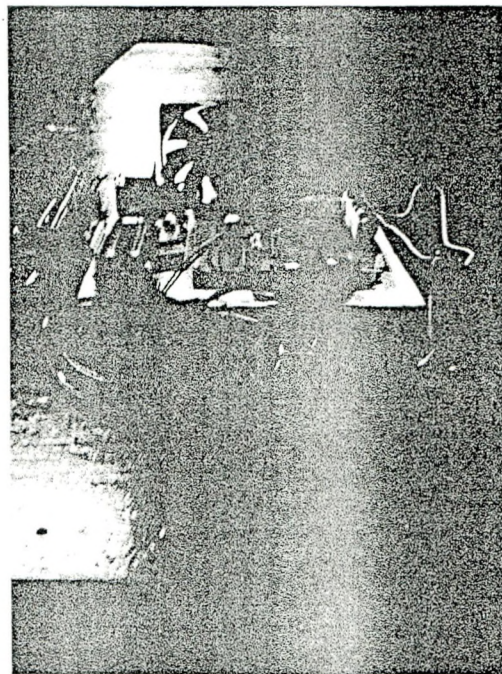

Figure 3. Schematic of the anemometer cum power meter.

wind power produced due to the rotation of the anemometer blades is measured by connecting the probes from the corresponding pins of the display to the leads of the motor shaft coupled to the

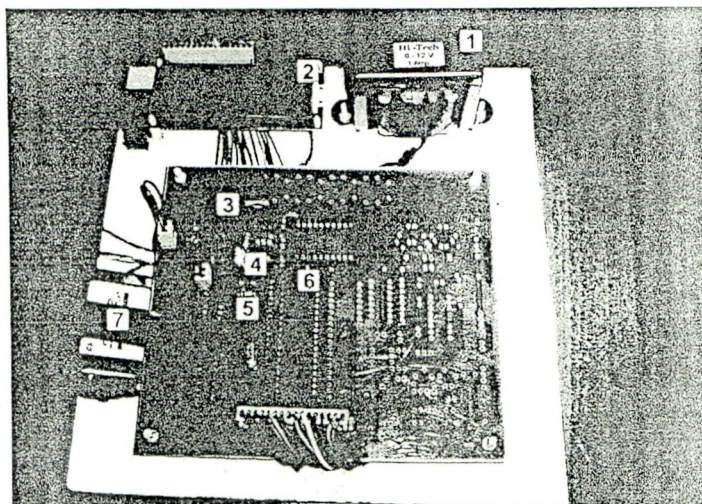

Figure 2. Electronic assembly of the anemometer. (1) Transformer; (2) LCD; (3) capacitor; (4) LED; (5) resistor; (6) microcontroller 16F877A; (7) battery.

is produced at the stator terminal of the DC motor. This generated power is converted to voltage by connecting a shunt resistor parallel to the output. This converted output analogue voltage is given as input to the Ra0 pin of the microcontroller ADC input. Through the program coding techniques the analogue voltage is converted to digital format to display the actual wind power generated in milliwatts rating in the LCD display. The LCD display is connected to the output PORT C and PORT D to provide a signal to change the variation according to the change in input. The connections are made and the digital anemometer is assembled as shown in figure 2.

### Performance analysis

The digital vane-type anemometer assembled with reference to the circuit given in figure 2 is tested for its proper working under AC as well as DC power supply. First the device is switched on with an AC supply and, keeping the turbine of the anemometer at various distances from the source of wind, the power generated by the wind is measured as displayed on the display segment. The source of wind is a regulated electric fan. The wind speed from the electric fan is sensed by the wind sensor (blades) which is shown in figure 3. The blades rotate at a speed proportional to the wind speed and the DC motor coupled with the wind sensor converts it into electrical energy. The

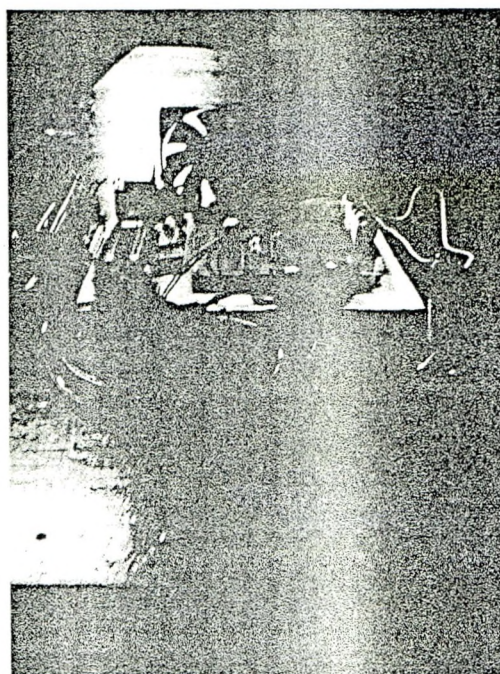

Figure 3. Schematic of the anemometer cum power meter.

wind power produced due to the rotation of the anemometer blades is measured by connecting the probes from the corresponding pins of the display to the leads of the motor shaft coupled to the

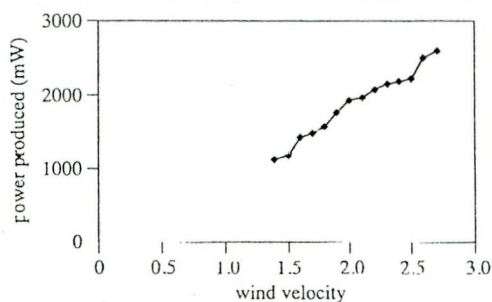

Figure 4. Variation of power with wind velocity (AC supply).

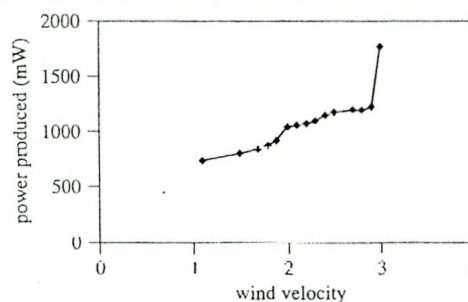

Figure 5. Variation of power with wind velocity (DC supply).

turbine. The turbine speed is recorded with the help of a reference anemometer. The device is placed at various distances from the source of wind at fixed positions and the power produced is noted.

The experiment is also repeated with a DC supply by using the battery incorporated in the circuit assembly in the absence of an AC supply. The observations are taken by keeping the turbine at various distances from the source of wind to record the velocity of the wind and the corresponding power produced. Thus, the performance of the designed digital anemometer is analysed both with AC and DC supplies.

### Results and discussion

The performance of the constructed digital anemometer is tested first with an AC supply. After giving the power from the AC supply, the shrouded blades of the turbine of the anemometer are subjected to a source of wind produced from a regulated electrical fan. As the blades of the turbine are rotated, electrical energy is generated in the coupled motor and the probes from the turbine set up are used to measure the power delivered in milliwatts, as recorded in the display segment of the assembly. The speed of rotation of the turbine due to the wind from the fan is recorded simultaneously by another reference digital anemometer by keeping its vanes at the same level and position as the shrouded turbine of the constructed device. The observations of the power delivered for various wind speeds using an AC supply are represented in figure 4. The observations indicate that the power delivered depends upon the wind speed and it confirms the principle of any vane-type anemometer.

Now, the constructed device was put into operation with a supply of DC power from batteries incorporated in the assembly by inserting the leads into the socket of the DC supply and the experiment is repeated as done with the AC supply. A number of observations were taken by keeping the turbine at different distances from the source for different wind speeds and power delivered from the DC supply, as depicted in figure 5.

The values obtained with a DC supply are observed to be less than those with an AC supply. This may be due to the discharge of the battery delivering the input power for working the device. Thus, it is ascertained that better performance is obtained with an AC supply of constant voltage. In general, the constructed anemometer is efficient in operation to study the power delivered due to the wind speed.

### Highlights of the study

- It is very simple and easy to construct as it is based on electronic circuits.
- It is assembled with electronic components such as resistors, capacitors, LCDs, a microcontroller 16F877A etc, and the total cost of the device is Rs 2000 only.
- It gives satisfactory performance for the measurement of power delivered due to wind.
- It is a device capable of operating both with AC and DC power supplies.
- It is very compact and easy to transport.
- It can be operated in areas with remote access to grid supply.
- Since the option of battery operation is there, it can be very easily used in the case of power failure.

- It is a highly sensitive device and is also very cheap, compared with commercial anemometers.

### Conclusion

Anemometers play a vital role in all wind energy measurements. High-tech commercial anemometers are highly sophisticated and expensive, so cheap and efficient anemometers to measure wind power directly from the wind speed are very welcome. Our attempt to construct an inexpensive microcontroller-based anemometer for measuring the direct power from the wind turned out to be successful. The functioning of the device with either AC or DC is an added advantage for using it in outdoor experimentation in areas of remote grid supply. This easy, compact, portable and cheap electronic power anemometer was found to be efficient and gave better than expected results. Though it is not sophisticated, this type of power anemometer is useful in laboratory experiments and also as a demonstration model.

Received 3 December 2009, in final form 4 May 2010  
doi:10.1088/0031-9120/45/6/001

### References

- Bansal N K, Kleemann M and Meliss M 1990 *Renewable Energy Source and Conversion Technology* (New Delhi: Tata McGraw-Hill) pp 364–6
- Gjessing D T, Lanes T and Tangerud A 1969 A hot wire anemometer for the measurement of the three orthogonal components of wind velocity, and also directly the wind direction, employing no moving parts *J. Phys. E: Sci. Instrum.* **2** 51–4
- Hernandez-Walls H, Rojas-Mayoral E, Baez-Castillo L and Rojas-Mayoral B 2008 Design and calibration of an inexpensive digital anemometer *Phys. Educ.* **43** 593–8
- Lavagnini A, Argentini S and Carcullo R 1988 Wind field modification due to an anemometer tower *Nuovo Cimento C* **11** 619–27
- Mani A 1995 *Wind Energy Resource Survey in India-I* (New Delhi: Allied Publishers) pp 174–5
- Ramachandran S 1969 A theoretical study of cup and vane anemometers part II *Q. J. R. Meteorol. Soc.* **96** 115–23

**Rugmini Radhakrishnan** has a keen interest in research into energy utilization and renewable energy products and in designing simple, novel electronic devices for measurement of energy output. Simple solar updraft towers, hybrid anemometers, solar cell phone chargers, integrated greenhouse solar cookers and the development of materials for fuel cells are all part of her research.