

**AUTOMATIC INDOOR HOME MONITORING SYSTEM USING
SMART TECHNOLOGIES BASED ON GREEN ENERGY**

BY

PREETHI B

(17PCS017)

Project Report Submitted

In Partial fulfillment of the requirements for the award of

Master's Degree in Computer Science

Department of Computer Science

**Avinashilingam Institute for Home Science and Higher Education
for Women, (Deemed to be University)**

Coimbatore-641043

April - 2019

**AUTOMATIC INDOOR HOME MONITORING SYSTEM USING
SMART TECHNOLOGIES BASED ON GREEN ENERGY**

**BY
PREETHI B
(17PCS017)**

**Project Report Submitted
In Partial fulfillment of the requirements for the award of
Master's Degree in Computer Science**

**Department of Computer Science
Avinashilingam Institute for Home Science and Higher Education
for Women, (Deemed to be University)
Coimbatore-641043
April - 2019**

Signature of the Head of the Department

Signature of the Supervisor

Viva Voce Examination Held on: _____

Signature of the Examiner

Acknowledgment



ACKNOWLEDGMENT

I would like to express my sincere thanks to **God Almighty**, for his constant love and grace that he has showed upon me, which kept me in good health, and sound mind without which my project would not have reached a successful end.

I would like to express my deep sense of reverential gratitude and sincere thanks to **Shri.,Dr. P. R. Krishnakumar., Chancellor**, Avinashilingam Institute of Home Science and Higher Education for Women, Coimbatore, for the opportunity given to me for undertaking this study and for providing the needed facility during the course of my study.

I owe my great deal of gratitude to **Dr. Premavathy Vijayan, Vice Chancellor**, Avinashilingam Institute for Home Science and Higher Education for Women, Coimbatore, for extending all resources that facilitated the conduct of the present study.

I express my gratitude to **Dr. (Mrs.) S. Kowsalya, Registrar**, Avinashilingam Institute for Home Science and Higher Education for Women, Coimbatore, for providing all facilities necessary for the study.

I would express my boundless thanks to **Dr. (Mrs.) K. Udaya Chandrika, Dean, School of Physical Sciences and Computational Sciences**, Avinashilingam Institute for Home Science and Higher Education for Women, Coimbatore, for granting the facility required.

I wish to place on record my deep sense of gratitude to **Dr. (Mrs) V. Radha, Professor and Head, Department of Computer Science**, for providing all the facilities to complete the project.

I heartily thank my esteemed project guide **Dr. (Mrs). N. Valliammal, Assistant Professor (SS), Department of Computer Science**, for imparting the tremendous assistance and well-timed support for triumph of my project.

I wish to place my deep sense of gratitude to **Dr. P. Subashini, Professor**, and **Dr. M. Krishnaveni, Assistant Professor, Department of Computer Science**, for their guidance and providing necessary resources for the project.

I express my sincere acknowledgement to **DST-SERB** entitled “**Technology Development for the Support and Improvement of Speech Language Impaired People**” for providing financial help to complete my degree.

I would like to express my sincere gratitude to **Prof. Aawatif HAYAR, President of GreenTic Research Center, University Hassan II Casablanca, Morocco**, for inviting and make a Team Member from India in the **Solar Decathlon Africa** Competition and providing an opportunities to develop a technology model to integrate in the **ECO-DAR** House.

I wish to place on record my deep sense of gratitude to **GREENTIC India Chapter** for providing support for the project and make to publish a Research Paper in the International Conference.

I express my honorable thanks to my project coordinator **Dr. (Mrs.) G. Padmavathi, Professor, Department of Computer Science**, for her kind advice and knowledgeable suggestions which helped us to complete my project successfully.

I would like to express my deep thanks to **Ms. T. T. Dhivya Prabha, PhD and Research Assistant, Ms. R. Shanmugavalli, PhD Scholar, Ms. M. Manjutha, PhD Scholar, and R&D Team Members** for helping me in various line of mode.

Finally, yet importantly, I would like to thank **my family members and friends** for their support, encouragement and prayers, which were instrumental in the successful completion of this project. I have great pleasure in expressing my deep sense of gratitude to all other teaching and non-teaching staff members who stood behind the screen for the completion of the project. I would extend my hearty thanks to one and all that helped me directly or indirectly for the successful completion of my project.



Synopsis

SYNOPSIS

The developments on Home Automation System are very popular in the recent decades. IoT is providing a major role in the smart home, where the devices are connected to the internet and communicate with the user in different way. Microcontroller acts as an interface to the devices and the other technologies, like bluetooth control, wireless control, etc., is providing added advantages for making the house control automated. In addition to it, energy consumption using the green technology is cost effective in generating the electricity via the renewable resource, which is utilized in the Home Automation System. Solar energy is one of the green energy, which is the main source considered for solar houses. Some of the parameters that changes in the indoor environment are, like quality of the air, temperature, humidity, etc, which will make the person to stay inconvenient. It may also cause some health issues for the people, like, asthma, cold, fever, etc.

This proposed system is to create a solar based IoT monitoring system based on smart technologies, like web technology, mobile application and wireless technology. It will measure the humidity, temperature, light intensity and air quality level of the living room using the various sensors; they are DHT11 sensor, Digital LDR sensor and the MQ135 gas sensor. The sensor data are sent to the webserver and monitored through a ThinkSpeak website via wireless mode using the ESP8266 Wi-Fi module connected to Arduino Microcontroller. The data monitoring and the alert process are carried out in the developed mobile, which is created using the Virtuino Software. The system will provide a user friendly platform for easy interact with the house holders, to monitor the home.

Table of Contents



TABLE OF CONTENTS

S.NO	CONTENTS	PAGE NO
1	INTRODUCTION	
	1.1. Home Automation System	1
	1.2. Green Technology for Smart Home	1
	1.2.1. Solar Power	2
	1.3. Problem Definition	2
	1.4. Overview of the Project	3
2	SYSTEM CONFIGURATION	
	2.1. Hardware Specification	5
	2.2. Software Specification	5
	2.3. Storage	5
	2.4. About the Hardware	6
	2.5. About the Software	14
	2.6. About the Cloud	16
3	SYSTEM STUDY	
	3.1. Existing System	18
	3.2. Proposed System	19
4	SYSTEM DESIGN AND METHODOLOGY	
	4.1. Input Design	23
	4.2. Output Design	24
	4.3. Module Description	25

	4.3.1. Hardware Connection	25
	4.3.2. Arduino and Sensor Data Collection	29
	4.3.3. Data Visualization	29
	4.3.4. Mobile Application Development	29
5	RESULTS AND DISCUSSION	
	5.1. Results	31
	5.2. Module Testing	34
	5.3. Integration Testing	35
	5.4. System Testing	35
6	CONCLUSION	36
7	SCOPE FOR FUTURE DEVELOPMENT	37
8	BIBLIOGRAPHY	38
9	APPENDIX	
	9.1. Circuit Diagram	40
	9.2. Module Connection	44
	9.3. Module Testing Result	46
	9.4. Module Integration Result	48
	9.5. System Testing Result	49
	9.6. Data Visualization	51
	9.7. Mobile Application	54
	9.8. Sample Code	55

Introduction



1. INTRODUCTION

1.1. HOME AUTOMATION SYSTEM

The shelter was one of the most important fundamental need, for the human to live in the world, no matter how it is and how it is constructed. But everyone will have a shelter to take rest, relax, enjoy with family, learn, grow and etc. The Home Automation provides the person to access the home appliances using the mobile devices from anywhere at any anytime by the house owners. So that, the person can stays convenient and comfort in the home for long time. The energy is also effectively maintained on the Smart home. This is done by connecting the devices to the sensors, communicating modules and the microcontroller, which can be controlled using the wireless mode. Some of the advantages of using the smart home are listed here.

- 1. Managing all of the home appliances from one place**
- 2. Remote control of home functions**
- 3. Increased energy efficiency**
- 4. Improved appliance functionality**
- 5. Convenience**
- 6. Comfort**

1.2. GREEN TECHNOLOGY FOR SMART HOMES

With today's drastic increase in energy demand, it becomes more and more important to use alternative green technologies. Solar, wind, and hydroelectricity are popular choices, because they are abundant and cause low pollution. One big challenge however is how to manage these new energy resources within the traditional electricity grid. Today's smart home technologies and devices offer a variety of house appliances with embedded sensors. Through Internet websites or ad hoc applications, customers are able to monitor household appliances and receive data from the sensors in real time. Green renewable source of energy has been utilized in power generation for the functioning of all the smart appliances used to sustain the automated home.

1.2.1. SOLAR POWER

Solar power is the conversion of energy from the sunlight using the photovoltaic solar panel. The photovoltaic module is packed and connected assembly of typically 6x10 photovoltaic solar cells. The photovoltaic cells will produce the electricity, when the chemical reaction happened with the silicon crystal and the sun light. The mono-crystal silicon is covered into the sheet with the mirror, for observing the sunlight. It is classified into 4 types,

- a. Active
- b. Passive
- c. Direct
- d. Indirect

The major disadvantage of using the solar power is, the panel cannot generate the power on the winter and after sunset. Because the sunlight will become low so it cannot generate power for the absorption. The significant is overcome in this project by saving the power in the restorable battery, where the extra power will be stored on the battery so that at night the person can use the power.

1.3. PROBLEM DEFINITION

Planning to building a Solar Powered House is very challenge to the people and using the energy in efficient way is also a biggest confront. The Solar panel will generate the power by using the sunlight, which will available on the day time. After the sunset, the person needs to use the battery power which is store from the solar panel on day time. Automating the home appliances will make efficient use of the electrical energy in the house. The automation will carry on Air Conditioner, Lights, TV, etc.

To overcome the problem, a solar based IOT Home Monitoring system, which is created using Smart technologies based on the solar power, that make the user to stay comfort and convenient in living and also help to utilize the energy efficiently for the home appliances.

1.4. OVERVIEW OF THE PROJECT

The “**AUTOMATIC INDOOR HOME MONITORING SYSTEM USING SMART TECHNOLOGIES BASED ON GREEN ENERGY**” will measure the temperature, humidity, air quality, and the light intensity level of the living room using various sensors. The data from the sensors is sent to the server through wireless mode. The collected data are then monitored on the webtool based on the data received to the server on the time. For the user convenience the data is monitored on the mobile app which is developed by Virtuino Software. If any changes are occurred in the indoor environment, the alert is given to the user from mobile app.

The Temperature and Humidity is measured by the DHT11 sensor and the values are collected in Celsius and percentage format. The changes of the Temperature and Humidity will not make the householder stay in comfort, so the temperature is measured and monitored continuously. If the temperature exceeds the range 29°C or lowers the range 18°C, the system provides the alert message for the user.

The mixture of the gases or the alcohol in the room will not make the user breathe comfortably. The MQ135 gas sensor will monitor the air quality level in the home. If any changes occur in the level, the windows, which connect to the servo motors, will open automatically. The LDR sensor is used to measure the intensity level of the light inside the home. If the darkness fills the room then the light which is connected to the microcontroller will automatically switch ON and if the intensity level is low then the lights get switched OFF automatically.

The data collected from the sensor will be routed to the cloud server through the Wi-Fi module (ESP8266 Wi-Fi module) which is connected to the microcontroller. The module is connected to the standard Wi-Fi at the user home. The data is then visualized in the webtool (Thingspeak) based on the time and the data that arrive in the server. Every sensor data will be visualized separately for further evaluation.

Most of the people have agreed that, they can't survive one hour of their day without their smartphone, based on that 1000's of mobile applications are developed for making the people convenient and comfortable on using it for their communication. This system is finally merged with the mobile application to provide the user to easily monitor the data level from the home.

The mobile app is developed for the user to monitor and record the levels of the changes in data and the data is compared with the threshold value for every 24 hour round the clock. The threshold values are the upholding standard of the every sensor, which is already mentioned in the condition. If any variations has been occurred in the recording data, then the mobile app will provide an alter message to the householder and other members of the home.

1.4.1. FEATURES

- Cost effective
- Data is monitored in real time
- Energy is efficiently shared for the particular devices
- Renewable Energy Source for the system
- User can monitor the data at anytime and anywhere with internet connection

System Configuration



2. SYSTEM CONFIGURATION

2.1. HARDWARE SPECIFICATION

- ❖ **Arduino UNO Atmege 328P –PU**
- ❖ **DHT11 sensor**
- ❖ **Digital LDR sensor**
- ❖ **MQ135 Air quality sensor**
- ❖ **Jumper wires and Breadboard**
- ❖ **LED bulb**
- ❖ **MG90S Metal Gear Servo Motor**
- ❖ **ESP8266 Wi – Fi module**
- ❖ **Solar panel**
- ❖ **Charge controller**
- ❖ **Inverter**
- ❖ **Smart phone**
- ❖ **Personal System**

- **RAM** **4 GB RAM**
- **Operating System** **Windows 7**
- **Operating bit** **64bit**

2.2. SOFTWARE SPECIFICATION

- **IDE** **Arduino UNO**
- **IDE Language** **Java**
- **Programming Language** **C++**
- **Arduino Version** **1.8.9**
- **Mobile Application Software** **Virtuino**

2.3. STORAGE

- **Thinkspeak Cloud Stroage**

2.4. ABOUT THE HARDWARE

2.4.1. Arduino UNO ATmega 328P-PU

The **Arduino UNO** is a microcontroller board based on the ATmega328, the design of the board is shown in the Fig.1. It is an Open-source prototyping platform for developing the pilot module of the real-time systems.



Fig.1. Arduino Uno Microcontroller

2.4.2. DHT11 sensor

DHT11 Temperature & Humidity Sensor features a temperature & humidity sensor complex with a calibrated digital signal output. By using the exclusive digital-signal-acquisition technique and temperature & humidity sensing technology, it ensures high reliability and excellent long-term stability. This sensor includes a resistive-type humidity measurement component and an NTC temperature measurement component, and connects to a high-performance 8-bit micro controller, offering excellent quality, fast response, anti-interference ability and cost-effectiveness. Table.1 shows the pin description of sensor and Fig.2 depicts the sensor board.

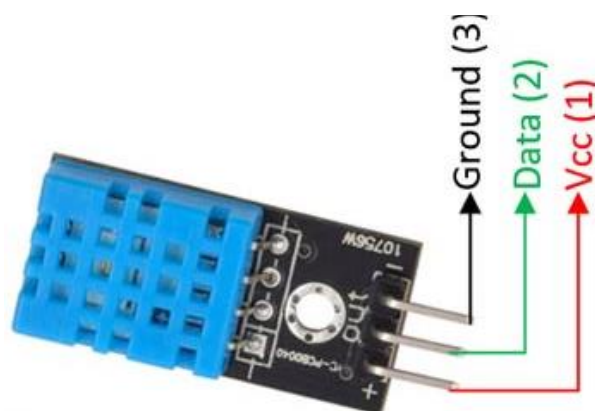

Fig.2. DHT11 sensor board

Table.1 DHT11 sensor pin description

Sl. No	Pin	Pin Description
1.	Vcc	Power supply 3.5V to 5.5V
2.	Data	Outputs both Temperature and Humidity through serial Data
3.	Ground	Connected to the ground of the circuit

2.4.3. Digital LDR sensor

The **Light Dependent Resistor** (LDR) is made from a piece of exposed semiconductor material such as cadmium sulphide that changes its electrical resistance from several thousand Ohms in the dark to only a few hundred Ohms when light falls upon it by creating hole-electron pairs in the material. The cell resistance falls with increasing light intensity. Applications include smoke detection, automatic lighting control, and batch counting and burglar alarm systems. The Fig.3 shows the pin description of the LDR sensor.

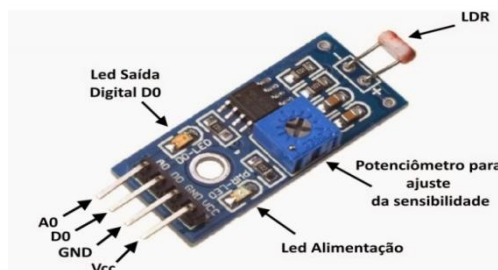

Fig.3. LDR sensor board

2.4.4. MQ135 gas sensor

The MQ135 is an air quality sensor for detecting a wide range of gases, including NH₃, NO_x, alcohol, benzene, smoke and CO₂. It has high sensitivity to Ammonia, Sulfide and Benzene steam, also sensitive to smoke and other harmful gases. The design of the sensor is shown in the Fig.4.



Fig.4. MQ135 Gas Sensor

2.4.5. MG90S Metal Gear Servo Motor

MG90S Metal Gear Mini Servo is tiny and lightweight with high output power, this tiny servo is perfect for RC Airplane, Helicopter, Quad copter or Robot. This servo has metal gear for added strength and durability. Servo can rotate approximately 180 degree (90 in each direction), and works just like the standard kinds but smaller. Any of the servo code, hardware or library to control these servos. The Fig.5 shows the servo motor, which is used for the arduino to control the devices. Good for beginners who want to make stuff move without building a motor controller with feedback & gear box, especially since it will fit in small places. It comes with a 3 horns (arms) and hardware.



Fig.5. Metal Gear Servo Motor

2.4.6. ESP8266 Wi-Fi Module

The ESP8266 Arduino compatible module is a low-cost Wi-Fi chip with **full TCP/IP capability**, and the amazing thing is that this little board has a **MCU (Micro Controller Unit) integrated** which gives the possibility to **control I/O digital pins** via simple and almost pseudo-code like programming language. This device is produced by Shanghai-based Chinese manufacturer, **Espressif Systems**. The design of the module is shown in the Fig.6.

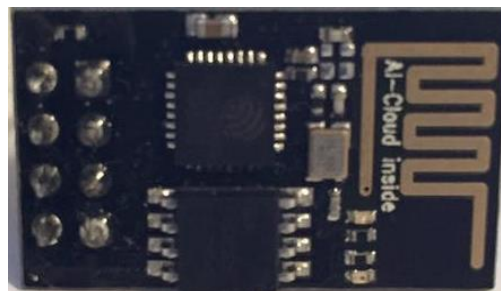

Fig.6. ESP8266 Wi-Fi Module

2.4.7. Solar Panel

Photovoltaic solar panels absorb sunlight as a source of energy to generate electricity. A photovoltaic (PV) module is a packaged, connected assembly of typically 6x10 photovoltaic solar cells. Photovoltaic modules constitute the photovoltaic array of a photovoltaic system that generates and supplies solar electricity in commercial and residential applications.

A single solar module can produce only a limited amount of power, most installations contain multiple modules. A photovoltaic system typically includes an array of photovoltaic modules, an inverter, and a battery pack for storage, interconnection wiring, and optionally a solar tracking mechanism. Every module is rated by its DC output power under standard test conditions (STC), and typically ranges from 100 to 365 Watts (W).

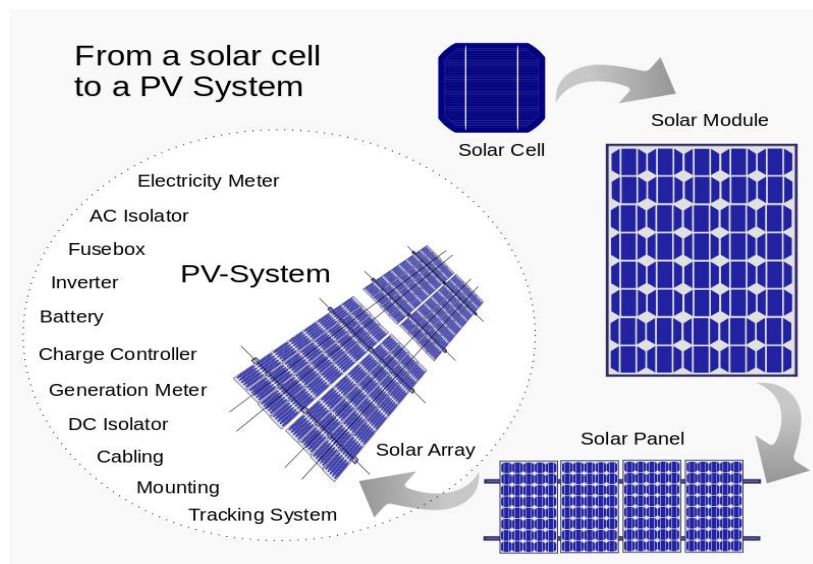

Fig.7. Solar panel development cycle

Advantages of Solar Panels

1. Solar power is pollution free and causes no greenhouse gases to be emitted after installation
2. Return on investment unlike paying for utility bills
3. Virtually no maintenance as solar panels last over **30 years**
4. Ability to live grid free if all power generated provides enough for the home / building
5. Use batteries to store extra power for use at night
6. Safer than traditional electric current

Type Solar Panels

- Mono-crystalline
- Thin-Film Solar Panels
- Polycrystalline

1. Mono- Crystalline Silicon Panels

Solar cells made of mono-crystalline silicon (mono-Si), also called single-crystalline silicon (single-crystal-Si), and are quite easily recognizable by an external even coloring and uniform look, indicating high-purity silicon. Mono-crystalline solar cells are made out of silicon ingots, which are cylindrical in shape. To optimize performance and lower costs of a single mono-crystalline solar cell, four sides are cut out of the cylindrical ingots to make silicon wafers. Fig.8 spectacles the mono crystalline solar panel array connected to produce the energy.

2. Thin-Film Solar Panels

Depositing one or several thin layers of photovoltaic material onto a substrate is the basic gist of how thin-film solar cells are manufactured. They are also known as thin-film photovoltaic cells (TFPV). The different types of thin-film solar cells can be categorized by which photovoltaic material is deposited onto the substrate:



Fig.8. Mono Crystalline Solar panel



Fig.10. Thin-film Solar panel

3. Polycrystalline Silicon Solar Panel

The first solar panels based on polycrystalline silicon, which also is known as polysilicon (p-Si) and multi-crystalline silicon (mc-Si). Unlike mono-crystalline-based solar panels, polycrystalline solar panels do not require the Czochralski process. Raw silicon is melted and poured into a square mold, which is cooled and cut into perfectly square wafers. The Fig.9 shows the polycrystalline solar panel array connected to produce the energy. The poly-crystalline solar panel is used in this project, for providing the electricity to the smart home. Comparing to the other panels it is low cost and best material for generating the solar energy.



Fig.9. Poly-Crystalline Solar panel

The average solar panel dimensions are around 165cm (height) x 100cm (width) x 4cm (depth) for residential installations, although sizes do vary slightly between solar panel manufacturers. A solar cell - also known as a photovoltaic (PV) cell - generates electricity when it's exposed to light. Individual solar cells are small and powerless on their own, which is why a large number of them are needed in each solar panel to generate enough electricity for the home. A solar cell is usually about 15cm (height) x 15cm (width). A residential solar panel is typically made up of 60 solar cells.

A solar panel system simply refers to how many solar panels need to install on the top of the roof. A single solar panel typically has a power output of between 250 watts and 350 watts. However, most of the home appliances will need kilowatts (kW) of power to work and it therefore needs several solar panels to meet the energy requirement for the home.

Solar panel systems sizes are measured in kW. Residential solar panel systems typically range in size from 1kW up to 4kW. A solar panel system bigger than this will probably be too large (and heavy) for the roof, and generate far too much electricity than is needed.

2.4.8. Charge controller

A charge controller, charge regulator or battery regulator limits the rate at which electric current is added to or drawn from electric batteries. It prevents overcharging and may protect against overvoltage, which can reduce battery performance or lifespan, and may pose a safety risk. It may also prevent completely draining ("deep discharging") a battery, or perform controlled discharges, depending on the battery technology, to protect battery life. The terms "charge controller" or "charge regulator" may refer to either a stand-alone device, or to control circuitry integrated within a battery pack, battery-powered device, or battery charger.



Fig.11. Charge controller

Features of Solar Charge Controller:

- Protects the battery (12V) from over charging
- Reduces system maintenance and increases battery lifetime
- Auto charged indication
- Reliability is high
- 10amp to 40amp of charging current
- It protects the appliances from over voltage

2.4.9. Battery

Battery storage is the next big thing in renewable energy. Solar power provides disruptive when utilizing the power directly to the home appliances; now batteries and inverters that can let homeowners avoid peak, high-cost energy costs or cut the utility cord completely are in position to be the next disruptive technology. It required to access energy when solar panels are not generating enough electricity to power household. Size varies according to owner's needs and preferences. Fig.12 displays the battery used for collecting and storing the solar energy.



Fig.12. Solar Battery

2.4.10. Inverter

A solar inverter or PV inverter is a type of electrical converter which converts the variable direct current (DC) output of a photovoltaic (PV) solar panel into a utility frequency alternating current (AC) that can be fed into a commercial electrical grid or used by a local, off-grid electrical network. It is a critical balance of system (BOS)–component in a photovoltaic system, allowing the use of ordinary AC-powered equipment.

Solar power inverters have special functions adapted for use with photovoltaic arrays, including maximum power point tracking and anti-islanding protection. Fig.13 shows the inverter used for converting the DC to AC from the battery.



Fig.13. Inverter

2.5. ABOUT THE SOFTWARE

2.5.1. Arduino IDE

The open-source Arduino Software (IDE) makes it easy to write code and upload it to the board. It runs on Windows, Mac OS X, and Linux. The environment is developed in Java and Processing other open-source software.

Features of the Arduino Software

1. Multi-Platform Application

Arduino IDE works on the three most popular operating systems: Windows, Mac OS, and Linux. Aside from that, the application is also accessible from the cloud. These options provide programmers with the choice of creating and saving their sketches on the cloud or building their programs locally and upload it directly to the board.

2. Board Management

Arduino IDE comes with a board management module, where the users can select at any moment the board that is to be worked. During changes, it can be easily carried out by choosing dropdown menu. Modifying their selection also automatically updates the PORT info with the data they need in relation to the new board.

3. Straightforward Sketching

With Arduino IDE, users can create programs called sketches that are built with a text editor. The process is a straightforward one though it has several bells and whistles that make the experience more interactive.

4. Project Documentation

Arduino IDE offers programmers the option to document their projects. This function allows them to keep track of their advancements and changes made every time. Apart from that, documentations allow other people to easily employ the sketches to their own boards.

5. Simple Sketch Sharing

Aside from saving and archiving sketches and uploading them to the board, Arduino IDE is also capable of sharing sketches (available only on the cloud version). Each sketch is given its own unique URL that users can share with their colleagues and fellow Arduino hobbyists. The recipient then has access to the code; they can save it in the cloud sketchbook or download it for their own use.

6. Vast Library

Arduino IDE has more than 700 libraries integrated. These were written and shared by members of the Arduino community that other users can utilize for their own projects without having to install anything. This enables programmers to add a different dimension to their sketches.

7. Third-Party Hardware Support

While Arduino IDE is designed specifically for Arduino boards, it also supports connections with third-party hardware. This makes the use of the application more extensive rather than limited to proprietary boards.

2.5.2. Virtuino Mobile App

Virtuino is an Android app for monitoring sensors or control electrical devices via Bluetooth, local Wi-Fi or Internet. It only contains 54 MB storage in the mobile. The app can access the Bluetooth, Network connection, Wi-Fi and the storage of the mobile, for the controlling the devices in the home or other area.

2.6. ABOUT THE CLOUD

2.6.1. Thingspeak Server

ThingSpeak is an Internet of Things (IoT) platform that collects and store sensor data in the cloud and develops IoT applications. It will provide one year free access for the first time for the account and may be extended using payment. It has integrated support from the numerical computing software MATLAB from MathWorks, allowing ThingSpeak users to analyze and visualize uploaded data using Matlab without requiring the purchase of a Matlab license from Mathworks.

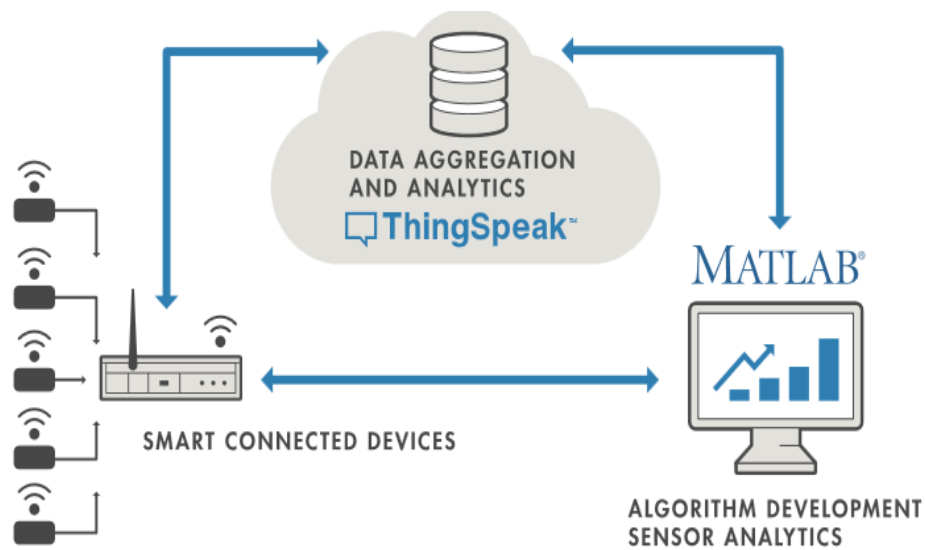

Fig.14. Smart devices connected to the Thingspeak

The smart devices are connected to the edge of the network. These devices collect data and include things like wearable devices, wireless temperatures sensors, heart rate monitors, and hydraulic pressure sensors, and machines on the factory floor. In the middle, the system have the cloud where data from many sources is aggregated and analyzed in real time, often by an IoT analytics platform designed for this purpose. The right side of the diagram depicts the algorithm development associated with the IoT application. Here an engineer or data scientist tries to gain insight into the collected data by performing historical analysis on the data. In this case, the data is pulled from the IoT platform into a desktop software environment to enable the engineer or scientist to prototype algorithms that may eventually execute in the cloud or on the smart device.

ThingSpeak Key Features

ThingSpeak allows you to aggregate, visualize and analyze live data streams in the cloud. Some of the key capabilities of ThingSpeak include the ability to:

- ❖ Easily configure devices to send data to ThingSpeak using popular IoT protocols.
- ❖ Visualize your sensor data in real-time.
- ❖ Aggregate data on-demand from third-party sources.
- ❖ Use the power of MATLAB to make sense of your IoT data.
- ❖ Run your IoT analytics automatically based on schedules or events.
- ❖ Prototype and build IoT systems without setting up servers or developing web software.
- ❖ Automatically act on your data and communicate using third-party services like Twilio® or Twitter®.



System Study



3. SYSTEM STUDY

3.1. EXISTING SYSTEM

The existing system entitled as “Bluetooth based home automation system using cell phone”, controlling the home appliances based on the Bluetooth technology. The design is based on a standalone Arduino BT board and the home appliances are connected to the input/ output ports of this board via relays. The communication link between the cell phone and the Arduino BT board is Bluetooth wireless technology. The system is designed at a cost effective mode and scalable allows diverse devices to be controlled with minimum changes. Password protection is enforced to only permit authorized users to access the appliances at home.

This home automation system consists of two main hardware components: the cell phone and the Arduino BT board. The cell phone hosts the Python script which enables the user to access the home appliances and also the control commands for the appliances. This Python script communicates with the Arduino BT board and sets up an ad-hoc communication protocol between the two devices, which allows controlling the behavior of the Arduino BT board. The circuit connection of the arduino board, the Bluetooth module and the appliances are shown in the Fig.14

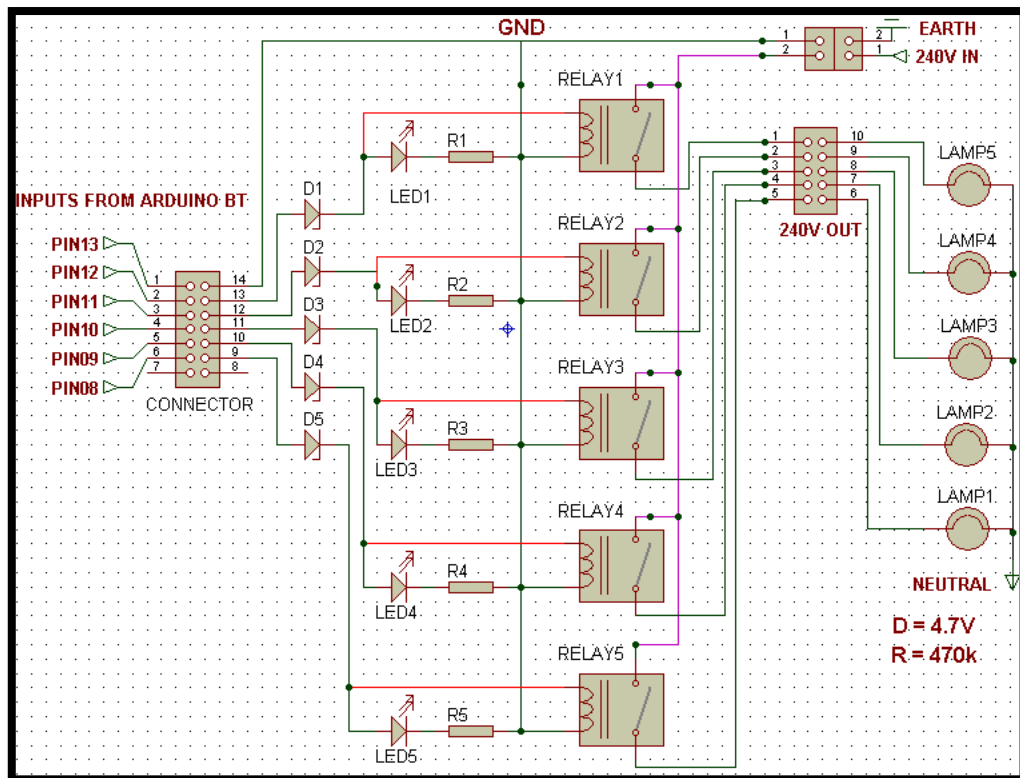

Fig.15. Circuit connection of the Bluetooth based Automation System

3.1.1. COMPONENTS USED IN THE EXISTING SYSTEM

- Arduino BT board
- Relay Board
- Bluetooth Module
- Cell phone (1100 model)
- Home Appliances

3.1.2. DRAWBACKS

- ❖ Bluetooth cannot be used for wider range in order to control and the communicate
- ❖ The software program is only used to control the devices, no automation and monitoring process is handled.
- ❖ Based on the technology development the cell phone is the 2G communication device.
- ❖ Delay in response
- ❖ Expensive
- ❖ There is no monitoring system for environmental behavior inside the home (Temperature, Humidity, etc)

3.2. PROPOSED SYSTEM

This proposed work is to create a Prototype Model based on the Solar Power to monitor the indoor environment of the home and make the home appliance to act intelligent based on automating the devices. The sensors are connected to the Arduino microcontroller, to collect the environmental factors like temperature, humidity, air quality, and the intensity value of the light reflection inside the home. The collected data are in different data format, and then the data is sent to the webtool for the real-time monitoring through the wireless technology. The Mobile App is created for the householder to monitor the environment status of the home, so that the device becomes user friendly.

Home automation is a challenging one not only to the developer but also to the consumer. Developer has to choose the component as per the customer requirement. Not all the customer demands are same and hence it has to compromise with the existing products.

There are three different sensors used to collect the environmental parameters of the house. They are,

1. DHT11 sensor – For collecting Humidity and the Temperature level.
2. MQ135 gas sensor – For collecting Air Quality level.
3. LDR sensor – For collecting the Intensity of the light.

The data is collected from the sensor and it is stored in the RAM of the Arduino, where all the hardware components are connected to the Arduino microcontroller using different types of the Jumper wires and the breadboard. The collected data is then move to the Thinkspeak server using the ESP8266 Wi-Fi module, where the URL of the storage area is mentioned in the Arduino coding and uploaded in the microcontroller.

The data is routed to the cloud server via wireless mode, from the ESP8266 Wi-Fi module which is connected to standard Wi-Fi available in the home. The module will communicate to the internet, for sending the data to the server. Then the received data will be monitored on the web tool based on using the library Mathworks, for visualizing the sensors data in the advanced graphical view.

In this technology world, almost everyone is depending on smart phones, and henceforth the design and development of the mobile applications are becoming more popular. The Home Monitoring System also uses the mobile application which is only developed for the android phones, using the Virtuino mobile software, which is directly downloaded from the Google Play Store. The Thinkspeak server will communicate with the virtuino app for making the user to handle the system very easily. The data which is stored in the database will be monitored on the mobile app by Analog Instrumental devices and the alert will provided for the user about the environmental change in the house. The mobile application will also send alert message for the house holders, whose contact numbers are added in the developed mobile application.

3.2.1. ADVANTAGES OF THE PROPOSED SYSTEM

- ✓ Cost effective
- ✓ Wider coverage of range
- ✓ Data can be monitored anywhere at any time with internet connection
- ✓ Effective Response

System Design and Methodology

4. SYSTEM DESIGN AND METHODOLOGY

This system is a prototype model of the proposed work, Solar Decathlon Africa project that was undertaken by the team members in Morocco. Considering the needs and the involvement of the technologies for the house, the team from the India had proposed the model for monitoring the home, for making the user to live comfort and convenient. The design of the system is shown in the Fig.16.

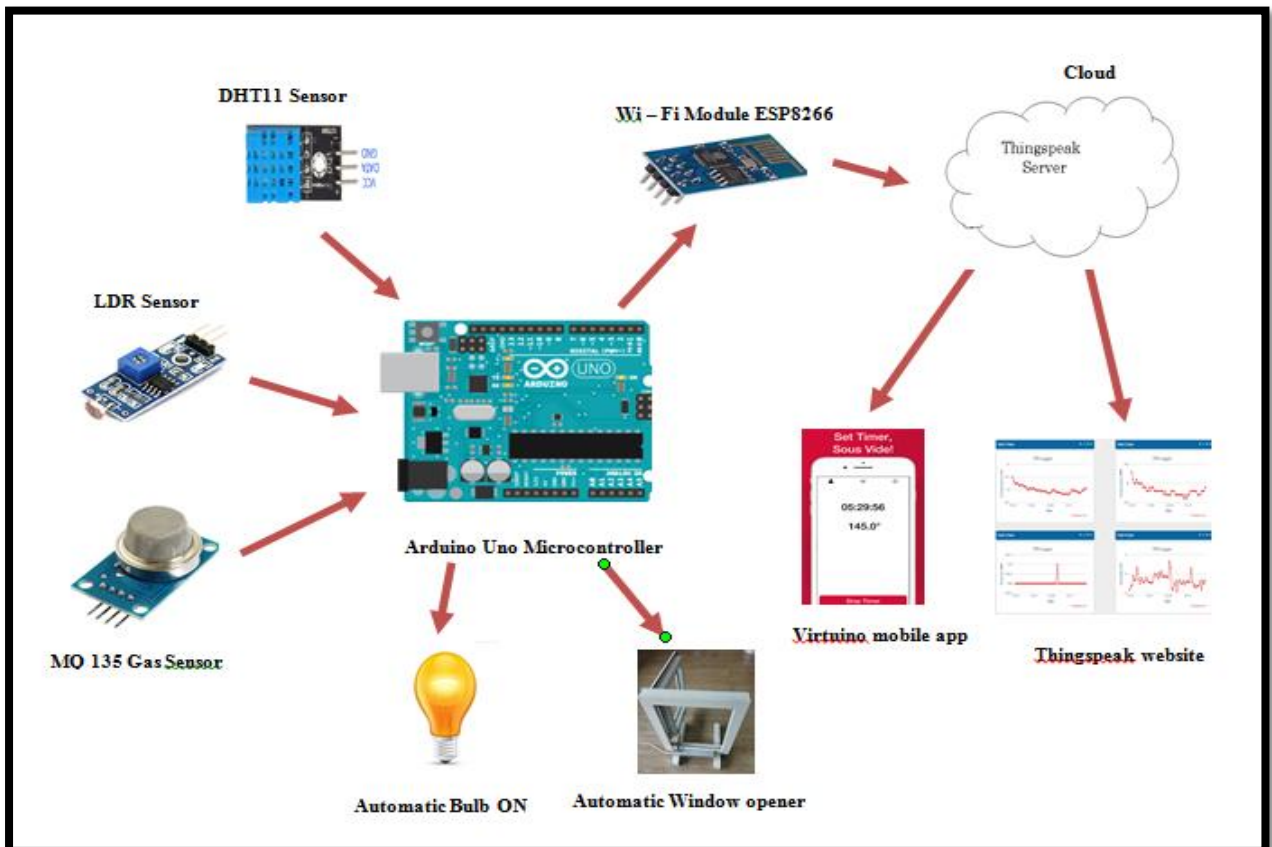

Fig.16. The system design of proposed model

The 3 different sensor, MQ135 gas sensor, DHT11 sensor and LDR sensor are connected to the arduino, for collecting the values of the room. The Light and the Servo motor are integrated with the microcontroller to perform the necessary action based on the changes occurred in the environmental factor. The ESP8266 Wi-Fi module is attached with the microcontroller to route the sensor data to the thingspeak server. Then the mobile application is developed to monitor the data of the environmental changes inside the home.

4.1. INPUT DESIGN

The input is routed to system in two different ways, they are,

1. Sensor Data
2. Server Data

4.1.1. Sensor Data

The data is collected from the different sensors, which are channeled to the arduino microcontroller and finally saved in RAM memory. The DHT11 sensor will give the temperature and the humidity level spread inside the room. Temperature is measured in Celsius and the Humidity in .rh (percentage). The MQ135 sensor will measure the quality of the air inside the room. Measure of the data will be displayed in ppm (part per meter). The LDR will measure the intensity level of the light inside the room. The format of the data is .lux (luminous) for the light intensity.

4.1.2. Server Data

The server data is the collection of different sensors values, that is collected by arduino microcontroller and it is channeled to the cloud storage by using the ESP8266 Wi-Fi module which is attached with the system, to direct the values via wireless mode. The data is separately stored in the cloud by using the table fields. This system has five fields for stowing the sensor values, they are time and date, temperature, humidity, LDR, air quality. Each value saved based on corresponding time of the data collected. The visualization is exhibited in the form of the value based on the time using the server data.

The following code is coded in the microcontroller to channel the data to the server via wireless TCP protocol,

```
GET/update?key=9XAZCSY8EHJVM TA8&field1="+A+"&field2="+L+"&field3="+T+  
"&field4="+H+"|r|n.
```

The server data is also monitored in the mobile application for the data significance and the alert process. Every analog instrument will maintain the threshold value of every sensor. If any variation occurs in the value the alert message will be given to the householder and other family members in the home.

4.2. OUTPUT DESIGN

The output design of the system is to execute the tasks performed by the hardware devices or appliances that are connected with the Arduino microcontroller. Every sensor values are collected and displayed in the serial monitor. The data monitoring is visualized in the webtool and the Mobile Application, which developed for the user to monitor the home anywhere at any time.

The two automation processes designed in this system are implemented by connecting the hardware devices to the microcontroller. If any variation occurs in the factors of environment, these processes will execute in different perspective.

1. The window opener is executed, when the quality of the air is bad, based on the variation of the air is supervised by the MQ135 gas sensor.
2. The light is switch ON automatically, when the intensity level of the light inside the room gets high, which is monitored by using the LDR sensor.

4.3.MODULE DESCRIPTION

This system completely separated and developed based on the modules they are, list in below,

4.3.1. MODULES

1. Hardware connection
 - 1) Solar panel Installation
 - 2) Temperature and Humidity Monitoring
 - 3) Automatic Light ON/OFF using LDR
 - 4) Automatic Window Opener based on Air Quality
 - 5) ESP8266 Wi-Fi module
2. Arduino Based Sensor Data Collection
3. Data Visualization
4. Mobile Application Development

4.3.2. HARDWARE CONNECTION

The hardware connection of the system is divided into 5 parts; they are given below,

4.3.2.1. Solar Panel Installation

The Solar panel is a collection of the silicon crystals covered inside the mirror to make an array formatted panel sheet, for collecting the energy. Panel will produce the DC (Direct Current) that is not suitable for providing to the home appliances, it will only perform when providing the AC (Alternative Current). The conversion of the DC from the Solar panel to AC is essential. The Inverter is an external device which is used to convert the DC to AC that is used for the installation of the solar panel to the home.

But the solar panel will generate the energy in efficiently high voltage, when the sunlight is available, it cannot be used at the night time, is one of the major drawback of using the solar power to the housed to store the solar energy, which is not used by the appliances at the day time. Then the battery power is used at the night time for the house convention.

The battery can only store DC; the solar panel produces the DC and the battery is directly connected to the solar panel for collecting the energy. Again the battery connection must be given to the inverter to convert the DC to AC for the home appliance.

For providing the Solar Power to the house usage, Charger controller is used to cut off the power between the panel and the battery. The energy from the panel is directly is at day time, then the battery power is used at the night time. So the Panel, Battery and the Inverter is connected to the charger controller.

For this prototype design, 12V Solar panel, 12V battery, 12V Charger controller and the 12 V inverter is used for producing the power from the solar panel. The solar panel, inverter and the battery is connected to the different positive and the negative end of the charger controller. The circuit design of the connection is shown in the Appendix → Fig 9.1.

4.3.2.2. Temperature and Humidity Monitoring

It is important to monitor the Temperature and the Humidity level inside the home. Unbalance level of the temperature will cause the skin problems, chickenpox and it make the house member to stay out from the home, same as for the humidity level.

The temperature and the humidity is measured using DHT11 sensor, the temperature is measured in Celsius format and the humidity is measured in rh (percentage). The DHT11 has three pins for connecting the sensor to the Arduino microcontroller. Vcc is the power supply of the sensor; it is connected to the 5v power of the microcontroller. The GND is the ground connection of the sensor; it is connected to the any GND pin of the microcontroller. Data pin will provide the data of the temperature and the humidity level of the particular area; it is connected to the Digital Pin 4 of the microcontroller. So that the data can be collected from the pin 4, none other connection may not be connected to the pin 4. The circuit diagram of the DHT11 sensor connection is shown in the Appendix → Fig 9.2. The hardware connection of the module is shown in the Appendix → Fig 9.7.

4.3.2.3. Automatic Light ON/OFF using LDR sensor

The LDR is a Light Density Resistance, which is used to measure the intensity of the light reflection inside the home. Normally it was used in the Automatic Street light using the solar power, to switch ON/OFF the light automatically. As same, the application was used in this system for switch ON/OFF the light automatically, when darkness fills the home.

The LDR has three pins and is applicable for connecting the sensor to the Arduino microcontroller. Vcc is the power supply of the sensor; it is connected to the 5v power of the microcontroller. The GND is the ground connection of the sensor; it is connected to any GND pin of the microcontroller. Data pin will provide the data of the intensity level of the light in the particular area; it is connected to the Analog pin 0 of the microcontroller. So that the data can be collected from the pin A0, none other connection may not be connected to the A0. The intensity is displayed in lux format. The circuit diagram of the LDR sensor connection with the Arduino board is shown in the Appendix → Fig 9.3. The hardware connection of the module is shown in the Appendix → Fig 9.8.

The ON/OFF of the LED bulb is the output of the system, The long end of the LED is connected to the Digital pin 10 of the board and the short end is connected to the Resistor for balancing the brightness of the light and it is connected to the GND pin of the board.

4.3.2.4. Automatic Window Opener based on the Air Quality

Indoor air quality is the most important factor when it comes to the breathability of the air at home. If the range drops below a certain level, the user or the house member's bound to suffer from respiratory problems. The real concern here is that most homeowners attribute poor air quality to pollen, dust, and other contaminants.

The MQ135 sensor will provide the air quality level inside the home. The sensor has four pins, for connecting the sensor to the Arduino microcontroller. Vcc is the power supply of the sensor; it is connected to the 5v power of the microcontroller. The GND is the ground connection of the sensor; it is connected to the any GND pin of the microcontroller. Data pin (D0) will provide the digital data of the air quality level in the particular area and the Data pin2 (A0) will give the analog data of the air quality level of the home. Mostly the analog pin is used for collecting the data; it is connected to the Analog pin 1 of the microcontroller. So that the data can be collected from the pin A1, none other connection may not be connected to the A1.

The air quality level is displayed in ppm (part per meter) format. The circuit diagram of the MQ135 gas sensor connection with the Arduino board is shown in the Appendix → Fig 9.4. The hardware connection of the module is shown in the Appendix → Fig 9.9.

The Window opener is the output for the system, the servo motor is used for opening the windows. There are 3 connections that are done on the motor for performing the action, yellow pin is connected to the digital pin 8 of the board and the other two pins are connected to the power supply and the GND pin of the board.

4.3.2.5. ESP8266 Wi-Fi module

The Wi-Fi module is used for communicating the Arduino to the other devices. If it is connected to the internet then the communication becomes successful. The special AT commands are used for communicating with the Wi-Fi module. The Default baud rate of the ESP8266 is 19200, the programmer need to change the baud rate of the module by programming into the microcontroller for communicating. The module has 8 pins; the pin-out of the module is shown in the Fig.17. The ESP8266 uses Rx and Tx for the communication, that is connected to the Tx and RX pin of the Microcontroller. The Vcc and the CH_EN pin are to be connected to the 5V power supply of the microcontroller. The GND is connected to the GND of the microcontroller. The circuit diagram is shown in the Appendix → Fig 9.5. The hardware connection of the module is shown in the Appendix → Fig 9.10.

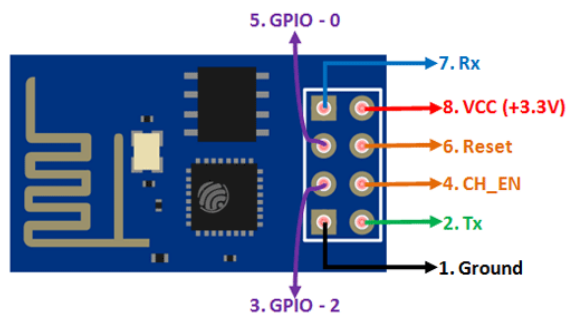

Fig .17, ESP8266 module pin diagram

4.3.3. ARDUINO AND THE SENSOR DATA

The Arduino IDE is used for programming the task for the hardware using the basic language C, So that the beginners can easily program the code for the particular function. The microcontroller will execute the task based on the sequential order, where the programmer defined by the IDE and uploaded it on the board. The complete system coding is written in the Arduino IDE, so that it is easy to develop the prototype. The DHT11 sensor and the servo motor need the separate library to be imported on the IDE for executing the task. The ESP8266 module commands are also integrated with the IDE language for the hardware communication via wireless mode. The data collection and server communication is mention in the coding.

4.3.4. DATA VISUALIZATION

The various data collected from the sensors are stored in the server, and it is visualized in the Thinkspeak web tool based on using the Mathworks library and advanced graphical tools used for charting the data in real time, based on the time and the data collected on the particular time. The Thinkspeak is an Open data platform for the Internet of Things to analysis the data with secure and privately. The programmer or the user needs to have the account on the Mathworks for getting in to the cloud storage. Then create a channel and the fields to store the sensors data in the cloud storage. After creating the fields, some of the changes need to carry on the chart.

The input level of the chart is to be change into 5, for monitor the data in every 5 seconds, to provide the real time monitoring of the data and also we can export the collected data from the server by clicking on the Data Export option in the API modification page of the webtool. The Fig.9.6 shows the Thinkspeak server data visualization area of the sensor data.

4.3.5. MOBILE APPLICATION DEVELOPMENT

The virtuino mobile app is an open source used to monitor the data from the server to the mobile application. The programmer needs to create the server on the mobile application; the Thinkspeak is the server that is used to create the space by entering the Channel ID, Read, and the Write API Key of the server in the mobile application. Update the interval at every 15 seconds in the flow chart to store the data into the server. The Analog instrument is used to monitor the sensor data and the condition for providing the alert notification for the user.

The threshold values of the every environmental factor and the alert messages to the user and the other members in the home are shown in the Table 2.

Table.2 Threshold values of the every sensor data

Sl. No.	Environmental Factor	Min	Max	Alert Message
1	Temperature	18 °C	28 °C	Temperature is Low/High
2	Humidity	30%	80%	Humidity level is not comfort for living
3	Air Quality	< 200 ppm	> 200 ppm	Air quality is bad it is not good for breath
4	Light intensity	>500 lux	>900 lux	Light is Switch ON/OFF

Based on the threshold value, the temperature level between 18° C to 28° C will make the user to stay convenient and comfort inside the home. If the values exceeds or lower the range of the maintenance level, the user gets an alert message about the current level of the temperature inside the home. Same as the temperature, the humidity range also maintained for its level. The variation in the environmental factor will monitor in the mobile application.

The light intensity value is measured in the form of luminous, if the level is high (nearly to the value 900 .lux), then the darkness of the room is also high. If the intensity level is low (less than 500 .lux), then the sunlight is spread inside the room more conveniently. Based on the measured value the LED bulb inside the room gets switch ON/OFF automatically. The change of the intensity value is informed to the user about the function of the module through the mobile application.

Maintaining the air quality level is important for the user to stay in the room or any closed area. Based on the range specified in the solar decathlon user guide, the air quality level for the solar house is, if the ppm value more than 200 is considered as bad quality of the inside the living room. The variation in the value will control the window opener to automatically open or close. The every variation of the air quality level is notified to the user and the householder through the message via the mobile application.



Results and Discussion

5. RESULTS AND DISCUSSION

5.3.RESULTS

The system is completely executed and the outputs for the every module are correctly fulfilled based on the sequence of the units specified in the module description.

The temperature and the humidity value are collected from the DHT11 sensor, which is connected to the digital pin of the arduino microcontroller. The recording values from the sensor are noticed in the serial monitor, the data is also transmitted to the thinkspeak server via the ESP8266 module. Then the visualization of the data is monitored through the webtool based on the time and the data gathered in the cloud. The mobile application that is developed for the user to easily analysis the data from the web server, for providing the real time analysis of the home environment. The collection of the data that is monitored in the mobile application is shown in the Fig.18.

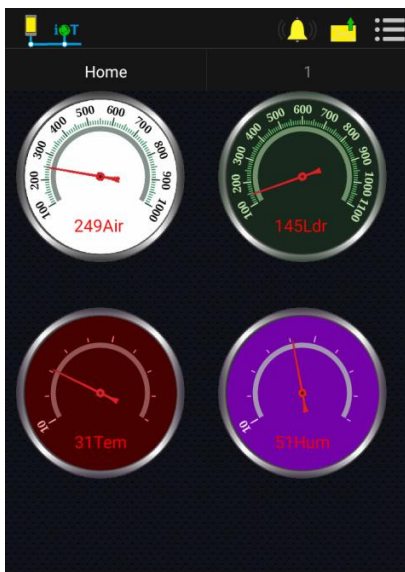

Fig 18. Data monitoring on mobile application

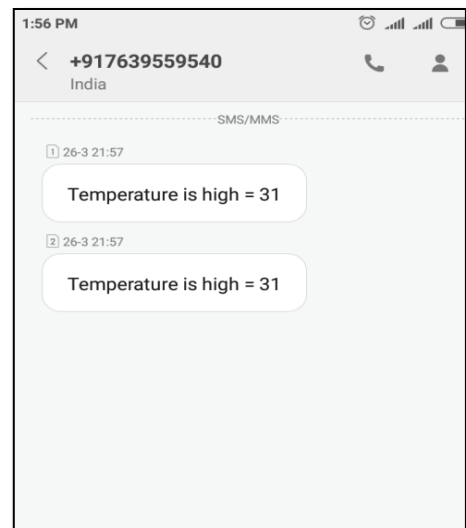

Fig 19. Alert message in the user mobile

Air quality level inside the home is collected by attaching the MQ135 gas sensor to the arduino microcontroller and the results are displayed in the serial monitor of the Arduino IDE. Then the automation process of opening the window automatically is performed based on the recorded value from the sensor. The servo motor is used to open the window that is connected to the edge of the window frame. If the sensor value is exceeds the threshold level, then the window will open in 90 degree right angel and the every variations is monitored in the mobile application.

The Fig 19 and Fig 20 shows the performance of the system when the quality of the air is bad and it is not comfort for breathing.

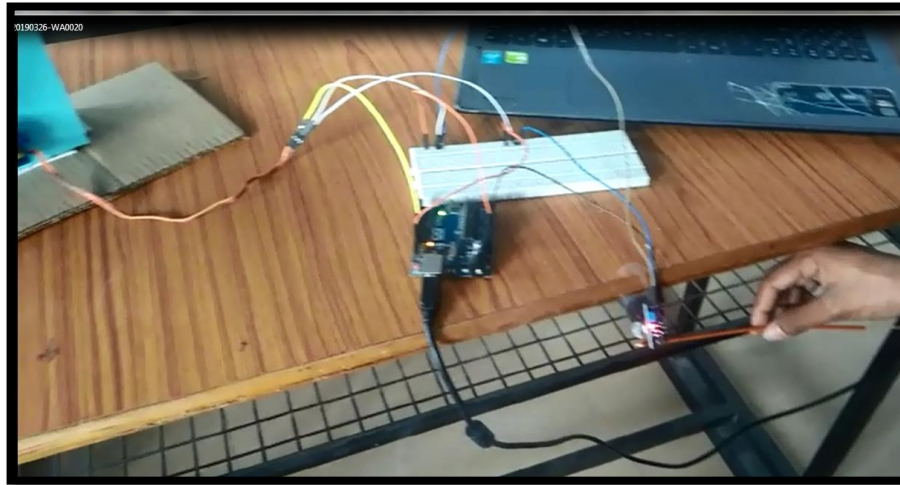

Fig 20. Sensing the bad quality of the air

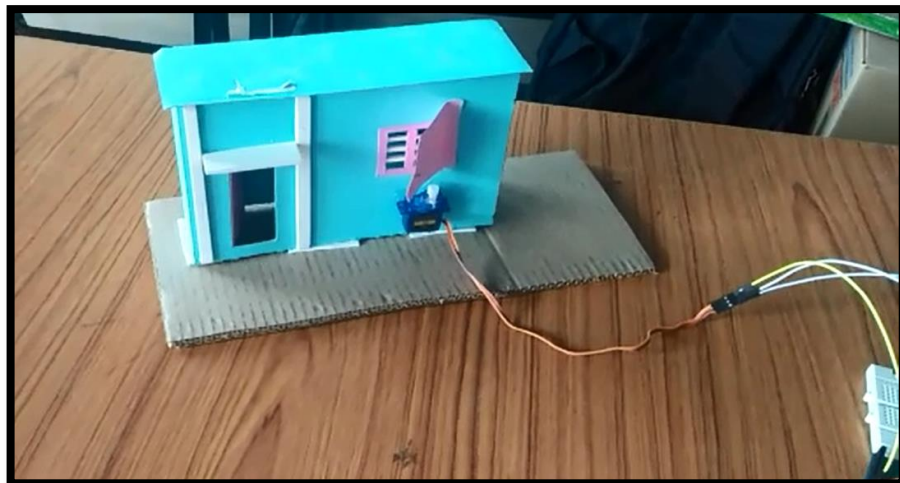

Fig 21. Window is opened automatically when the air not good

The intensity of the light is measured from the LDR sensor, which is attached with the arduino microcontroller. The automation process of switch ON/OFF the led bulb, is executed based on the variation occurs in the threshold value for the sensor reading. The Fig.21 shows the performance of automatic light ON/OFF system, when the darkness fills the room.

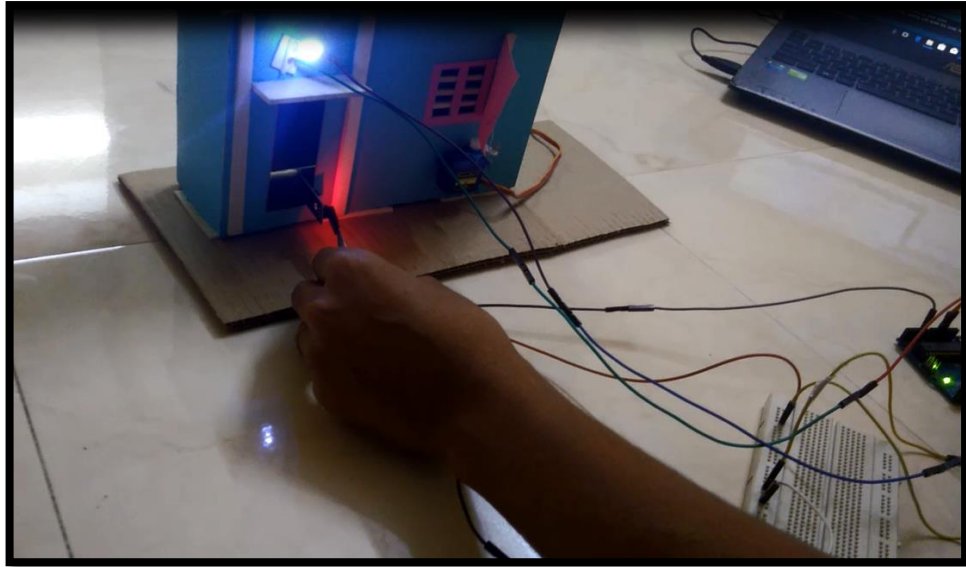

Fig 22. The LED is Switched ON automatically when the room is dark

Based on output of the modules, the sensor recorded the environment factors of the room and the values are routed to the webserver using the Wi-Fi module and the data visualization on the webtool is successfully monitored. Then the mobile application receives the sensor data from the cloud storage and the monitoring of the data through the mobile application is performed successfully. Also the alert notification to the user and the householder are ensured properly.

5.4. MODULE TESTING

The modules of the system are divided into 4 parts that are implemented and executed separately;

5.4.1. Hardware Connection

- A.** Solar panel installation is done successfully. The power is stored in the battery and also used for the hardware devices
- B.** DHT11 sensor is connected to the microcontroller, the coding for collecting the temperature and the Humidity is written and uploaded in to the microcontroller. The output is displayed in the serial monitor is shown in the Appendix → Fig 9.11.
- C.** LDR sensor and the LED is connected to the microcontroller, the coding for measure the intensity level of the light and the automation process for the LED bulb is written and uploaded in to the microcontroller. The output is displayed in the serial monitor is shown in the Appendix → Fig 9.12.
- D.** MQ135 gas sensor and the servo motor is connected to the microcontroller, the coding for collecting the air quality level and the automation process is written and uploaded in to the microcontroller. The output is displayed in the serial monitor is shown in the Appendix → Fig 9.13.
- E.** The ESP8266 Wi-Fi module is connected to the microcontroller; the coding for sending the sensor data to the cloud server is written and uploaded in to the microcontroller. The output is displayed in the serial monitor is shown in the Appendix → Fig 9.14.

5.4.2. Data Visualization

The data visualization through the webtool using the collected sensor data is monitored for the every 5 seconds. The monitored screen is shown in the Appendix → Fig 9.20, Fig 9.21, Fig 9.22 and Fig 9.23.

5.4.3. Mobile Application Development

The mobile application for monitoring the data and alerting process are developed for the user and it is monitored successfully. The mobile application screen is shown in the Appendix → Fig 9.25, Fig.9.26, and Fig 9.27.

5.5. INTEGRATION TESTING

The modules of the system are integrated and processed successfully. The Integration of the system is shown in the Appendix → Fig 9.15.

5.6. SYSTEM TESTING

The hardware execution of the automatic window opener based on the bad quality of the air is tested and it works successfully. The performance of the module is shown in Appendix → Fig 9.16 and 9.17.

The module automatic light ON/OFF using LDR is performed by connecting the LED on the arduino board. When the room is filled with dark, then the LED is switched ON automatically. If the room has the sufficient amount of the light, then the LED is switched OFF automatically. The Appendix → Fig 9.18 and Fig 9.19 will show the result of the module execution

Conclusion



6. CONCLUSION

The system is a prototype model for monitoring the Air Quality, Temperature and Humidity level of the living area for user comfort. Generating the electricity based on the green energy is a biggest advantage of the system, because the user need not bother about the power cut problems. The smart home has the capability of giving the optimum living conditions required naturally. Using different sensors installed in the home, environmental and regular appliances are operated in automatically. The renewable source of energy has been utilized in power generation for the functioning of all the smart appliances used to sustain the automated home. The sensor data is collected and the level is monitored through the web tool and the mobile app via the wireless mode. The system provides the real time analysis of the sensor data collected from the various sensors is visualized using the Mathworks library. The user can view the monitored data at anywhere, at any time at any area with the internet established. The system becomes user friendly and convenient for the householders for carrying it to the device to where ever. The data response and the automation process is properly executed based on the schedule is allotted in the microcontroller.

Scope for Future Development

7. SCOPE FOR FUTURE DEVELOPMENT

The following factors are to be considered for further enhancement towards the development of the system,

- Controlling the home devices through mobile app
- Communicating with Home Appliances through the wireless mode
- Controlling of the System must be done using the Mobile Application through Internet
- Generation of monthly report in view of the behavioral change of the environment aspects at home that occurs when the data goes beyond threshold value.



Bibliography

8. BIBLIOGRAPHY

IEEE REFERENCES

1. G.Mahalakshmi, M.Vigneshwaran; (2017) IOT Based Home Automation Using Arduino, International Journal of Engineering and Advanced Research Technology (IJEART), ISSN: 2454-9290, Volume-3, Issue-8.
2. R.Piyare, M.Tazil; (2011), BLUETOOTH BASED HOME AUTOMATION SYSTEM USING CELL PHONE, IEEE 15th International Symposium on Consumer Electronics.
3. Sheetal Prusty, (2017), Arduino Based Home Automation using Android Application, International Journal of Intelligent computing and Applied Sciences.

WEBSITE REFERENCES

- https://www.researchgate.net/publication/321874873_IOT_Based_Home_Automation_Using_Arduino
- https://www.researchgate.net/publication/231182479_Bluetooth_based_home_automation_system_using_cell_phone
- https://www.researchgate.net/publication/321767930_ARDUINO_BASED_HOME_AUTOMATION_USING_ANDROID_APPLICATION
- <https://acadpubl.eu/jsi/2018-118-16-17/articles/17/57.pdf>
- <https://www.irjet.net/archives/V4/i2/IRJET-V4I2131.pdf>
- <https://ieeexplore.ieee.org/document/7955836>
- <https://pdfs.semanticscholar.org/8ec7/255ad1d48a137c68166e1adede6d0ca1846b.pdf>
- <https://www.ijsr.net/archive/v6i5/3051709.pdf>
- <https://www.pantechsolutions.net/iot-projects/iot-based-humidity-and-temperature-monitoring-using-arduino-uno>
- <https://electronicsforu.com/electronics-projects/humidity-temperature-monitoring-using-arduino-esp8266>

- <https://circuitdigest.com/microcontroller-projects/arduino-light-sensor-using-ldr>
- <https://www.instructables.com/id/Auotmatic-Street-lights-control-using-LDR-and-Ardu>
- <https://circuitdigest.com/microcontroller-projects/iot-air-pollution-monitoring-using-arduino>

Appendix



9. APPENDIX

9.3.CIRCUIT DIAGRAM

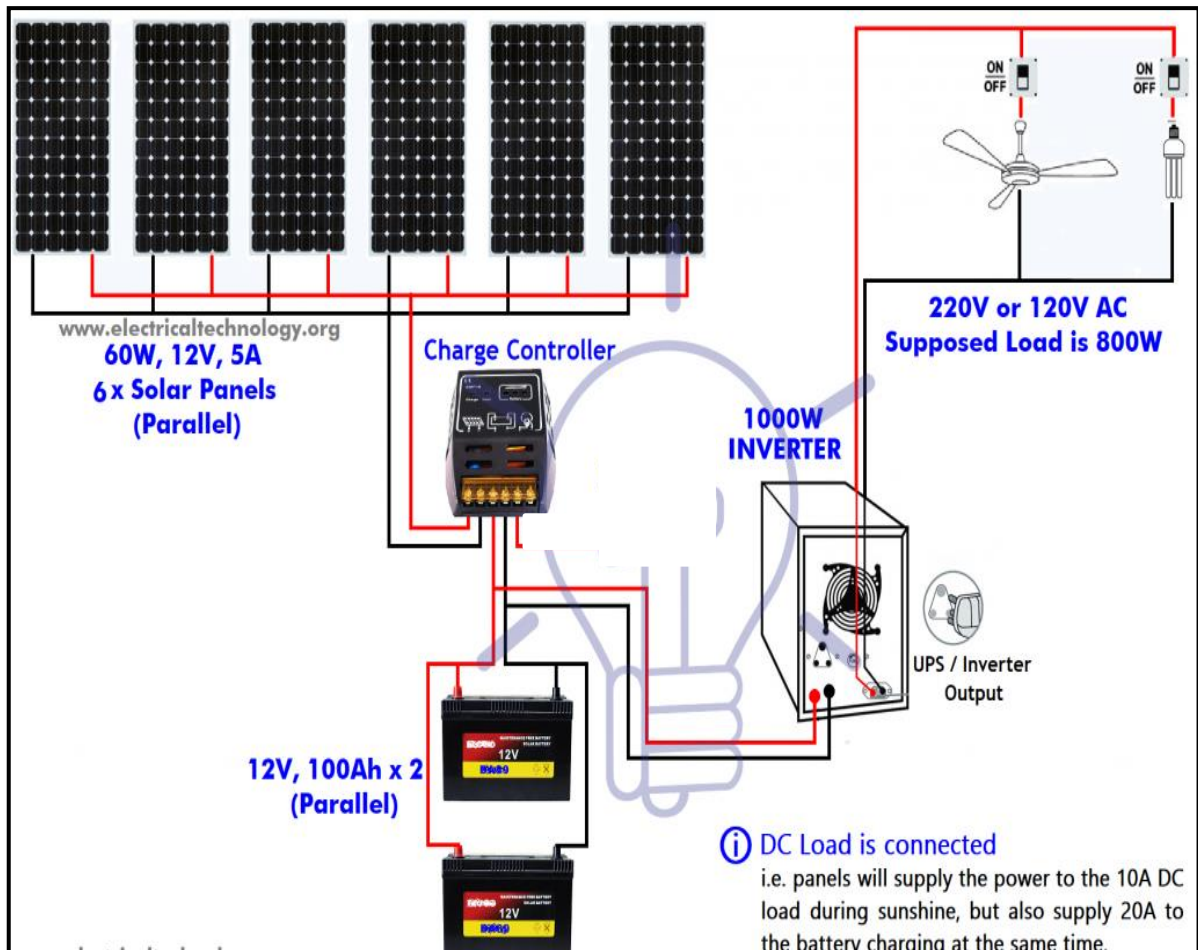

Fig.9.1. Solar Panel Installation

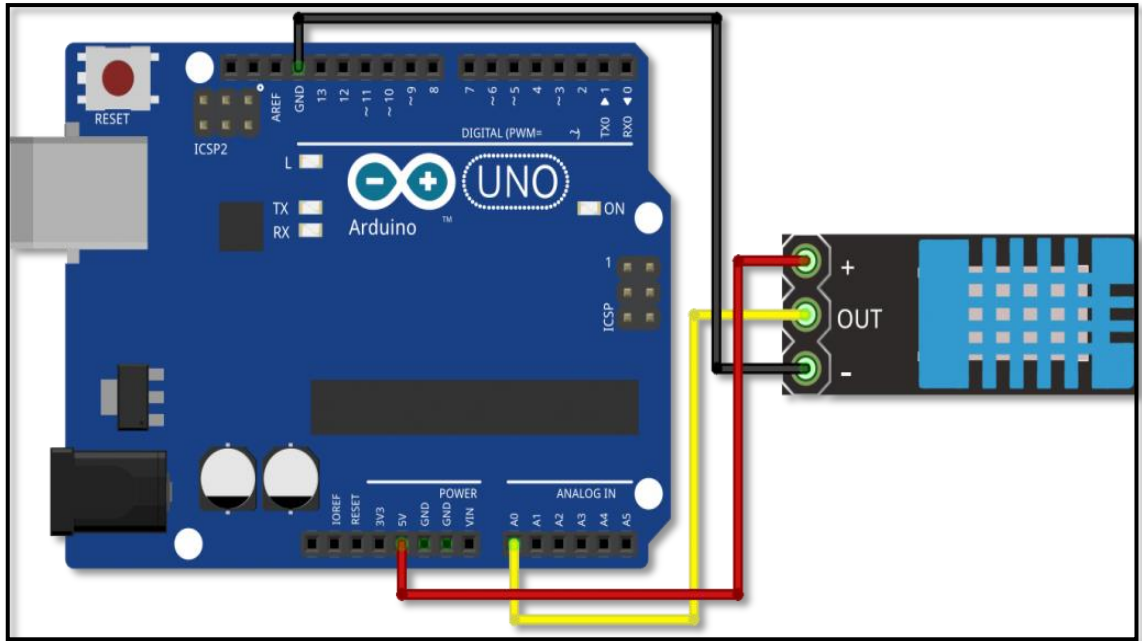

Fig 9.2. DHT11 sensor connection circuit

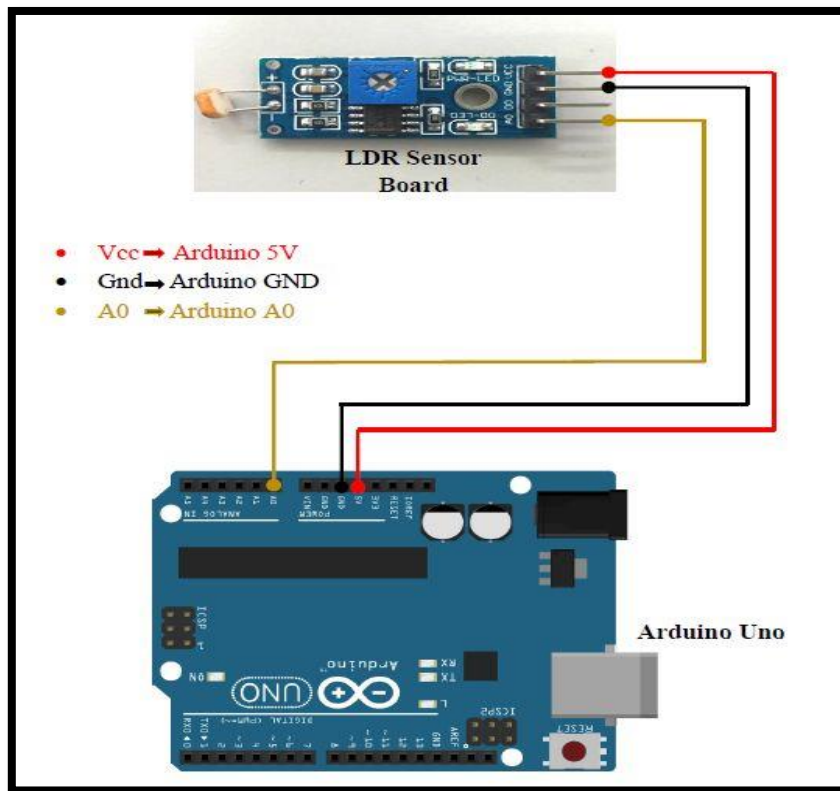

Fig 9.3. LDR sensor connection

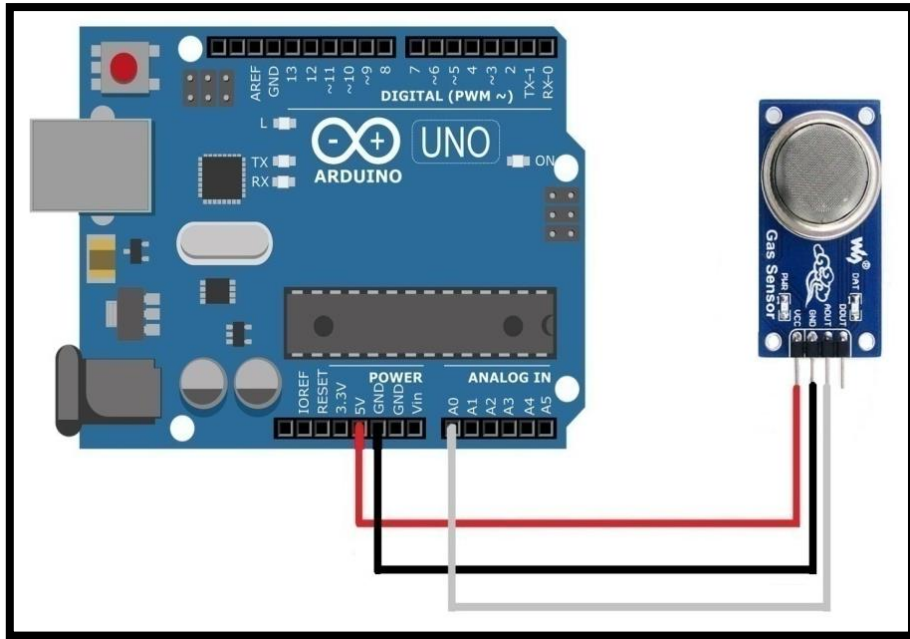

Fig 9.4. MQ135 gas sensor connection

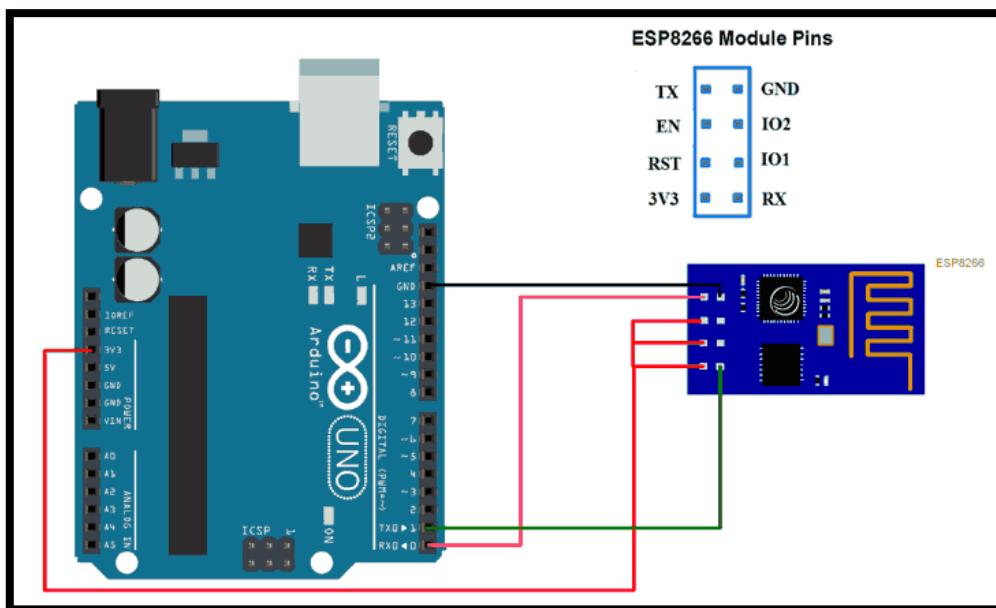

Fig 9.5. ESP8266 W-Fi module connection with Arduino

Signed in successfully.

My Channels

[New Channel](#)





Name	Created	Updated
 Solar Decathlon Project Private Public Settings Sharing API Keys Data Import / Export	2018-09-27	2019-03-26 15:45
 Test Channel Private Public Settings Sharing API Keys Data Import / Export	2018-10-05	2018-10-05 11:04
 Sensor Private Public Settings Sharing API Keys Data Import / Export	2018-11-24	2018-11-27 09:06
 New work Private Public Settings Sharing API Keys Data Import / Export	2018-11-29	2018-11-29 08:56

Fig 9.6. Data Visualization in Thinkspeak cloud

9.4. MODULE CONNECTION



Fig 9.7. DHT11 sensor connection with Arduino

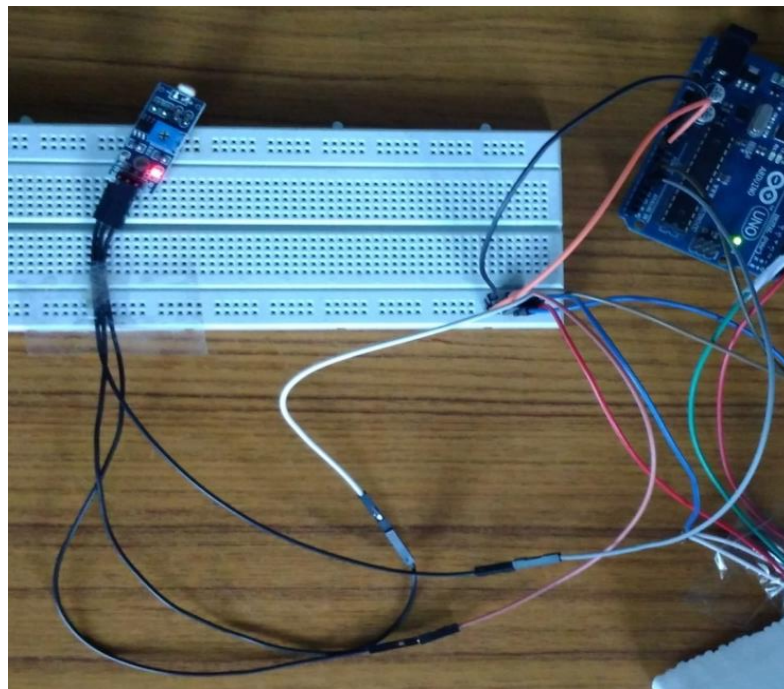

Fig 9.8. LDR sensor connection with Arduino

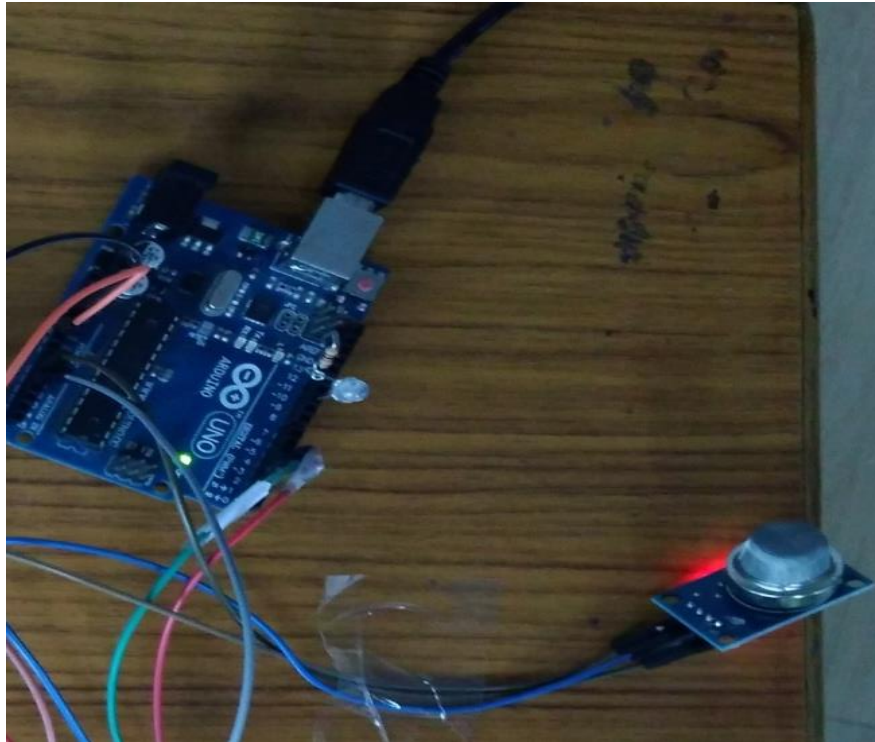

Fig 9.9. MQ135 gas sensor connection with Arduino

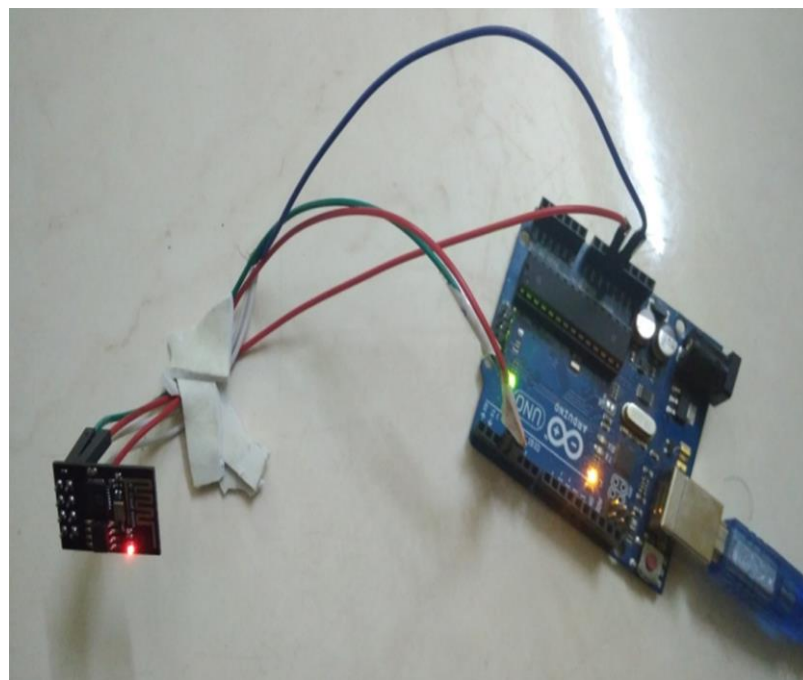
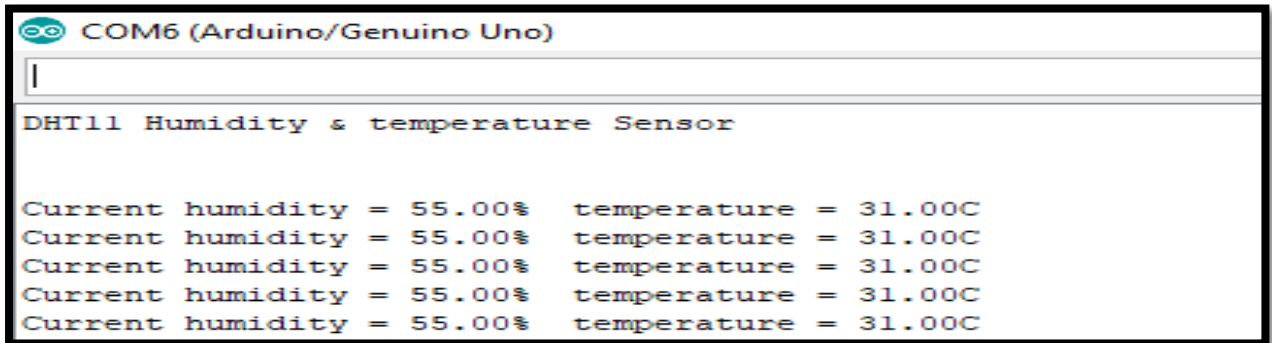

Fig 9.10. Connecting ESP8266 with arduino

9.5. MODULE TESTING RESULT



COM6 (Arduino/Genuino Uno)

```
DHT11 Humidity & temperature Sensor  
  
Current humidity = 55.00%    temperature = 31.00C  
Current humidity = 55.00%    temperature = 31.00C  
Current humidity = 55.00%    temperature = 31.00C  
Current humidity = 55.00%    temperature = 31.00C  
Current humidity = 55.00%    temperature = 31.00C
```

Fig 9.11. Serial Monitor output of the DHT11 sensor



COM6 (Arduino/Genuino Uno)

```
LDR Value  
1023  
LDR Value  
1023  
LDR Value  
1023  
LDR Value  
1023  
LDR Value  
1023
```

Fig 9.12. Serial Monitor output of the LDR sensor

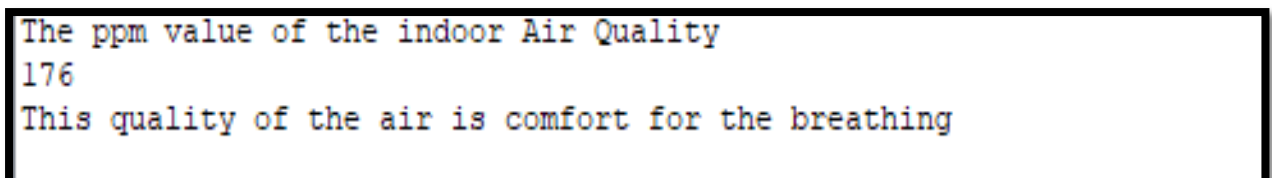

```
The ppm value of the indoor Air Quality  
176  
This quality of the air is comfort for the breathing
```

Fig 9.13. Serial Monitor output of the MQ135 gas sensor

```
AT+RST
OK
WIFI DISCONNECT
bBISRcj??*?N?qSN?I??O??tDP?P{?P??6D?t??V?? C?D?R??
Ai-Thinker Technology Co. Ltd.

ready
AT

OK
WIFI CONNECTED
AT+CWMODE=1

OK
WIFI GOT IP
AT+CWJAP="Preethi","preethi26091995"
WIFI DISCONNECT
QAT+CIFSR
+CIFSR:STAIP,"192.168.43.156"
+CIFSR:STAMAC,"68:c6:3a:c4:a9:dd"

OK
AT+CIPMUX=0

OK
```

Fig 9.14. Serial Monitor output of ESP8266 is connected to Wi-Fi

9.6. MODULE INTEGRATION RESULT

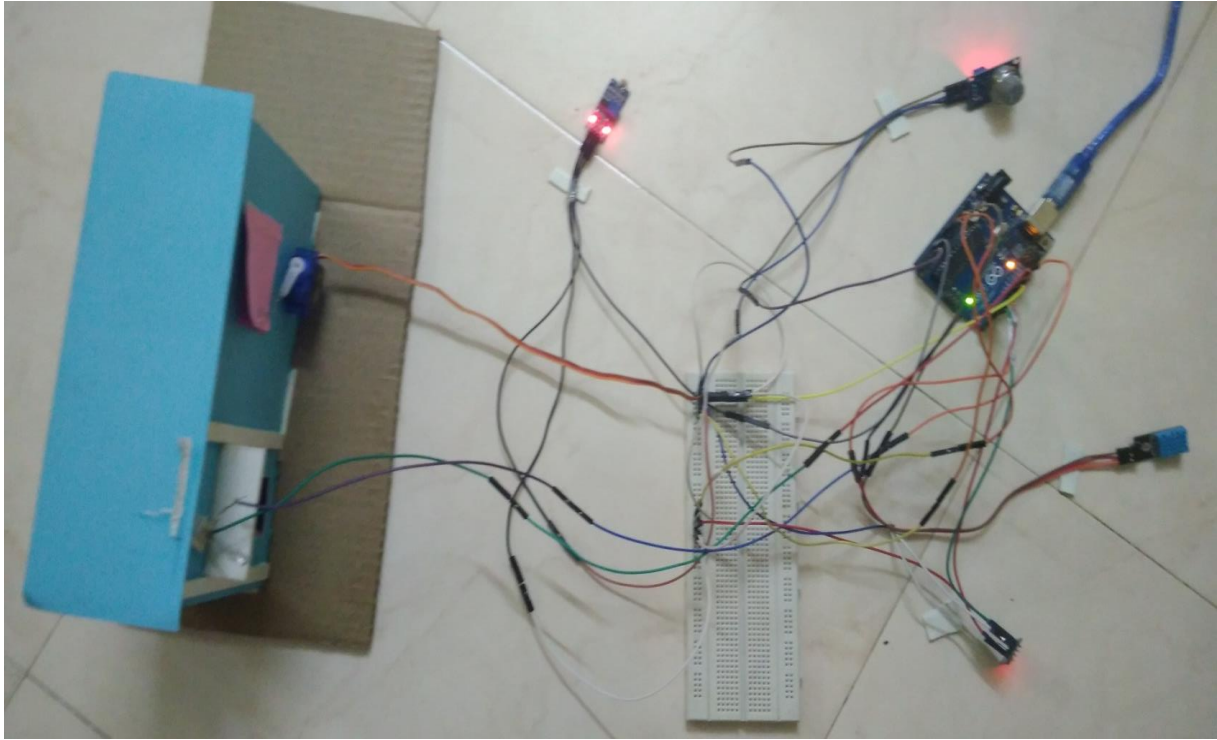

Fig 9.15. Complete integration of the Monitoring System

9.7.SYSTEM TESTING RESULT

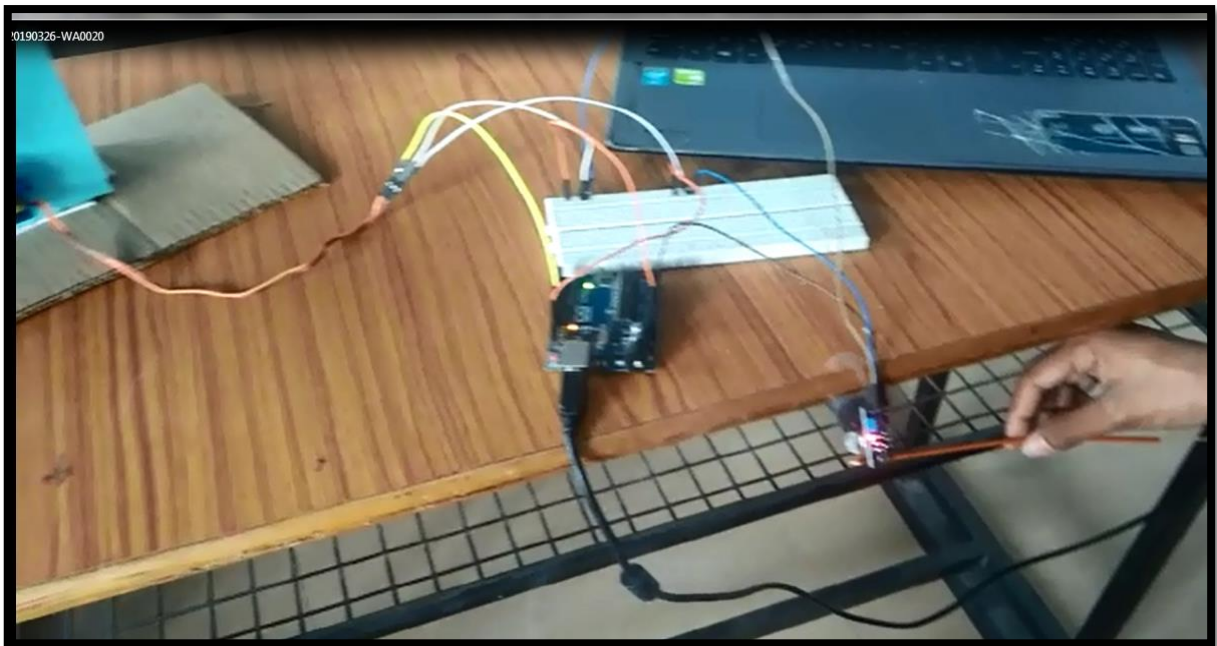

Fig 9.16. Sensing the bad quality of the air

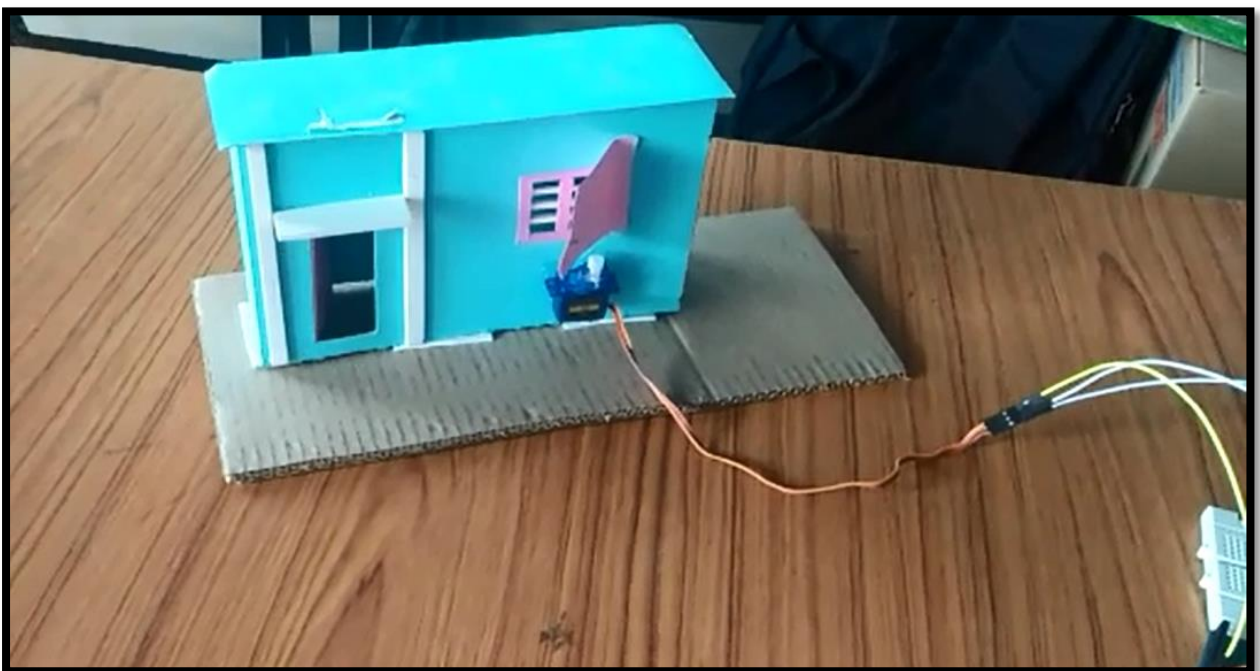

Fig 9.17. Window is opened automatically when the air not good

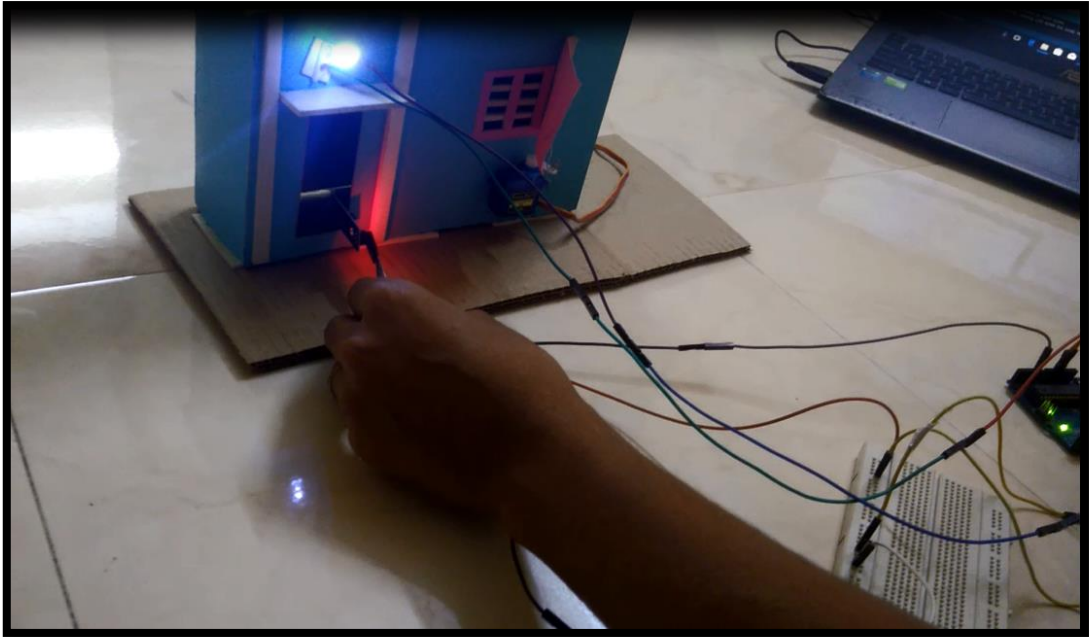

Fig 9.18. The LED is Switched ON automatically when the room is dark

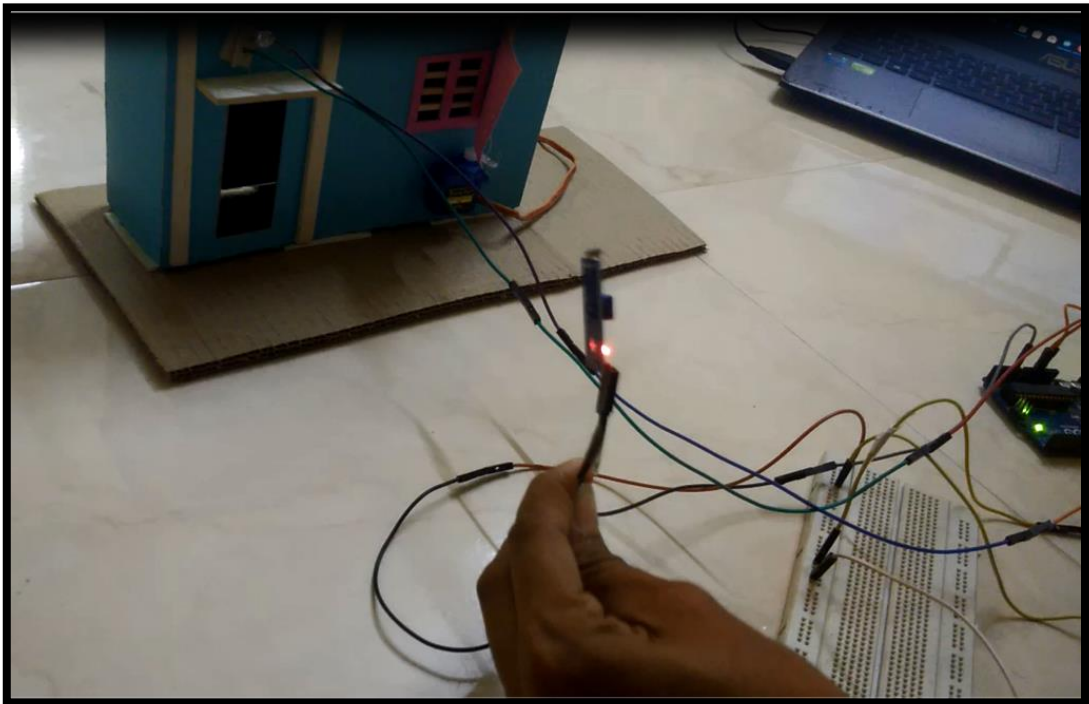

Fig 9.19. The LED is Switched OFF automatically when the room is bright

9.8.DATA VISUALIZATION

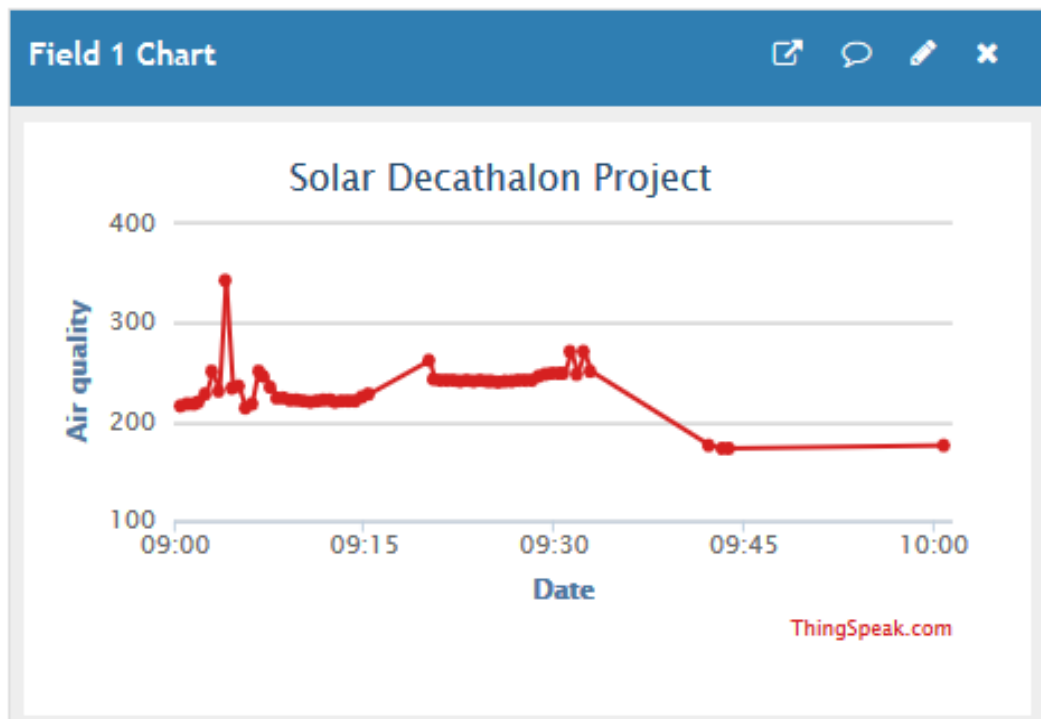

Fig 9.20. Graphical visualization of the air quality sensor data

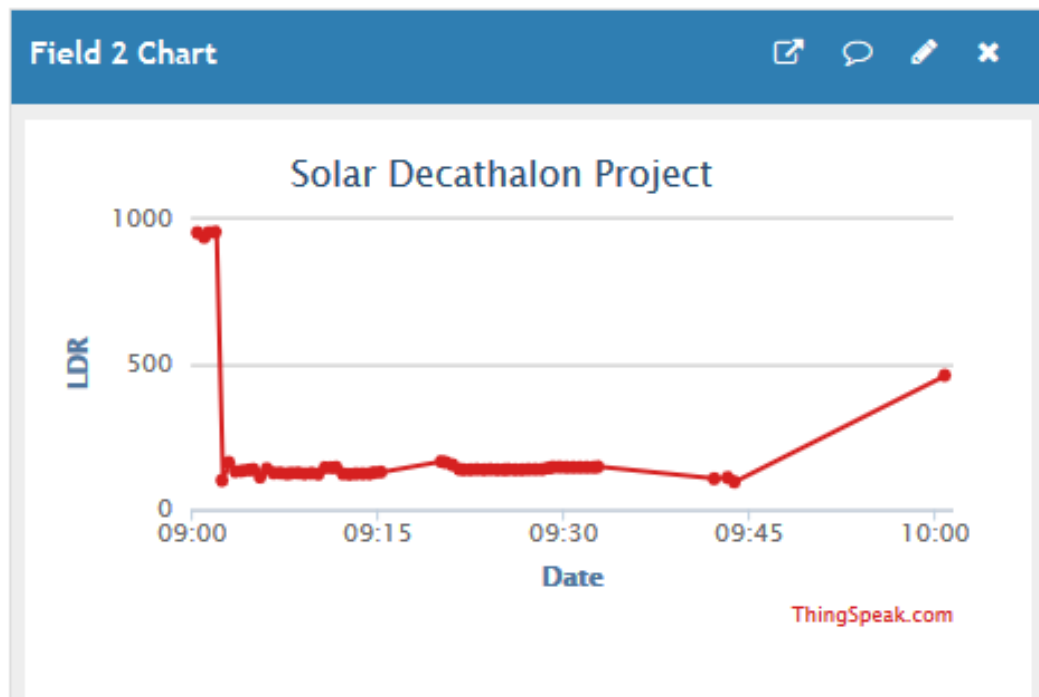

Fig 9.21. Graphical visualization of the LDR sensor data

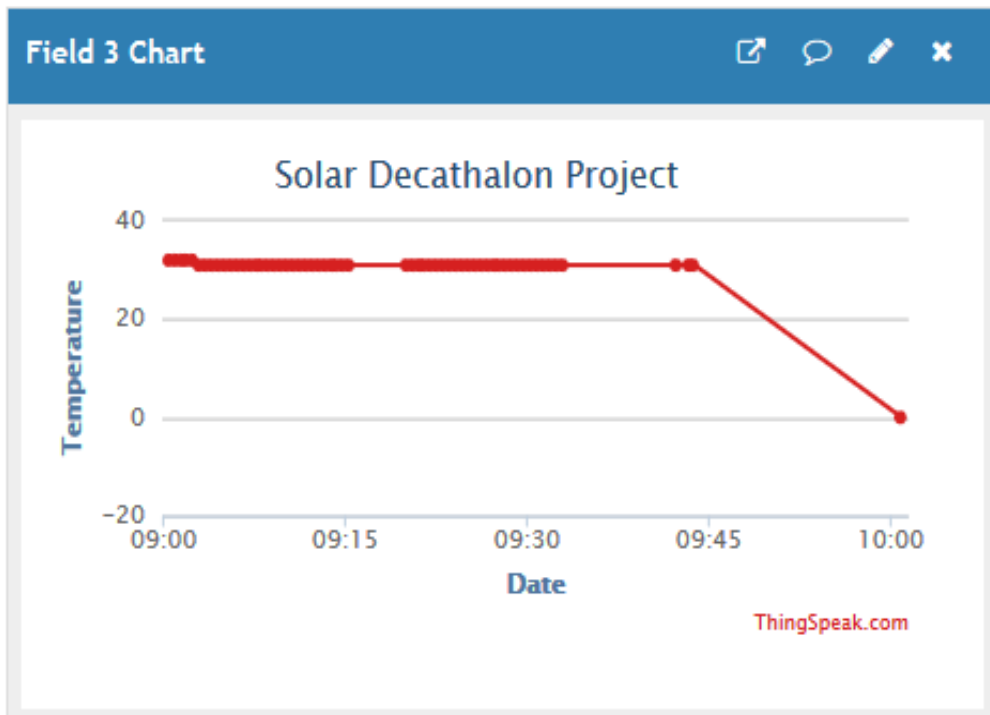

Fig 9.22. Graphical visualization of the Temperature sensor data

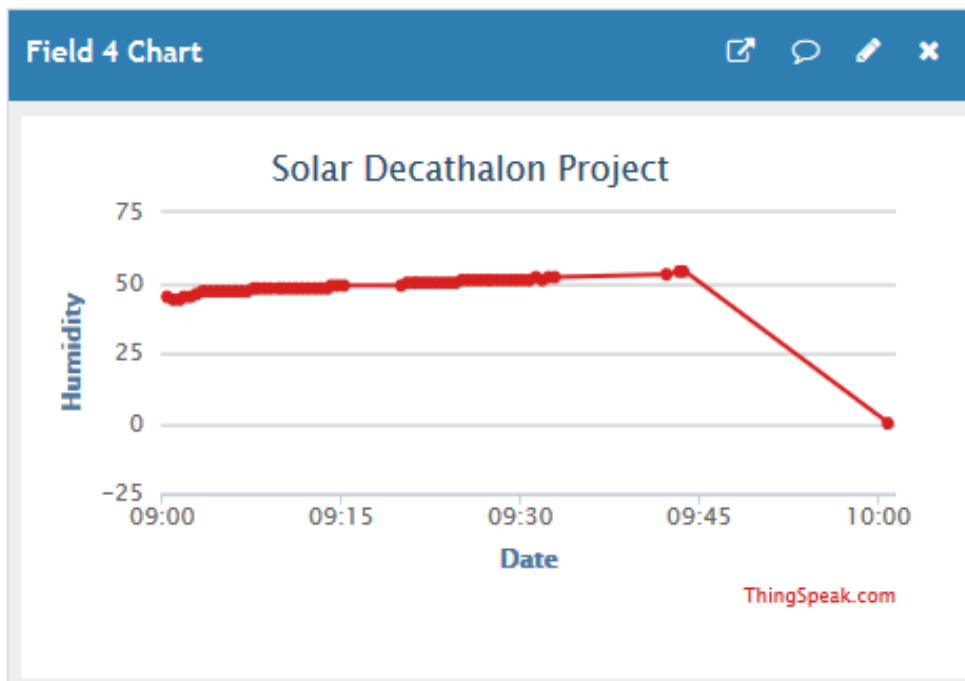

Fig 9.23. Graphical visualization of the Humidity sensor data

Clipboard		Font		Alignment		Number		
Q16		fx						
	A	B	C	D	E	F	G	H
1	created_at	entry_id	Air Quality	LDR	Temperature	Humidity		
2	2019-03-26 15:54:39 UTC	1	219	161	31	41		
3	2019-03-26 15:55:10 UTC	2	208	931	31	41		
4	2019-03-26 15:55:59 UTC	3	230	919	31	41		
5	2019-03-26 15:56:29 UTC	4	229	951	31	41		
6	2019-03-26 15:56:59 UTC	5	255	974	31	41		
7	2019-03-26 15:57:29 UTC	6	262	914	31	41		
8	2019-03-26 15:57:59 UTC	7	246	960	31	41		
9	2019-03-26 15:58:30 UTC	8	232	126	31	41		
10	2019-03-26 15:59:00 UTC	9	219	959	31	41		
11	2019-03-26 15:59:30 UTC	10	216	962	31	41		
12	2019-03-26 15:59:59 UTC	11	209	956	32	95		
13	2019-03-26 16:00:29 UTC	12	216	954	32	45		
14	2019-03-26 16:00:59 UTC	13	218	938	32	44		
15	2019-03-26 16:01:29 UTC	14	218	954	32	44		

Fig 9.24. Exported data from the Thinkspeak server

9.9.MOBILE APPLICATION

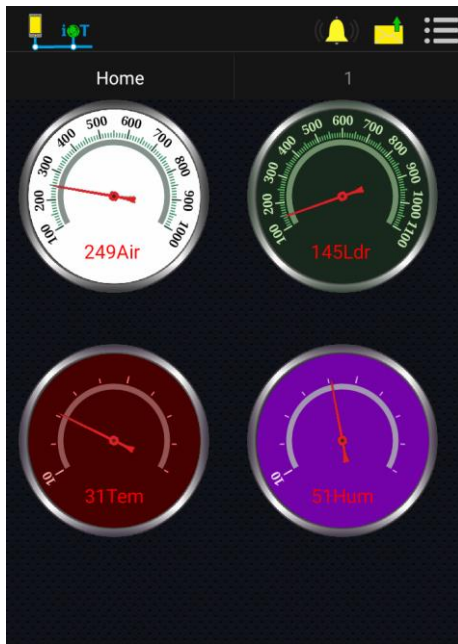

Fig 9.25. Monitoring the data through Analog Instrumental Data Meter

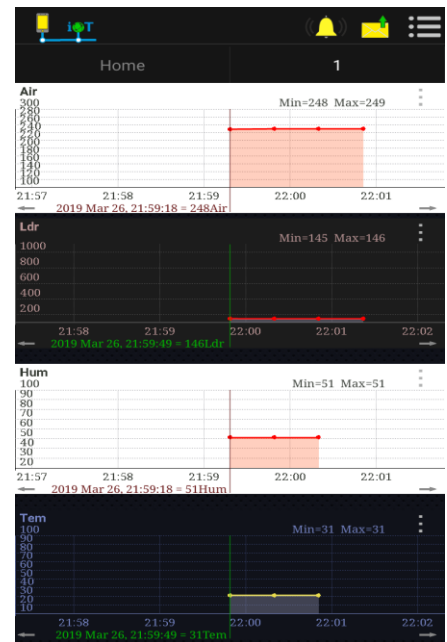

Fig 9.26. Monitoring the data through charts

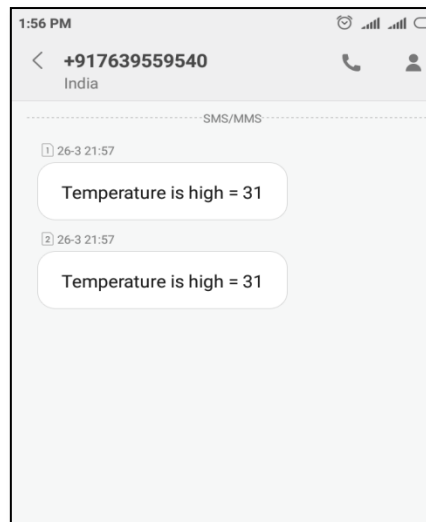

Fig 9.27. Mobile application sends alert message to the person, whose numbers are added into the mobile app

9.10. SAMPLE CODE

9.10.1. Sample code for testing the LDR sensor working process

```
sensorvalue=analogRead(sensorpin);  
  
Serial.println(sensorvalue);  
  
if(sensorvalue>990){  
digitalWrite(led, HIGH);  
delay(1000);  
}  
else  
{  
digitalWrite(led, LOW);  
delay(2000);  
}
```

9.10.2. Sample code for testing the Air quality sensor working process.

```
senVal=analogRead(A0);  
  
Serial.println("The ppm value of the indoor Air Quality ");  
  
Serial.println(senVal);  
  
if(senVal>200){  
Serial.println("Not good air please open all the doors");  
delay(2000);  
}  
else  
{  
Serial.println("This quality of the air is comfort for the breathing");  
delay(2000);  
}
```