

# **Homes for Middle Classes**

**Acc.No - 9847**

## Introduction

Naturalists tell us that the duration of the life of an animal must be normally five times the period it takes for the full development of its growth.\* This has been amply proved in the case of lower animals. If we observe the domestic animals, such as the horse, dog, cow, goat, etc., we shall find that they live almost the full span of life ordained to each by Nature. But if this principle is made applicable to human beings, we find that we are disappointed. Man possesses a very superior mental organisation and power of reasoning over the brute creation. He has utilised this to the fullest extent and devised means of defence to protect himself from the fury of elements by building houses, lighting fires, making clothes, cooking food and so on. He is thus expected to live longer than 105 years, i.e. five times the period of 21 years, which he takes for the full development of his skeleton. But what do we actually find? The average span of life of man, even in the civilised countries of Europe, was until three decades ago, only 42 years! But by careful attention to sanitation and rules of hygiene it has, of late years, been increased. Still it does not exceed 51 years! In India it is half of this, viz. 26 years! This, in other words, means that the average Indian succumbs to death when he is just on the threshold of maturity.

What is the reason? There must be some grand destructive agencies at work which shorten the human life. What can they be? If we observe minutely, we shall find that though man is subject to many diseases, from which the lower animals are exempt, for instance, certain diseases of mind, diseases descending from heredity, diseases caused by indulgence in vices or injuries, contagious diseases, etc. he, in his very attempt to outwit Nature by devising means of defence such as building houses, villages, towns, etc., has created around him conditions most conducive to diseases, which are responsible for shortening his life. Thus Malaria, Typhoid, Anaemia, Tuberculosis, malarial diseases, Cholera, Plague, etc. which take annually such a heavy toll of human life, owe their origin entirely to deficient light and ventilation, to damp, and to general insanitary conditions in and around our habitations.

That malaria, plague, cholera and other diseases should make their abode permanently in India, should in no way be surprising to those who know that the most fundamental principles of domestic sanitation and personal hygiene are set at naught either through ignorance or slovenliness or both.

The following description of a typical house in an Indian town will throw light on the causes of high mortality in India.

It is a house owned, not by a poor man but a well-to-do money-lender, situated in the heart of a town, lining one of the main thoroughfares, which is, by the way, only 15 ft. wide. It consists of three storeys, each having a separate tenement of three rooms. The ground floor tenement is occupied by the owner. All the three rooms are six feet wide and are one behind the other. The front room is 14 ft. long and is occupied by the business office of the banker and contains a moderate sized steel safe, two almyrahs, a chair, and two desks with mattresses in front, to squat upon. The central room is only 12 ft. by 6 ft. and is lit up by the diffused light penetrating through the door openings and a small horizontal window near the ceiling in the partition wall. This is the only bedroom of the family. The third room in the rear, almost of the same dimensions, is the kitchen, with a sink which is used both for slop water and bath and also serves as an emergency urinal. The sink consists of a large slab at the bottom and rough stones on the sides, once laid in bad lime mortar which however, has now been washed away, leaving wide crevices and thus making the side stones loose. It was intended that the water and urine from the sink should go to a pit close by, in which a sort of an Aroidæ plant (*Alu-Marathi* which is used as a vegetable, is grown, but the water soaks just near the wall and scarcely reaches the pit, causing damp to rise both in the floor and up the wall. Only the front room is paved, the other rooms having only a mud floor. The rear wall has a small window, but it is normally closed by day for fear of draught and by night, for fear of thieves. There is a small open space in the back yard, in which there is a latrine built of mud walls and mud floor. A steep staircase descends from the upper two storeys to the latrine as this is the only latrine for the benefit of all the three tenements on three floors. Another corner of the space is occupied by a cow-shed which has a mud floor and corrugated iron sheet roof which rests on the compound wall raised at the back and on wooden posts in the front, which is open. Between the cow-shed and the kitchen there is a well for drinking water, 4 ft. in diameter with a wheel and rope for drawing water. The wall round the well is low and when bathing and washing is done on a flat stone placed in front, there is every chance of soiled water flowing back into the well. A drain from the well in earth leads waste water from the well to the pit for the aroidæ plants referred to above. Between the kitchen and the latrine there is a muck-heap on which all sorts of rubbish such as sweepings from the house, garbage of vegetables, waste food from the cow-shed, leavings of food etc., are indiscriminately thrown. The children of all the three tenements make free use of the surrounding space answering the calls of nature, their excreta being left for the sun to dry. Whatever space remains over and above this is utilised for making dung cakes; even the parapet wall of the well and the rear wall of the house is occupied by them. There is a lane barely 4 ft. wide behind the latrine for the sweeper to scavenge. The bed of the latrine is at a lower level than that of the lane, and therefore, liquid sewage, stagnates in it to a certain depth. There are no shutters to the sweeper's door of the latrine in the rear, and the

fore, swarms of flies settle on the liquid sewage and fly from there and from the muck heap directly into the kitchen to sit on the cooked food for a change. The condition of the latrine cannot be adequately described ; suffice it to say, that it is used carelessly by the occupants of the three tenements and its mud floor is never cleaned by anybody.

The pit in which the aroidæ plants are grown is a breeding place and nursery of mosquitoes.

The occupants of the ground floor are ten in number, including four adults and six children. During the night, beds are huddled up as the space would make it physically possible in all the three rooms. In addition to this, some room is made available for the calf, by the side of a bed, to avoid a chance of the cow's milk being sucked by it, if it were tied in a corner of the cowshed. As one can naturally expect, the house is full of bugs and fleas, whom mosquitoes aid in busying themselves during night in disturbing the sleep of the inmates. No nets are used. Rats confidently move about even by day.

In front of the house, in a recess, by the side of the road there is a Municipal dust-bin which is never properly used by anybody and is always overflowing. Instead of the dust-bin holding *kutchera*, apparently the heap of the latter holds the dust-bin. Children of the neighbouring houses, who have no open space enclosed in their compounds, commit nuisance near the dust-bin. The rows of houses on both sides are two or three storeys high, and prevent the genial rays of the sun from penetrating the house during any part of the day.

This is no fanciful picture, nor one overdrawn, but a faithful one, depicting every-day life in the average village and town in India. The poverty-stricken people are still worse off than this, living in the slums of cities, where overcrowding is far greater than that shown in the above instance. This is due to the fact that the development of housing has lagged far behind the growth of population in recent years as shown below in the case of a few important industrial cities :—

## BOMBAY

Year	Population	Housing Accommodation		
		One roomed tenements	2-roomed tenements	3 or more roomed tenements
1931	11,61,383	1,75,001	38,559	40,349
1943	22,18,537	2,39,069	45,614	43,477
1946	27,74,054	2,37,901	52,069	40,540
1951	28,39,270	2,46,610	56,460	42,493

Thus for a 150% increase in population during the past twenty years there has been only a 35% increase in the number of tenements!

The Bombay Census Report of 1931 pointed out that 2,56,379 persons lived in rooms of *Chawls* each room occupied by 6 to 9 persons; 80,133 persons in single rooms, each occupied by 10 to 19 persons; and 15,490 in single rooms each occupied by 20 or more. 70 per cent of the infants under one year that die belong to these one room tenements.

Conditions have since become much worse with the increase in accommodation not keeping pace with the increase in population as shown above.

#### MADRAS

The population of the Madras City in 1941 was 7.77 lakhs, and that in 1951, 14.16 lakhs. The percentage increase is over 82, whereas the increase in housing accommodation did not exceed 25%. The number of houses in the city in 1951 was 1,05,000 for a population of 14 lakhs, which means an average of 7.5 persons per house for the whole city!

#### KANPUR

The population of Kanpur in 1941 was 4,87,324 and that in 1951, 7,05,383, an increase of nearly 45 per cent, while the housing accommodation has not increased by more than 12 per cent!

It is not sufficient to provide only adequate housing accommodation. It must be of good quality—sound in construction and conducive to health and comfort both in planning and environment. Good housing is synonymous with real home life, happiness and health, whereas bad housing spells inefficiency, squalour, drink, disease, and immorality. In this respect the conditions, particularly in large cities of this country are most appalling as shown below:

*In Bombay*—The *chawls* are buildings 2, 3, or 4 storeys high, so constructed as to be suitable for letting in separate tenements of a single or two rooms. Each tenement is separated by a party wall. There is a common passage 4 ft. wide either in front or rear. One or two wash houses and bathrooms and a few w. c. s. which are always inadequate, are provided at one end for common use. These *chawls* tend to establish a low standard of comfort and decency, and have often, a demoralising effect.

*In Madras*—The *cherries* consist of rooms 8' x 6' in size on the average of flimsy material erected on a low land several feet below the road level, and therefore invariably flooded during rains. The place is surrounded by drains full of sewage. There are no latrines. Herds of pigs wallowing in the streets serve as scavengers. The rooms are dark inside as there are no vents whatever. The entrances are so low that one cannot enter in or get out without bending oneself double.

There are 200 such *cherries* in Madras belonging to private owners, Government, Corporation and Trusts, and these quarter about one-third of the city's population !

*In Kanpur*—The following extract from the Report of the Royal Commission on Labour (1930) will throw light on the housing conditions prevailing at that time, which have since very much deteriorated with nearly 100 per cent increase in the number of factories during the past 20 years.

“Three quarters of the city of Kanpur is made up of private *bustees* or *ahatas*, which are houses either unfit for human habitation or in dire need of thorough overhaul. Most of them consist of single rooms, each about 8' × 10', with or without verandahs, and such rooms are frequently occupied by two, three or even four families. (They must be used only for cooking and giving shelter to infants, the adults using streets for sleeping by night). The floor is often below the ground level, and drainage, and public water supply, ventilation and sanitation are entirely wanting.”

*In Calcutta*\*—Over a million people live in dark, damp, katcha huts called *bastees*, which are about 5,000 in number, covering nearly one-third area of the city.

The houses in a *bastee* are small, single rooms, built back to back, with walls of earth or split bamboos plastered over with mud, with roofs of thatch, c. i. sheets or in some cases country tiles. The mud floors of many houses are below ground level, and consequently damp. The size of a room including a verandah is 80 sq. ft. with height 5 to 8 ft. and provides accommodation for 9 persons! Windows are lacking. There are green slimy ponds of stagnant water in between the *bastees*, full of putrid organic matter giving out obnoxious gases. These ponds supply the people with water for domestic purposes. The huts are huddled together in masses and pushed to the very edge of the ponds. The projecting eaves often meet one another and the enclosed space below them which is impervious to sun's rays is used as urinal by both sexes in common. Latrines, if they exist, are too few and filthy, so that men, women and children have to use drains and open ponds.

Infant mortality is a sensitive index of healthy conditions. For, infants respond more rapidly to the nature of environments than adults. It is no wonder, therefore, that babies in these places are born only to die, and those which survive, grow pale and sickly, and have no vigour of youth.

Judged from the criterion of infant mortality the following comparative figures of infant mortality of Bombay with three other countries show a striking contrast.

---

\*Administration Report of the Calcutta Corporation.

From the vital statistics of the Bombay city for the year 1944-45 the rate of infant mortality is still 203 per 100,000 as against 167, the average for the country, and against 46 of New Zealand, 56 of U.S.A., 57 of U.K. and 56 of Australia.

As one will naturally expect, this results in the wholesale massacre of the innocents. Because, of all the infants born in the Bombay City in 1936, 72.6 per cent were born of parents living in one room tenements, while, of all the deaths of infants during that year, these one room tenements accounted for 78.3 per cent !!§

Is there worse degradation imaginable? What wonder if one epidemic after another makes ravages from one end of the country to the other!

Pious expressions of horror at this are of no avail. Those who have a real sympathy and a sincere desire to help, must translate them into action and the sooner it is done, the better.

It was this that set the writer to think about and search after the means to secure two things. (1) Cheapness and (2) Sanitation. He soon found that the efforts required for the attainment of the first object must be oriented in the following directions:—

(1) Elimination of transport, which is synonymous with utilisation of local material to the maximum extent.

(2) Employment of local labour, and that too, unskilled labour as far as possible.

(3) Cheap materials.

Our wise forefathers knew this very well. Because, nearly 90 p.c. to 95 p.c. of our old houses, whether in villages, towns, or cities have been built of stones or brick in mud, or in some instances only in mud, with a free use of timbers and other materials produced locally in the main. The craze for lime and cement for cottage building on the part of the poor, is modern, and is restricted to large cities and areas round them, called suburbs.

It is pity that the present-day engineers and architects have totally neglected this 90 to 95 p.c. of building construction and concentrated their attention on the remaining 5 to 10 p.c. only.

Many of such houses, built some 200 or 300 years ago, are still stand in perfect order. Hence, it is beyond question that this system has stood test of time. There may be some inherent defects in it, no doubt, but it can be easily remedied by the application of the advanced knowledge of present day.

---

§ Administration Report of the Municipal Commissioner for the City of Bombay for the year 1936-1937.

This does not mean the writer is averse to, or decries the use of cement and lime and the modern science. Far from it. He has already written two books in which he has described the up-to-date methods of Building Construction. But the first-hand knowledge which he recently obtained by visiting several parts of the country to study the housing conditions, has convinced him that for the average Indian, who is very poor, they are rather expensive luxuries. Again, by using local material as far as possible, we help solve partially the problem of unemployment which so frightfully stares the country in the face. Besides, in addition to cheapness there are some special advantages which this system possesses. These have been discussed in the next chapter of this book.

It is true that we want more houses immediately to relieve the overcrowding, but a point of equal importance is that we want them to be built on the most sanitary principles. It is for this reason that nearly half of the book has been devoted to Domestic Sanitation and a special chapter on repairs and alterations added, in which practical hints on improving the sanitation of the existing buildings are given.

The book does not pretend to give the reader that amount of information which would enable him to build a cottage with its help from the foundations to the roof. The latter has been sought to be done in the author's other work viz., *Build Your Own Home*.<sup>\*</sup> The purpose of the present volume is to give the reader practical hints on economy and domestic sanitation, so as to enable a layman of the middle class to secure maximum health and comfort within a minimum amount spent.

However, cheapness is not always synonymous with economy. There are primarily two factors to be considered: one, the initial cost and the other, the maintenance charges. An item which is slightly costlier in the beginning, but saves a lot for upkeep, is more economical in the long run. Again, a note of warning must be sounded against the employment of unsound, cheap material of an inferior character, which soon deteriorates and becomes unhealthy, or of bad workmanship, which one, in one's fondness for economy is tempted to overlook or connive at. These defects tend to foster in them a sense of carelessness and untidiness. How is it possible to keep a house neat and tidy, in which the plaster of walls is continually falling off in patches, the joints in woodwork of the upper floors opening out and allowing loose earth to drop on a slight shaking; roof leaking and causing damp in floors and walls; the opening joints in woodwork of doors, windows and cupboards, etc., giving room for dust to collect, and bugs and other vermin to breed; drains choking very now and then and causing emanations of foul gases, etc.? Even the dullest housewife would soon be disheartened and become dull to the sense

---

<sup>\*</sup> *Build Your Own Home* in English or *Sulabha Vastu Shastra* or "Modern uses and How to Build Them" by the author, either in Marathi, Hindi or Gujarati.

of dirt and uncleanliness. The spirit of tidiness, once gone, leads to untidiness in other things such as dress and personal hygiene and makes the house dreary, filthy, and squalid, and no longer a pleasant, cheerful and sweet home.

If a pleasant-looking, comely cottage, planned for comfort, and sound in construction, howsoever humble, is provided, the occupants instinctively take a lively interest in keeping it neat and tidy. Once they catch this spirit in right earnest, it is easy and inexpensive to render it more pleasant and attractive by little things such as a wash of economical distemper, planting a few roses here, a bed of seasonal flowers there, a few flower-pots at another place, and so on, and thus gradually develop an artistic taste for decoration.

Just imagine a cheerful wife and gay children taking delight in watering flower plants in the evening, and looking with pride at the flowers grown by their labour! Could there be a better recreation for them? Could there be a more refreshing sight than this to the humble clerk or the school-master returning home, exhausted after the day's hard labour?

In conclusion the writer craves indulgence of the reader for appreciation of his humble but sincere attempt to ameliorate the housing conditions of his poor countrymen, fully conscious as he is of the many defects and imperfections in the book.

## Materials

: I

The question of material is of the greatest importance in building construction, because, upon it depends, to a very large extent its economic success. Materials which have to be transported from long distances are costly. Sometimes the cost of transport is twice or three times that of the materials themselves at the site of their production. Restrictions imposed by heavy tolls on roads, customs charges and freight charges on railways, etc., tend to check the transport and enhance its cost. Hence, for economic success of a building, materials which have to be transported from long distances must be avoided as far as possible. This is tantamount to saying that local materials available must first be explored, and ways and means devised for utilising them fully, so as to eliminate, or at least reduce to a minimum, the unnecessary cost of transport.

Again, materials always look well in the place where they are naturally found, and very unbecoming, away from it. Local materials are easily adjustable to their natural surroundings; they tend to retain their tradition, and maintain the architectural aspect of the place.

Amongst the materials required for building, those useful for walling form the main bulk. Next come timber, mortar, roofing materials, ironmongery, etc., in their descending order of cost in the estimate.

Walls are most commonly constructed of either stone or burnt brick or a combination of both. For cheap houses sun-dried mud brick or mud also is often used—a point to which we shall come later on. When a choice between stone or burnt brick is to be made a layman is often very much puzzled as to which of the two is to be preferred. We shall therefore briefly discuss the merits and demerits of each.

### Brick Versus Stone

(1) From the fact that we see several stone buildings exposed to elements still surviving the vicissitudes of ages, we can say with certainty that stone is more durable than brick and that it is capable of resisting the atmospheric and other external influence to a far greater extent than brick. But at the same time, we must not forget the fact that even the most optimistic person never thinks or imagines that his house would last for several hundred years. He would be content, if it lasts only for a hundred or hundred and fifty years. And we actually see brick houses built some three hundred years ago still standing in perfect condition in defiance of the fury of the elements.

Hence we can justly say that for our practical purposes a brick house is as durable as a stone house, provided the brick is of a good quality.

(2) From the point of view of protection from thieves and house-breakers a brick-in-mortar wall is as strong as, if not stronger than, a stone wall. This is so because to make an opening into a stone wall, it is comparatively easy to rake out joints on all sides of a stone and to pull it out whole, but the adhesion of brick to mortar (good, of course) is so great that in order to pierce a hole into a brick wall, small pieces of brick have to be chipped off, which cannot be done without a considerable noise and severe shaking of the whole wall.

(3) In respect of ornamental or plaster work, brick possesses an undoubted advantage over stone. Because in the first place, plaster sticks to brick more firmly than to stone, and secondly, brick, by its very soft nature, allows its being roughly cut with an axe to the approximate shape, which can then be improved upon with plaster and be given the desired smoothness for decorative effect. With stone this is not possible, or at least is very difficult and expensive.

(4) Brick having right-angled square shape is more suitable and cheap for corners. Even for jambs of doors or other work involving an acute or obtuse angle, the very fact that it can be easily cut makes it very convenient. Its size and handy weight make it very easy to manipulate.

(5) Brickwork requires a fixed quantity of mortar and on account of its flat, square shape there is a less chance of its remaining hollow at the hands of bad workmen. In stonework, there are far greater chances, of waste of mortar occurring in the filling of the hearting, and also hollows being left unfilled, if the masons are careless.

(6) A still greater advantage which brickwork possesses over stonework is that walls of over 3 in. thickness with brick on edge, or 4½ in. with brick laid flat, or 9 in., 14 in. or any width above this can be easily built. The least thickness of a stone wall, on the other hand, is 15 in., in which case also it is not regarded strong enough for supporting walls of the upper storey because unless a stone wall is at least 18 in. thick, on account of the comparative big and irregular size of the individual stone, there is no sufficient bond in it. A brick wall only 14 in. thick, on the other hand, can support walls of the upper floor and an additional advantage is that for the same quantity of brickwork, rooms are made 4 in. wider than those with 18 in. stone walls.

(7) Another advantage brick possesses over stone, particularly in tropical countries, is that brick does not absorb and radiate so much heat as stone does.

From the foregoing discussion it will be seen that in point of durability and strength, brickwork is certainly equal to stone work and superior to it in several other respects.

## MATERIALS

However, the quality of bricks manufactured in India, except perhaps in the Punjab and some other places, is poor. Even the Bilimoria or Calicut bricks which are highly praised, do not stand comparison with bricks of English manufacture. If the quality improves in future there are bright prospects for Brick industry in India.

The disadvantages of brickwork are that it absorbs moisture and is, therefore, unhealthy particularly in damp situations; that so long as the quality is not satisfactory, it requires plastering on the outside. The plaster not only increases the cost, but its repairs and the renewal of colour on it have to be constantly attended to at a considerable recurring expense. Even if the colour fades, or the surface is disfigured by atmospheric influences, it presents a shabby appearance. A third disadvantage is that though it absorbs less heat than stone, having once absorbed, it parts with it but very slowly. Hence, brick walls exposed to sun take a longer time to cool down during night.

As regards costs, very often the apparently higher rate of brickwork leads one to imagine that it is more costly than stone-work; but a little consideration will show that where stone walls 18 in. thick are required, brick walls, only 14 in. thick, do very well and therefore, within the same volume of masonry a longer wall can be constructed in brickwork than that in stone-work. Hence the rate has to be reduced to  $\frac{14}{18}$  for comparison with that of stonework. An example will make this more clear; the rate for brickwork in lime in Poona is Rs. 120/- and that for uncoursed rubble stone masonry is Rs. 112/-. Now the rate of Rs. 120/- if reduced to  $\frac{14}{18}$  because brick wall is 14 in. thick, while stone wall must be 18 in. thick.  $120 \times \frac{14}{18} = 93.5-0$  to which must be added the cost of plastering on the outside which brickwork requires. 100 cft. of 14 in. wall will have 86 sq. ft. of outside surface ( $100 \times \frac{12}{14}$ ). The cost of plastering 86 sq. ft. at Rs. 30 per 100 would be Rs. 25-13-0. Total cost of 100 cft. of brickwork is Rs. 120-2-0. Hence, in this particular instance both cost the same thing.

It is worth mentioning here that the thicker the brick, the better it is from the point of view of economy. Because there being less number of joints, less mortar is consumed and there is also a saving in labour, as the progress of work is more rapid.

Regarding other materials which are locally available and used for walling such as wattle and daub, earth, bamboos and wooden boards, etc., they will be discussed later on under "Walls."

Next in order of importance comes timber. Teak is undoubtedly the best, but though grown in forests in almost all parts of India, it is often costly on account of the long distances from which it has to be transported. In such

places, some of the local varieties of timbers would be found to give perfect satisfaction, if used in positions in which they have been proved, by local usage, to give best results. For example, *Ain*\* (Marathi) is a strong, durable variety of timber but is unsuitable for use in exposed positions, where it cracks by the heat of the sun. Otherwise, it is an excellent timber, as it keeps well in damp situations—even under water, and is not attacked by white ants. Similarly *Neem*† (Margosa) is excellent in all positions except moist or damp ones in which it warps and bends. Hence, it is good for door frames, posts, beams, lintels, etc., inside the house but not for rafters or panels of doors and windows in exposed walls.

Recent research on timbers has shown that there are a number of indigenous soft woods, which, are very cheap and which can be made stronger than and as durable as teak after some treatment.

There are a number of strong and durable varieties of timber in India but many of them are attacked by white ants. Such varieties should be used only in such positions as would allow them to remain exposed to view and be easily replaced when necessary, without requiring any considerable part of the building to be dismantled; e.g. shutters of doors, windows, shelves, posts (not buried in wall), furniture, etc.

Even more important than the white ant is the other enemy of timber to be most feared. It is "dry rot". It is a kind of fungus, which once established, spreads over and eats into the entire piece with marvellous rapidity. It generally commences in sapwood. A scantling apparently sound may have been entirely hollowed out inside by dry rot. Its presence can be detected by gently tapping on the timber, when it sounds hollow, which is an indication of the fibres having been reduced to powder. The cause of its appearance is damp and want of ventilation. It is unfrequently due to the timber being insufficiently seasoned. It is found mostly in unventilated wooden floors, damp cellars, in timbers buried in walls such as ends of beams, wall plates door frames, etc. Once it attacks timber there is no remedy but to remove the whole of it, with all the traces of the fungus. Application of one or two coats of hot coal-tar is a preventive remedy. But the timber must be previously thoroughly dry.

A suggestion to laymen, while using timber will not be out of place here. It is this: when a scantling is used for resisting a force coming at right angles to its length, as for instance, like a beam or rafter, its stiffness varies as

---

\* Equivalentents of *Ain* in other vernaculars are—*Matti* (Kannad); *Sagada* (Gujarati); *Sain* (Hindi); *Maddi* (Tel.); *Usan* (Bengali); *Anemui* (Tamil).

† Equivalentents of *Neem* in other vernaculars are—*Nimb* (Marathi); *Vepa* (Tel.); *Vepum* (Tamil); *Bevu* (Kan.); *Said* (Hindi).

the product of its breadth and the *square* of its depth which is indicated by the formula :—

$$S \propto BD^2.$$

i.e. Stiffness varies as Breadth  $\times$  square of Depth.

Therefore, if a scantling of more breadth is used, there is some gain in strength no doubt, but it does not add to its stiffness or resistance to bending; but if the depth is increased even slightly there is considerable difference in respect of stiffness. For example, see the three beams :—

No.	Beams		Sectional Areas and Costs Vary as	Resistance to Bending Varies as
	Breadth	Depth		
(i)	4"	5"	20	100
(ii)	4"	6"	24	144
(iii)	3"	7"	21	147

This shows that though the second is the costliest of the three, being of greatest sectional area, it is weaker than the third, and the third beam which costs almost the same as the first, is 50% stronger. Of course, if the breadth is too small in proportion to the length, the beam buckles sideways.

#### Mortar\*

It would be out of place here to explain how mortar is prepared, what constitutes a good mortar, or how a layman can apply a rough test for distinguishing it from a bad mortar. All this has been done in great detail, especially from a layman's point of view, in the author's book *Build Your Own Home*. It is only the economical aspect of all materials, including mortar, that is sought to be discussed here.

There are two varieties of lime used in the preparation of mortars. One, *fat* lime and the other, *hydraulic* lime. Fat lime is one which, when slaked or treated with water, makes a hissing noise, steams and bubbles up, giving out considerable heat, and increases in bulk. It is good for plaster or white-washing and is used with *pan* (betel leaves). It derives all its strength by chemical reaction with carbonic acid gas, which it absorbs from the atmosphere. Hence, excepting in positions like that of plaster, where it freely gets carbonic acid gas, it lacks in strength. It does not set in water and keeping it moist does not help it gaining strength.

---

\* The word 'Mortar' has been used in this book to convey the sense of anything that binds together. Hence it is not necessarily of lime; it may contain lime, cement, or mud, and, therefore, may be called lime mortar, cement mortar, or mud mortar.

Hydraulic lime, on the other hand, slakes but slowly, and while doing so, does not give out so much heat, nor increases so much in bulk. It sets in water and moisture helps it in hardening. It possesses considerable strength.

Of course, hydraulic lime is the best as a building material. But, it is not locally available everywhere. Still, one need not be sorry for it and try to transport it from long distances; because in the first place, there is very little transverse or horizontal stress in ordinary buildings. Practically the whole stress is of the compressive nature, that is, one coming vertically down. Hence mortar of strong hydraulic lime is not necessarily required for ordinary buildings. Secondly, if more strength is desired, the deficiency of it in the fat lime can be made good by grinding *surkhi*, or powdered burnt clay with it. The latter also increases its bulk.

The strength of the fat lime mortar is slightly improved by mixing it with a slightly greater quantity of sand than ordinarily required because sand tends to make it a little porous and allows it a greater chance of absorbing carbonic acid gas from the air, upon which its strength depends. Incidentally sand increases the volume of mortar and reduces its cost.

If the fat lime is of a pure, unadulterated quality, sand to the extent of 2½ to 3 times its bulk, could be safely mixed with it to make the mortar suitable for domestic buildings. Where sand is not available at a cheap rate because of its transport from a long distance, *surkhi* may be used in its place either partly or wholly.

Lime mortar, after all, is an expensive luxury, which middle and lower class people cannot afford. I have already remarked above that domestic buildings have very little transverse or horizontal stress coming on their walls. Perhaps the only transverse stress is that of wind pressing at right angles to their face, but as such buildings are not very high, or, of any considerable length unsupported by cross walls, that stress is negligible. Hence for all practical purposes, there is little justification for this expensive luxury. All that is necessary is to make the external faces of walls reasonably water-tight, which is, invariably or at least in the majority of cases, done in India by means of either cement pointing or lime plastering even in the walls in which lime mortar has been used.

This fact appears to have been fully recognised and advantage taken of it by our wise forefathers. Because, if we examine the old domestic buildings—even those belonging to the nobility and richer classes of those days, standing in defiance of the meteorological changes of the past several hundred years, we shall see them invariably built in mud mortar. They have used lime mortar only in such places as terraced roofs, parapets, bathrooms, drains, etc.,—places where water-tightness is required. Lime mortar is found to have been used in walls of palaces, forts and some of the public buildings, such as temples and mosques. Even in our own day to-day practically cent per cent of the

houses in villages and over 90 per cent of those in towns even of recent construction are of walls with mud mortar, with some special treatment for exposed surfaces. Even in large cities like Bombay, Calcutta, Madras and others many old houses counted by hundreds will be still found to be of a similar construction. It is only very recently, perhaps under the compulsion of Municipal bye-laws, that new houses erected on old sites in large cities and new bungalows built in suburbs, that have walls built with lime mortar, and on extensions on the outskirts of large towns, cottages have recently been springing up after this fashion (though there is no compulsion of Municipal authorities,) in blind imitation of the bungalows of their "refined" city brethren. It is a pity that none of the present-day engineers and architects takes interest in reviving or rather preserving this time-honoured economical method of building construction with the direful result that we are fast forgetting it and it is becoming a fashion of the day to build everything in lime mortar though the majority of our people cannot afford it.

The mortar ordinarily used in buildings is mostly or entirely of fat lime. Again, if the sand mixed in it contains earthy matter, or if the mortar is not ground well—things which are of very common occurrence—the resultant lime mortar is no better than the specially prepared mud mortar, and yet its cost ranges from Rs. 60 to Rs. 90 per 100 c-ft.

All earths are not suitable for preparing mud mortar. The best sort is the earth\* which is more or less impervious to water, that is, is the least absorbent and which, therefore, allows water coming in contact with it, to flow away without allowing it to penetrate itself beyond the skin layer of a quarter of an inch at the most. Still, it must possess freedom from both excessive swelling when mixed with water and excessive shrinking when getting dry again. Otherwise, it will form cracks while drying. Earths containing too much of clay are bad in this respect. They can be improved by an admixture of sand in it, the proportion of which can be determined by actual experiment.

The ideal earth for this purpose is found in and around towns and villages, where the earth, perhaps by the constant treading of people and cattle, and by the action of the manure usually produced in homesteads, attains this property of imperviousness to water to a remarkable degree. It is generally whitish in colour and therefore goes under the name "white earth." Mixed with cow-dung, it is used as a plaster by village people for annual repairs to mud walls and keeping the wall surface both inside and outside. It is, in fact, the poor man's whitening for giving an annual wash to the walls of domestic buildings. On account of its remarkable property of imperviousness to water it is successfully used on the top of terraced roofs. A six inch layer of this

---

\* This subject has been treated in greater detail further on under "Earth walls" and in Appendix 1.

earth on a flat wooden ceiling is sufficient to afford excellent protection from rains. The next best earth is what is called 'Chopan' soil in the Deccan. This is brown, grey, or yellow in colour and its main characteristic is that it is non absorbent and hard—so hard and compact indeed, that vegetation does not thrive in it as it does not allow its roots to penetrate its surface, and its compactness prevents their aeration.

In many places this white earth is found to be not satisfactory in point of imperviousness to water. This is due to the preponderance of calcium (lime) and mostly potassium salt (nitre), which absorb moisture from the air. Again, there are places where the white earth is, to all practical purposes, impervious, to start with, but in the course of a few years it loses this property and shows, day by day, an increasing tendency to absorb moisture from the air and become damp. The earth near the ground surface in walls showing such damp patches loses coherence and comes off in powder at a slight touch. Hence, people prefer to transport from long distances, special earth, popularly but wrongly called *Khari Mitti*, which is, in fact, chopan earth, to rather using this local white earth on roofs. This *Khari Mitti*, too, deteriorates within a few years.

The remedy for this evil is to leach or wash out the salts from such earths. The easiest and cheapest way of doing this is given below.

Spread about a six inch layer of loose straw, hay, or any such materials as would facilitate drainage. Make on top of this a heap of the screened loose earth, say about 2 ft. in height. Make a hollow on the top of the heap and fill it with water up to the brim. As the water sinks down add more and continue this for a number of days till the water level does not appreciably sink down. It will be found that most of the salt will have gone out with the water which percolated through the bed of straw, leaving only impervious earth in the heap.

It was the old practice to keep such heaps for "Souring" for a month or more before they were broken up and mixed with water for forming mortar especially for plaster. The whole secret of making the earth hard and impervious to water lay in this process of "Souring" which, in fact, was nothing but one of leaching out salts.

#### Making Artificial White Earth.

In places where white earth of the best quality, or even that of inferior quality, impregnated with salts as described above is not available, any earth can be artificially rendered impervious by the following device :—

The process involved is just the opposite of what is done for improving heavy soils and making them suitable for agriculture by "liming". We want to replace lime by sodium salts or "sodiumise" the soil. For this dig out the earth to be treated and remove the top layer of about 9 in. of it, which is

of decaying matter and roots of vegetation, technically called "humus." Excavate the earth from the lower stratum and put it in a shallow heap to dry. Sift it through a screen of about  $\frac{3}{4}$  in. mesh to exclude stones and especially nodules of lime *kankar*. Then mix with it any sodium salt such as, salt deposit from near the sea shore, surface earth from patches of land, spoilt by the rise of underground water-table, called *Reh* or *usar* lands, etc. The distinguishing feature of the latter is that it is always found in a powder of brown or grey colour, tastes salty and bites if applied to the tip of the tongue. Failing to obtain these within a reasonable distance, mix impure variety of common salt, offered by Government at a very cheap rate for manurial purposes, and failing to get even this, use sea water. The exact proportion of salt required depends upon the nature of the earth proposed to be treated and the degree of concentration of the salt in the stuff. This, usually not exceeding 5%, may be determined by actual experiments, by trial and error, and that proportion, which gives the best result in the particular case may be finally adopted.

The salt mixed in the earth should be leached out by making heaps on a bed of straw and filling water in the hollows on their top as described above. The more perfectly the salts are leached out the more impermeable would the earth become. The most satisfactory way of doing this is to stir the mixture thoroughly in water in a masonry or iron tank, allow the earth to precipitate, and remove the water from the top. This may be repeated once or twice again. But this is possible only when the quantity of earth to be dealt with, is small, otherwise, the cost becomes prohibitive. Hence, the above simple and more practical method is suggested.

In short, in order to prepare 'white' or impervious earth artificially from any earth available, add any variety of sodium salt, whichever is cheaply available even in an impure state, such as a deposit of common edible salt ( $\text{NaCl}$ ), washing soda ( $\text{Na}_2\text{CO}_3$ ), glauber's salt ( $\text{Na}_2\text{SO}_4$ ) etc. and then *wash the salt out*.

This is not the place to enter into the chemistry of the soils and explain the exact chemical actions involved. But for the satisfaction of those who want to go more into details a note has been given in the Appendix No. 1.

This impervious earth, either natural or artificial, as it is compact and does not hold water, is generally free from swelling when wet, and from contraction when dry again, and, therefore, the cracks if formed at all in it are only superficial. Still, it can be improved even in that respect by mixing either sand or some other soil with it. Thus, if clayey earth is mixed with sandy soil the resultant mixture is quite good. The object to be aimed at is that there should be sufficient clayey material to give the mortar hardness when dry, and there should be sufficient sand or sandy material to prevent undue shrinkage when drying.

## Foundations

## II

The walls of a house must be built on a sufficiently solid and substantial foundation to prevent them from sinking or settling into the ground which usually causes them to crack. They have also to be formed of sufficient thickness to secure a due amount of stability and afford protection from the heat of the sun.

It is quite true that it is impossible to rectify weakness once allowed in the foundations when the walls are raised, and therefore, one should always err on the safe side by spending a little extra money to ensure the soundness of foundations. But it is observed that in the majority of houses of the middle class people in India, which are comparatively quite light buildings, much money is unnecessarily wasted in excessive depths. It is an erroneous impression that an increase in the depth of foundations always increases the stability of walls.

The ground surface, unless it consists of rock or hard *murum*, is generally loose and full of roots of vegetation upto a depth of say about 9 in. If we excavate deeper than that depth, we find that the soil grows more and more compact. But there is a limit, of the original virgin soil, which, when once reached, the compactness increases but very slowly, if at all, if the strata are uniform. Every soil has a certain amount of bearing power, and if the intensity of the load put on the soil is within the limit of that power it does not sink.

If the compactness remains the same and if we still go deeper for foundations, what we do is, we add more load on the foundations and thus in seeking to strengthen, we actually weaken them, in spite of increase in cost.

There is some specific object in digging to a depth of about 3 ft. in the soil. It is generally held that the effects of atmospheric and other influences do not reach beyond that depth. That is to say, the foundations in soil, if carried to this depth, are not affected by rain-water soaking into the soil, by acids dissolved in the atmosphere causing it to decompose, and by rain-water flowing on the surface eroding it. A depth of three feet is generally regarded sufficient to resist all these influences.

Hence, unless it is a black cotton soil which requires a special treatment, it is not advisable, in the interest of economy, to go more than 3 ft. below the ground surface and as a general rule, even in the case of black cotton soil or of the made up ground of recent filling it is uneconomical to excavate below 6 feet, if we do not strike *murum*, or rock, one or the other of the remedies

mentioned below, whichever would suit the particular circumstances will be found to be cheap and effective. These are :—

(1) To lay one or two layers of boulders at the bottom of trenches, to flood them with water, and to ram them hard, so as to prepare a reasonably unsinkable base for the walls to build upon.

(2) To fill the lowest two feet of the foundation trenches with dry sand, packed well, upon which the footings of the walls may be built. The word "sand foundations" might sound rather queer to a layman who may be led to suppose that he is proposing "to build on sand", but in reality sand is practically incompressible and hence, if the sides of the trenches are not likely to yield by horizontal pressure conveyed by it, sand-filling forms an excellent method of strengthening foundations under certain favourable circumstances.

(3) Excavating pits at intervals down to the *murum* or rock, filling them with lime concrete and connecting them all together by means of arches of concrete, a little below the ground surface. This is a very simple and cheap method, as the arches do not require any centering. They take the shape of the excavation.

(4) Widening the foundation trenches so as to distribute the load on a greater area and laying lime concrete at least two feet in depth above it. The latter serves as a beam and helps in equalising the pressure above.

These and a few other simple devices have been described in the writer's *Build Your Own Home*. In order to avoid repetition of the same, only a casual reference to them has been made here.

If the ground is of doubtful nature trial pits should be excavated and the soil carefully examined. Black cotton soil swells when wet and shrinks very much again when dry, and thus forms a very treacherous foundation. The only device which has so far been found successful in resisting its effects is to construct a reinforced cement concrete (R.C.C.) band 4 to 6 inches thick all round, of the full width of the walls at the plinth level. If the soil is very deep, another band of the same thickness may be similarly laid at the level of the top of windows and doors, which also makes lintels unnecessary. Detailed information about this also, has been given in the book mentioned above. If this is done, the foundations need not be taken more than four feet below ground.

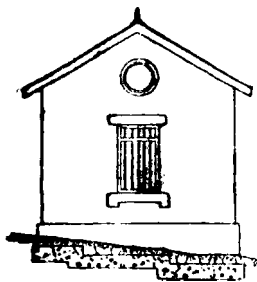

Fig. 1.

When the ground is sloping steeply, it is possible to effect economy by stepping the foundations as shown in the sketch (Fig. 1). Care should be taken to make the lower layer overlap sufficiently the upper, otherwise a weak spot may be formed at the junction of the step.

### Filling in the Foundations

If the soil is firm and the structure to be raised is a light, ground floor building only, it is not necessary to lay lime concrete in the foundation trenches. All that is necessary is to pack stones close together in mud mixed with a certain proportion of sand or soft *murum*. The stones should be as large as possible, laid on their flat surface and the intermediate spaces should be filled with smaller stones and chips packed in mud under a stroke of a hammer. Even boulders may be used as they are found in natural state, i.e. even without breaking them.

It is desirable to use stone up to the plinth level but where it is scarce, e.g. in the alluvial tract of Sind or Punjab, over-burnt or well-burnt bricks may be used.

### Hints for Economy

If the soil is not sufficiently compact, or if the building is to have several storeys and, therefore, lime concrete has to be used, the following hints may be adopted for economy :—

(1) For lime concrete, a proportion of 2 to 2½ parts of stone metal to one of mortar is generally used. But if the stone metal is graded, i.e. if all the sizes from 1½ in. to ¼ in. are used, by mixing gravel and sand in certain proportions, the quantity of the lime mortar can safely be reduced. By adopting the usual proportion of 2 to 2½ of metal to one of lime mortar what we do is, we fill all the voids of the metal by means of mortar. By using aggregate of varying sizes, as suggested above, we fill the voids in the metal by gravel, the voids in the gravel, by sand, and those in sand, by mortar and thus ensure even greater compactness by using less mortar, and stone metal.

(2) It is possible to reduce the quantity of metal in the concrete and effect economy by using a fair number of big stones in the body of the concrete. This also adds to the strength of the concrete. The process of doing this properly is described below :—

(a) First lay a 4 to 6 inch layer of concrete and ram it well.

(b) On the top of this, lay some two inches of concrete and before it is rammed, place big stones with their flat or broad surfaces at the bottom, taking care that they are thoroughly embedded in the concrete below.

(c) The stones should not touch each other. It is advisable to leave sufficient spaces between them for the facility of packing concrete all round them. As the concrete is laid in between and round the stones, it should be rammed by a wooden handle or pointed iron rammer.

(d) The top should be finished with a 3 inch layer of concrete and the whole thing should be rammed well.

This sort of concrete is called "Plum concrete." It is not only cheaper than ordinary concrete but, if properly made, is also stronger.

(3) In most cases, lime concrete is cheaper than rubble masonry. Besides, the small pieces of stone in concrete ensure greater compactness when rammed well than the rubble masonry which is likely to remain hollow at the hands of a careless mason. Hence, it is both economical and sound to bring the concrete layer up to 6 inches below the ground surface in the case of external walls and up to ground level for internal walls. In the case of external walls it is necessary to keep the concrete at least 6 inches below ground to prevent its being exposed to view, if by chance the ground is scoured or denuded.

(4) If the cost of concrete is considerably less than that of uncoursed rubble masonry, laying concrete even up to the plinth level in the case of internal walls would save a lot of money. It is necessary for this to fill in earth up to plinth first, then excavate trenches in it just above the concrete already laid below and fill concrete in them. As an alternative the walls should be provisionally lined with stones, or bricks or wooden boards to facilitate filling and ramming of concrete. They can be afterwards removed and used elsewhere.

### Plinth

It is not prudent to curtail the height of the plinth for the sake of economy. The determination of the exact height depends upon several considerations. In damp situations or marshy sites, the higher it is, the better. If the soil is of non-absorbent nature and the site is sloping sufficiently, so that rain-water is easily drained away from the building, the plinth need not be very high. 2 to 3 feet should generally be sufficient for ordinary conditions. In no case should it be less than 1½ feet.

### Hints for Economy

(1) It is customary to provide some sort of coping at the plinth level, either of fine dressed chamfered stone or cement concrete 4 in. to 6 in. thick all round the building. Its purpose, viz. to allow the rain-water from the face of the walls to flow away from the masonry of the foundation is, in most cases, not properly served as a drip moulding is not provided. Hence, it serves no purpose beyond that of a decorative effect. It may, therefore, be safely dispensed with in the interests of economy, and considerable saving effected.

(2) Money is often unnecessarily wasted even in villages, where good stone is available, in building plinth of very finely dressed large stones. This practice on the part of the middle and lower classes is to be severely condemned as it does not add to the strength of the building. This waste, if stopped, can be utilised elsewhere in items which contribute to increase convenience and comfort.

(3) Very often the site is sloping steeply. If there is a considerable difference of levels between surfaces at the front and the rear of the house, there are two ways possible for economy.

(a) To design the floors of different rooms at different levels according to the slope of the ground. But this is not recommended as it increases the labour of the occupants in climbing up or down while moving from one room to another—a permanent disadvantage.

(b) To keep the floor level of the entire house the same, which, of course, must be a little above the ground surface on the higher side, and taking advantage of the slope, to construct a cellar below the floor on the lowermost side. If the floors are kept at different levels, there is some saving in the plinth masonry, no doubt, but as the roof also cannot possibly be constructed at correspondingly different levels the ultimate saving is not worth consideration.

#### Cellar

A well-ventilated and lighted dry cellar is an advantage, particularly in small cottages in the tropical countries. Many and varied are the uses of a cellar. First, it affords an absolute protection to the room above it, from the evils arising from damp ground. Secondly, it serves as an excellent place for storing certain articles which keep well only in cool places of equable temperature, away from strong light. Thirdly, though even in the best situations its use as a bed-room is not commendable, it certainly provides a cool sitting-room in hot climes during part of the day when the outside heat is unbearable. In such places, a cellar is a necessary adjunct from the point of view of comfort. The fourth and the most important use of a cellar in modern days is as shelter from possible air raids.

Many people, not accustomed to the use of these cellars or '*Tahkhanas*' as they are called in Northern India, experience, upon first entering, a pleasant sensation of coolness and comfort on account of a considerably lower temperature in these sub-terranean chambers than that outside, but in a few moments a feeling of disagreeable stuffiness or oppressiveness is felt by them and free perspiration is caused. This is due to two reasons: one is, that a large amount of water vapour caused by the damp is present, and secondly, the air in the cellar is stagnant. If, therefore, adequate means are provided for frequently changing the air, this course of discomfort would no longer remain.

Still, it is neither practicable nor desirable to construct a cellar in every house, though it costs only about 60 per cent of that of the ordinarily built-up floor area. It is a common belief that rocky or *murumy* strata are best suited for construction of a cellar. But in reality, it is quite the opposite. Rock and other hard strata cost a good deal for excavation and cannot be kept dry easily on account of the joints or fissures in them. It is a different matter with soils.

The more clayey the soil, the better it is from the point of view of impermeability with respect to water.

The most economical and efficient method of constructing cellars is described below :—

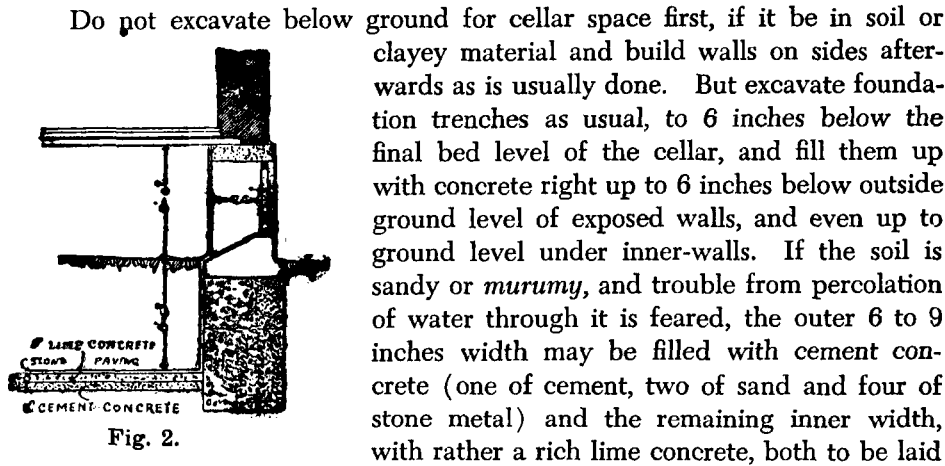

side by side in layers of 6 inches as shown in Fig. 2, and rammed well.

On the top of the concrete so laid, walls should be constructed with face masonry of stone or brick in mortar consisting of 4 parts of sand, one of cement, and  $\frac{1}{2}$  of lime and inside masonry as usual in lime mortar but a slightly larger proportion of lime in it, care should be taken that no hollows are left. This should be kept well watered for at least one week. Then the earth or *murum* in the cellar portion should be excavated to 6 inches below the required final level of the cellar. A layer of 6 inches of cement or at least 3 inches cement concrete at bottom and 3 inches of lime concrete above it, may be placed for flooring of the cellar, and the surface paved with slabs, if desired. When the ceiling is constructed, the inner sides of the concrete wall should be washed and dressed, where necessary, and plastered with a mixture of 4 parts of sand, one of cement and  $\frac{1}{2}$  of lime, with a final thin coat of fine sand and cement in equal proportions. The joints of the face masonry should be pointed with cement as usual. The floor should slope towards a small pit or sump. The cellars constructed in this manner may be depended upon for water-tightness.

For light and ventilation, a sufficient number of windows should be provided with their sills at least 9 inches above the ground surface. Shutters of very fine wire mesh are required to keep out vermin. The height of ceiling above floor should be at least 7 ft.

## Damp and How to Prevent it : III

Damp is dangerous in several ways. Firstly, it seriously affects the strength of walls, sometimes causing them to collapse, particularly if clay in some form or other is used in their construction—either partially in the form of mud mortar or wholly as sun-dried bricks, or even as burnt bricks. To what extent it does so will be clear from a very common instance. Everybody knows how hard and tough the dry clods of earth in a ploughed field are. Many of them will bear the full weight of a grown-up man standing upon them. But notice what happens when a slight rain drizzles over them. The clods in the entire field are at once reduced to powder, and lie flat on the ground.

It is common experience in villages that where damp has risen into the exposed walls, the earth in the exposed joints of stone or brick masonry, or on the surface of earth walls falls in powder at the slightest touch. This is due to the fact that the moisture rising from the bottom contains salts (mostly of sodium) and when the latter come in contact with the carbonic acid gas in the atmosphere, the earth loses coherence according to the chemical reaction explained in Appendix No. 1.

If the walls are of burnt brick masonry, the bricks absorb damp and with it, salts. The moisture evaporates and the salts are left behind in the brick. They cause the exposed surface of bricks to disintegrate and fall to powder. Thus, it is a common phenomenon, where damp has risen in brick masonry that in the lowermost one or two feet, the surface of the brick masonry is invariably seen to have worn out, leaving the upper surfaces to overhang a few inches. This is due to the above cause.

The effect of damp on health is still worse. It works out greatest mischief especially when it is present in close, dark rooms with inadequate means of renewing the air. Even in rooms with free circulation of air, damp alone is a source of danger ; it interferes with the natural evaporation from the skin surface of the human body; it carries the impurities in the air; and it maintains a low temperature. All these factors combined together, make the place unhealthy, even though actual disease germs may not be present. But when the rooms are close and dark, and free circulation of air is wanting, the danger is enormously increased. Damp causes organic matter to decompose, and the latter gives out poisonous gases, which diffuse into the air, when full of water vapour. The latter forms a breeding place for microbes of diseases and when inhaled they get a direct entrance into the human system to work mischief. This has a very deleterious effect upon infants and women who have to keep indoors for the most part of the day.

Malaria, neuralgia, acute and chronic rheumatism are the direct results. These diseases suck the life-blood and eat into the very vitality. The heavy toll of death on human life especially amongst infants and females by anæmia and consumption is the direct consequence of the presence of damp in ill-lighted and ill-ventilated, stuffy houses.

In spite of this, our people have lost a sense of fear about it, because they are so familiar with it. It is the commonest thing in villages, crowded towns, and in old-fashioned houses in cities with mud walls. The writer has specially visited a number of houses which Dame Superstition had denounced as haunted by evil spirits owing to the successive deaths which had occurred in them, and he invariably found them to have been ill-lighted, ill-ventilated and above all affected by damp to such an extent that it was most trying to stand there even for a few seconds breathing in the horribly smelling exhalations emanating from the mouldy surface of the walls and floors.

Is there no remedy? Is it not possible to fight and stamp out this diabolical evil of damp? Certainly it is. Only, you must have a strong will and a firm determination to do so. In this chapter, I propose to discuss how damp can be prevented and later on under 'Sanitation' point out remedies to eradicate it, where already existing.

There are many sources of damp, but the important ones are :—

- (1) Damp rising from the soil.
- (2) Damp descending from roof into walls.
- (3) Moisture driven by rain piercing through the external walls.

Damp rises from the ground in two ways. One, through the foundations and the other through adjacent ground surface touching or coming into contact with the material of which the walls are composed. The moisture absorbed by the wall from the base is comparatively very little. That entering the wall from the earth against the sides is considerable. The exact quantity depends upon the wetness of the side earth and the absorbing capacity of the materials of the wall.

One remedy to prevent this damp rising up the walls is to keep the plinth level higher than the ground surface surrounding it. Still the moisture absorbed by the lower portion of the wall may rise up by capillary attraction several feet and show itself by direct evidence of irregularly stained patches or mouldy surfaces.

Very often houses are built close together and the narrow space between them gets filled with earth or other debris which goes on accumulating and its top rises higher than the plinth level. The moisture from this is absorbed by the walls even though the plinth may have been kept high enough above the natural ground surface all round, when first built.

Another cause of damp rising from the ground is the waste water from sinks in the kitchen and especially from bath-rooms which, in many cases, is allowed to be absorbed in the ground, close to the houses. The obvious remedy for the latter is to convey it through a pipe or an open channel of a non-absorbent material to a distance of at least 15 or 20 ft. away from the house into a cement-lined underground cistern, lift it from the cistern, and distribute it daily over a large open ground, for evaporation by the sun. Small pails may be kept below pipes from the kitchen sink which should be similarly emptied every day. This will be treated in detail under 'Sanitation'.

For preventing damp rising from the ground, there are several remedies but the one which is cheap and efficient is to cut off the connection of the lower portion of the walls with the upper by interposing a course of some damp-proof material, a little above the ground level—preferably just below the plinth. Different materials might be found cheaply available at different places. Hence a few alternative suggestions are made here.

(1) Shahabad or other similar paving slabs of the full width of the walls should be laid in cement mortar all round. They should be at least 1½ in. thick—and very carefully evenly embedded to preclude the possibility of being broken. The joints should be filled with a rich mixture of cement mortar, say, one of cement to 3 of sand.

(2) About ¾ in. to 1 in. thick course of hot asphalt laid all round on top of plinth walls.

(3) A 3-inch course of cement concrete of the full width of walls.

(4) Two or three layers of slate laid in cement.

(5) A layer of sheet lead.

(6) A layer of glazed stone-ware bricks.

(7) A ¾ inch layer of cement concrete with coal-tar.

The last is very cheap and most suited for cottage building and is, therefore, specially recommended. A ¾ inch layer of cement concrete, (one of cement, 2 of sand and 4 of gravel) should be laid and kept moist for a day. The next morning hot coal-tar should be poured over it to form a uniform layer ¾ inch thick. Sand should be freely sprinkled on it, a day allowed to pass, the extra loose sand should be removed and then wall work commenced. This is not only damp-proof, but is also proof against white ants.

For preventing damp rising from the floor, if the latter is of *murum* or similar absorbent material, the best course is to spread a layer 6 in. thick of shingle of varying sizes, small and big, spread a little *murum*, say, about 2 inches thick above it, and on the top of it lay lime concrete at least 3 inches thick. Even if *murum* or mud floor is constructed instead of one of concrete, it remains dry.

The damp descending from the top of walls through leaky roofs can be prevented by constructing a leak-proof roof. It is comparatively an easy matter to construct a water-proof pitched or sloping roof, but where flat terraced roofs are constructed, parapets have necessarily to be built. These obstruct a free flow of water and cause it to soak through cracks into the walls below. Again, very often parapets are built at the end of sloping roofs both for decorative effect and for carrying rain water through down take pipes, which, if otherwise allowed to drop from a height of storeyed buildings, would scour out the road or ground surface. Under such circumstances, if special precautions are not taken, there is every possibility of damp soaking into the wall through hair cracks in the gutter behind the parapet. These problems are discussed later on under 'Roofing'.

Remedies for preventing moisture being forced by high winds through earth walls are discussed in a special chapter under the caption of water-proofing of exposed surface of earth walls.

Another source of damp is the use of materials of absorbent nature employed in building construction; e.g. porous bricks. Some bricks would absorb their own weight of water. Mortar, if it contains sea sand, would absorb moisture on account of the particles of salt present in it which have a considerable affinity for moisture. Such materials behave like a sponge. In dry weather, they get dried up but during wet weather again, they absorb moisture and become saturated with water.

In the case of mud walls or stone walls in mud-mortar, if the mud contains free salts, they absorb a large quantity of moisture from the air. The remedy is to leach or wash the salts out before use by a process similar to the one mentioned in Chapter I.

In short, if good shoes, in the form of a damp-proof course are used and a good hat in the form of a water-tight roof is provided, even walls built of sun-dried clay bricks or of even lumps of clay, will give perfect satisfaction in respect of damp. A coat in the form of some special water-proofing treatment, if provided, particularly in the case of earth walls, will prolong the life of the walls, but from the point of view of damp and its effects on health, rain water beating against walls is not so important.

Walls form by far the most important and costliest item on the estimate of a building and it is therefore, here, that some room for economy must be found. It can best be effected, as we have already seen, by using local materials. But certain materials available at a particular place may be scarce at another. Hence, it would be well to discuss the various alternative methods of wall construction with different materials. Before doing this we shall discuss the question of framed structure or load-bearing walls.

#### Framed Structure Versus Solid Walls

There has been a time-honoured practice of building walls, in India, in which the walls are reinforced by means of a framework of vertical posts and horizontal beams fixed on their tops and all embedded into the walls. In the houses of the rich, the wooden members of the framed structure used to be obtained from cut timber and therefore for the sake of decorative effect they were left projecting half an inch beyond the wall surface; while in the houses of the lower classes, they were either round rafters or roughly squared pieces of timber embedded in the centre of the walls. The object of the structure is to throw all the upper load of floors and roof over the posts, which are further strengthened by the lateral support they received from the walls. The walls, in this instance, have practically no structural function to perform, at least in the beginning, but to serve merely as partitions and to prevent transmission of heat or cold and sound from one side to the other, and also to afford protection from thieves. The fear of robbers weighed so much with the people of old times that though the walls were not primarily intended to take up the load above, they were built very thick, 3½ feet to 6 feet or even more in some cases. The extra thickness of the inner walls was utilised in most cases for a staircase which was accommodated in the body of such walls.

Apart from the numerous merits of this system of framed wall construction, which have been discussed in the author's treatise, *Build Your Own Home*, there is a great outstanding disadvantage in it, which at once eclipses all its merits. It is in the fact that the members of the frames, which consisted in old times of wood, were subject to the attack of dry rot\* and termites (white ants), the greatest enemies of wood in India. Dry rot works its mischief, as we have already seen, particularly in places which are damp and which have a deficiency of free air. Now, in situations where frames were used, either partially or fully buried in the walls, they could not get free air, and moreover,

---

\* Please see page 12.

the defective drainage arrangements to which these old houses were usually subject, also caused damp to rise. Thus rot first started in the bottom of the posts which gradually spread to the top and, ultimately, attacked the post plates also. The natural result of this defect was that in many cases the frame members having been hollowed out could no longer support the load, which consequently fell upon the walls. The secret of the long life of such old houses lay in the extraordinary thickness of the walls. If they were of ordinary thickness of 18 inches, they would certainly have crumbled down in a shorter period.

Thus a framed structure of wood should not commend itself to anybody unless either the walls are built of extra thickness, which, in these days of restrictions of space and funds, is not likely to find favour with people, or unless some such material like steel, proof against white ants and dry rot is substituted for wood of the frames. This sort of construction would do well for temporary sheds, farm-houses, barns, stables, cowsheds, etc., but not for permanent structures built as an investment.

From the point of view of economy also it may be noted that where special "white earth", which is generally used for preparing mud mortar for such walls either of stone or burnt brick, costs more than Rs. 10/- per 100 c.ft. including carting charges, this sort of construction even with round teak rafters for frames is more expensive than solid walls built in lime mortar.

It may be mentioned here, incidentally, that for a ground floor structure only, that is, for a house without any storey, if 18 inches thick walls in mud mortar are well founded and built perfectly in plumb no reinforcement of posts, etc., is required for supporting the load of the roof. If one or more storeys are to be constructed, the most economical and efficient method is to reinforce them by means of some sort of slender steel columns.

Tests made by the Bureau of Standards in America have conclusively proved that such columns, if rigidly fixed all round in the centre of the walls so as to prevent any bending or buckling, can be counted on to carry loads up to the yield point of steel before failure occurs. The columns may be in the form of either galvanised iron pipes, of say, 1½ inches diameter, filled with cement concrete, with wall-plates also of the same connected to them with T-pieces, or even better still, I-beams of the lightest section, viz. 4 in. × 1¼ in. weighing 5 lbs. per foot of length, with cement concrete filled between the flanges. At the controlled rate of Rs. 18/- per cwt. the above I-beams cost seven annas per foot and if five annas are added to it for the cement concrete and labour of joining and fixing, the aggregate rate of twelve annas per foot length compares favourably even with round rafters of timbers and is absolutely free from the danger to which wood is liable.\*

---

\* On account of the enormous increase in cost of steel these two methods have lost their advantage of economy.

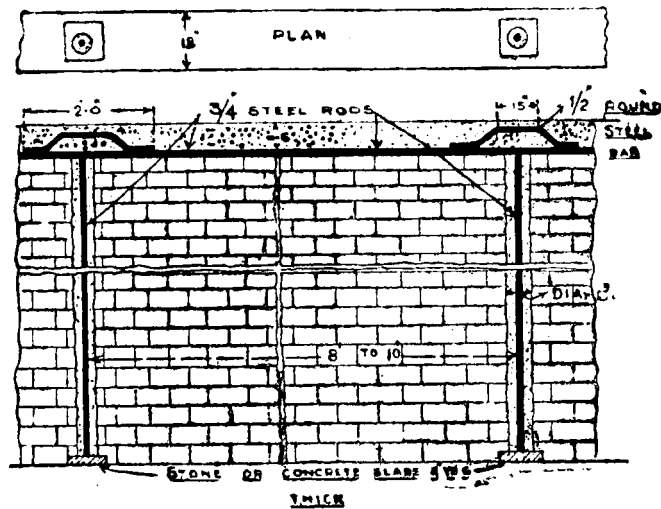

Figs. 3 &amp; 4.

It is possible to make it cheaper still if the following method is adopted :—

Instead of wooden posts and post-plates above them, erect  $\frac{1}{2}$  inch round bars of the necessary height with bottom placed on concrete or stone slabs, at least 4 inches thick and 12 inches  $\times$  12 inches in length and breadth. Tie on their top another horizontal bar of the same thickness and another small piece bent as shown in the sketch, (Figs. 3 and 4) 4 inches above it, by means of a piece of thin wire. After this is done, regular wall of stone or burnt brick in mud may be commenced, leaving in each layer an irregular hollow space of, say, some 6 inches diameter all round the iron rod and fill it up each time, when 4 layers of brick work or about 12 to 15 in. of stone work is built, with cement concrete. The objects of this are: (1) to protect the steel against rusting; (2) to give it the necessary stiffness against bending or buckling; and (3) to form, in other words, a reinforced cement concrete pillar and beam at top, without centering. When work is commenced the next day, the concrete surface of the previous day should be roughened before fresh concrete is added. The vertical rod can be lengthened by tying two ends of rod with an overlap of 24 inches by a wire. When the level of about two inches below the horizontal rod is reached, the edges of the wall may be lined with bricks laid flat, or stones, and a hollow space of 6 inches width may be left with the horizontal rod at the top in the centre. The rod should be placed that there will be a hollow space of two inches below it. This and the space above it may be similarly filled with cement concrete so as to form a rough concrete beam of 7 or 8 inches thickness and of the same width.

With the foregoing discussion about framed structures we now turn to the subject of walls.

The materials forming the composition of walls are of two sorts : one is called the aggregate, such as stones, bricks, etc., and the other is called the binding or cementing material, like mortar. The latter may consist of lime, cement or mud.

In an earlier chapter, while discussing materials, mud mortar was advocated as a suitable material for walls of houses of the cottage type. But while using it, certain precautions have to be taken, as otherwise, not only will the bill for the maintenance and annual repairs of the building swell enormously, but the life of the building would be shortened. These are : (1) Proper selection of the earth; (2) Guarding against damp or any sort of moisture entering the walls; and (2) Protection against rats and white ants.

The third precaution, viz. protection from rats burrowing under walls, and white ants eating out timber used in the structure, has been treated in Chapter V of this book.

### 1. Walls of Stone.

After a general discussion on framed structure *versus* solid wall we shall consider the different methods of building walls with whatever material available locally. Stone and brick are the most common materials. If stone is used there are two methods of building walls; one, which is called the coursed rubble, requiring faces of stones to be dressed to a rectangular shape. In this, the face of the wall has long lines of horizontal joints, with all the vertical joints at right angles to them. This sort of construction is pretty expensive. The other sort presents irregular joints in the face work and is called uncoursed rubble masonry, because there are no regular courses in it. This is not only comparatively cheaper but also looks artistic if properly done.

With the use of mud as the cementing material, every little point which tends to make the wall strong, cannot be neglected. Hence, it would not be amiss to point out, in passing, the common mistakes made in practice and the necessary precautions required to avoid them in the above two methods of stone walls.

The first precaution is the use on a generous scale of through stones or "headers" as they are called, that is, stones with their length equal to the full thickness of the wall. Their function is to bind the two faces of the wall together. They should be spaced, in each course defined by the corners, at intervals of 6 feet. When the corner stones for a course are fixed at the two ends of the wall, the headers for that course should be first placed in their positions and then the intermediate spaces between them should be filled with masonry. The headers in the course above it should be so fixed that each comes midway between the two in the immediately upper and lower courses.

If the headers of the full thickness of the wall are costly, two shorter ones should be so fixed, side by side, with their faces on the opposite sides of the walls as shown in plan and section in Figs. 5 and 6 at H H, that their tails overlap at least 6 inches as shown in the sketch.

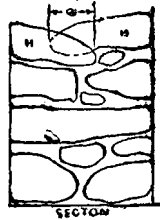

Figs. 5 &amp; 6

up the work thereby. But this is a dangerous practice, though the face of the wall apparently looks more elegant. Even common sense will tell us that stones which have no sufficient base to rest upon, nor tail going into the thickness of the wall to bind it are likely to slip away under pressure from above. In this connection the general rule is that *every stone used in the face work of wall must have a tail at least  $1\frac{1}{4}$  times its height.*

The third necessary safeguard is that not only should there be no hollow spaces left in the wall, but that every hollow must be filled, not with mud alone, but with stones set hard in the mud under a stroke of hammer. Again, instead of a number of small stones or chips, it is better, in the interest of strength and stability, to select large stones to suit the shape of the hollow.

(Small stones, whether in the face work or hearting of walls, mean more joints and more mortar. This increases the cost and also weakens the structure.)

## 2. Burnt Brick Walls

The quality of bricks manufactured in India, except perhaps in a few places, is poor. Especially, their skin being not so hard and non-absorbent, like that of English bricks, they absorb a good deal of moisture and become damp. To overcome these defects, the brickwork is generally plastered with either lime or cement which increases its cost. If the annual average rainfall of a place is above 50 inches, some water-proofing treatment is necessary to keep out damp, but at other places, if only well burnt, and uniformly coloured bricks are selected for the face work and they are laid perfectly in plumb, the work, if neatly pointed, is lasting and looks quite well, even without plaster. If the experience of one monsoon shows that it affords a sufficient protection from damp, as will generally be found to be the case at such places of low rainfall,

there will be a considerable saving in the cost of external plaster. If necessary a coat or wash of cement and fine sand in equal proportions, mixed with water and applied with a brush makes the surface reasonably water-resistant.

### 3. Hollow Concrete Walls

Cement concrete as a cheap building material is a modern product. Great strides have been made, of late, in using it successfully even in the extreme ranges of temperature in the tropics. As it possesses considerable strength, economy can be effected by adopting a thinner section of wall. But in a hot country like India, as a thin wall is likely to make the house hot, a wall thinner than 9 inches in width cannot be used, especially where exposed to sun. However, as the material is pliable when wet, hollow concrete blocks can be made. (A wall built of these, affords protection from heat on account of the air space inside it. In towns and villages, served by a railway line or a good metalled road bearing motor traffic, cement concrete for cottage construction lends special charm, as clean river sand and gravel could be obtained in plenty, in the greater part of India, merely for the charges of collecting. Such buildings are not only strong and durable, but are easy and cheap to maintain, keep clean, and look neat and tidy. The only difficulty is of getting machines for moulding hollow blocks on a cheap hire so as to come within the reach of a house-builder of ordinary means. On account of this difficulty, its use has been at present restricted to buildings of considerable magnitude only, in which concrete blocks are required to be manufactured on a large scale. However, concrete as a cheap material has great potential future before it in India.

### 4. Combination of Burnt and Unburnt Brick

There are many places where stone quarries are not within a reasonable distance and bricks from kilns which are almost entirely burnt by village potters may also have to be carted from a distant village or a small town. At such places, a composite work of a combination of burnt and unburnt bricks may be resorted to.

The idea is to use burnt bricks only on the exposed surface of walls for making them resist the atmospheric influences, and sun-dried or *kacha* bricks not only for inner partitions but also on the inner face of the exposed walls. A further economy in this respect may be made by using clay lumps, instead of regular sun-dried bricks. The process of preparing them is described below :—

Get a heap of white earth or whatever soil that may be available on the site, remove all roots of vegetation, etc., sift it through a screen of  $\frac{3}{4}$  inch mesh. If it contains an undue amount of clay and shows a tendency to crack while

H-3.

drying, mix some sand or gravel with it and make a plastic mass of it with water of such a consistency that a lump made in hand, if placed on ground, will not spread. Then on a levelled piece of ground sprinkle some sand or dry earth or ashes and form a roll of it 10 feet or longer as the space will permit, 13 inches wide and 5 to 6 inches thick, roughly squared either by hand or a flat piece of wood, and cut it across into pieces,  $8\frac{1}{2}$  inches long, by passing a piece of wire vertically down across it by hand from top to bottom. Thus each piece will be roughly 13 in. by  $8\frac{1}{2}$  in. by 5 to 6 in. thick. The thickness will depend upon the thickness of the burnt brick used in the face work. It should be twice their thickness plus  $\frac{1}{2}$  in. Thus if the burnt bricks available are  $2\frac{1}{2}$  in. thick, the thickness of this lump should be  $5\frac{1}{2}$  in. and so on. One such piece is shown in Fig. 7.

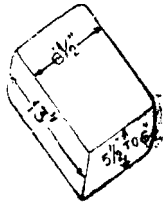

Fig. 7.

Allow these pieces to dry in the sun for two days, then turn them over for drying for one more day, after which, they are ready for use in the wall. The method of constructing the walls is as follows :—

A number of well-burnt bricks should be kept immersed in water for 2 or 3 hours before starting the work. Two masons should be employed, one with these burnt bricks and lime mortar on the outside face of the wall to be built, and the other, with the clay lumps and mud mortar on the inner. The mason on the outside should spread a layer of lime mortar of  $\frac{1}{2}$  inch thickness, and  $4\frac{1}{2}$  in. width along the exposed or outer edge of the wall and behind that the other mason should spread mud mortar of the same thickness and of width up to the inner edge of the wall, then the first mason sitting outside should lay bricks stretcher-wise; i.e. parallel to the wall as shown in the Fig. 8 leaving a space of  $\frac{1}{2}$  inch between the ends of bricks, they will of course rest on lime mortar. The half inch space between the bricks should be filled with lime

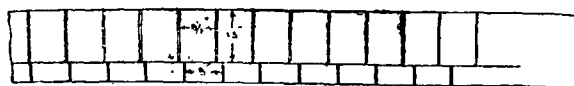

Fig. 8—First course of burnt brick in plan.

mortar. While this is being done, the second mason on the inside should lay the clay lumps headerwise, i.e. with their 13 in. side across the wall, as shown in Fig. 8, making a joint of  $\frac{1}{2}$  in. thickness with both the burnt bricks already laid and with another clay lump, laid by its side, filling it with mud mortar.

For the second course of burnt bricks, the first mason should spread another layer  $\frac{1}{2}$  in. thick and  $4\frac{1}{2}$  in. wide, of lime mortar, as before, on the top of the layer previously laid, and lay bricks stretcher-wise as before but breaking joints in the centre of the bricks previously laid as shown in Fig. 9. The second

mason should fill in the joint between this layer and the clay lump already laid, with mud mortar. This completes one course of the clay lump. As the thickness of clay lumps is twice that of the burnt brick plus  $\frac{1}{2}$  inch, the top of the wall at this stage will be roughly level.



Fig. 9—Second course of burnt bricks in plan.

The first mason should then spread another layer of lime mortar  $\frac{1}{2}$  inch thick and  $4\frac{1}{2}$  in. wide as before on the top of the burnt bricks and lay bricks near the outer edge headerwise, i.e. 9 in. length across the wall as in Fig. 10, making a vertical joint  $\frac{1}{2}$  inch thick between two bricks; on the top of this

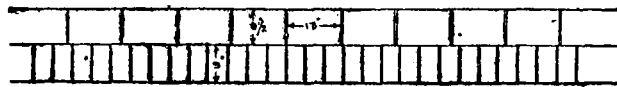

Fig. 10—Third course of burnt brick and second of clay lumps in plan.

another layer of lime mortar to be spread as before and another course of bricks laid headerwise as before, as shown in Fig. 11 but with joints coming exactly over the centre of the bricks below. The front portion of these bricks  $4\frac{1}{2}$  in. long will be laid in lime mortar, the remaining  $4\frac{1}{2}$ '' portion being laid

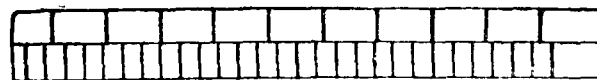
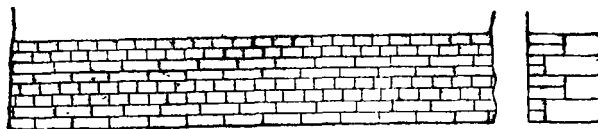

Fig. 11—Fourth course of burnt bricks and second of clay lumps in plan.

in mud. The inner mason should lay lumps stretcher-wise, i.e. 13 inches length parallel to the length of the wall as shown in Figs. 10 and 11, taking care to bring the front surface in plumb and filling joints of bed and the side well with mud.

After this, two stretcher courses of burnt bricks on the outside in  $4\frac{1}{2}$  inch width of lime mortar and a header course of clay lumps behind it laid in mud are to be repeated and so on.



Figs. 12, 13—Front elevation and section.

How the outside surface of such a wall will appear is shown in Fig. 12 and a cross section of it in Fig. 13.

The points to be specially noted in this sort of construction are :—

(1) The mud mortar should contain a little more sand than usual and it should be used a little stiff, i.e. just sufficiently wet as would enable it to be thrust into the joints with a mason's trowel. These precautions are necessary because we have to join mud work with lime mortar work. Mud mortar shrinks more than lime mortar. If the mud mortar contains more water, it will shrink more and a crack will be formed at the junction of both the mortars. Admixture of some sand and use of as little water as possible in the mud mortar, would cause it to shrink less. The object to be aimed at is to make the coefficient of shrinkage of both the mortars equal. This may be tried by an experiment and, if required, the lime mortar may be made slightly more wet. It is for this reason, necessary, that the burnt bricks must be kept well immersed in water for a sufficiently long time before being used. Otherwise, they would absorb moisture from the lime mortar and affect its coefficient of shrinkage.

(2) The mason using lime mortar should be made to take special care in filling the joints neatly, i.e. making them of uniform width, and making the horizontal joints exactly at right angles to the vertical, while laying the masonry in the first instance, so that there should be no necessity of pointing them again.

(3) Water should be sprinkled freely on the brick face to help lime mortar set hard. It should not, however, be done on the top of the wall but on the exposed face only, because the water on the top might enter the mud mortar or clay lumps and thus damage the wall.

(4) If the foundations are sufficiently sound, it is not necessary to reinforce the wall with posts, etc., if the building has no storey. 18 in. thick walls constructed in the above manner will easily sustain the weight of the roof.

(5) There is no need of plastering the inner surface of walls if it is made plumb and smooth, just while laying the clay lumps, by dressing the projecting portion with a mason's axe and applying mud mortar mixed with a little cow-dung in the hollows.

(6) The inner surface, thus prepared, should then be given a wash with a mixture of 12 parts of white earth, two of cow-dung and one part of cement, and may then be treated with two coats of white-wash, after the surface has dried.

(7) Lintels over doors and windows should go a little longer, say, 9 inches at least into the wall on both sides of the opening.

(8) It is desirable to use burnt brick and lime mortar on the sides of door and window openings.

(9) If a water-tight roof, say, such as that of corrugated iron sheets or asbestos cement sheets is constructed, the house with walls as above looks like a *pucca* structure and does really behave like one.

### 5. Walls of Earth

Earth walling is of great antiquity in India. Even to this day, it is the common practice in villages and towns in every part of the country. Recently it has been gradually falling into disuse, particularly in towns, perhaps on account of improved facilities of transport.

Earth is specially well adapted for walling in country districts away from large towns where a suitable variety of it is available in plenty merely for the collecting, where skilled labour is costly and unskilled labour cheap, and where site is not much restricted, i.e. work of rather a bulky nature is not only admissible, but would rather conform to the general surroundings.

If earth walling is adopted, it is necessary to modify the design to a certain extent as given below :—

- (1) The exterior angles of corners should be rounded.
- (2) Projections and recesses in walls should be avoided. Bays and angle nooks are unsuited to earth walls.
- (3) As far as possible walls up to the plinth level should be built of stone or burnt brick; but if a good slope away from the walls is given rapidly, there is no harm if the plinth is also of earth.
- (4) Jambs (i.e., sides) of doors and windows should be preferably lined with burnt brick in lime. This is not quite necessary, but these are the parts very much subjected to wear.
- (5) The eaves of the roof should project a little longer than usual, so that the top portion of the walls is protected from rain.
- (6) Water-tight shoes and hats, i.e. foundation of non-absorbing material and a non-leaking roof should be provided.

Earth, as a material for wall, really possesses a good many virtues to commend itself for more general acceptance. The special advantages which it commands over the stone or brick are given below :—

- (1) It is the cheapest and easiest form of walling. Stone costs something for quarrying, carting and dressing; brick costs something for moulding, burning and transport. Earth alone is the only material which can be dug near the site and used directly into the fabric of walls without any elaborate or costly process of conversion.
- (2) An earth wall can be built by an unskilled labourer or farmer. For stone or brick walls one has to depend upon high-paid masons and other men of the artisan class.
- (3) Earth being a far better insulator of heat, houses of earth walls keep cool in summer and retain warmth in winter. Hence they are found to be more comfortable. Besides, as constructing a slightly thicker wall of earth

costs only a trifle more, it is within the easy reach of the poor, to secure greater comfort at a little extra cost.

(4) The repairs and renewals are very easy and cost very little, e.g. mud plaster can be cheaply and easily renewed. Lime mortar does not stick so well to old mortar which has already set. This is not the case with earth. Again, if brickwork is dismantled, there is some loss of bricks in breakage. If, however, an earth wall is dismantled, nothing is lost.

(5) The progress of the work can be speeded up to any extent.

(6) They are far less susceptible to destruction by an earthquake than either stone or brick walls, as was proved in the earthquake of 1934 in Bihar. This is a very important discovery and this fact has been borne in mind in the reconstruction of Bihar.

(7) As the material from the immediate surrounding locality, is used, earthen walls conform to the harmony of the neighbourhood.

(8) Earth walls are more secure from fire than stone walls. Stone, when subjected to heat for a long time, cracks and splinters.

There are four methods of earth walling :

- (a) Walls with sundried bricks.
- (b) Walls built with mud *in situ*.
- (c) *Pise de terre*, or walls of rammed moist earth.
- (d) Stabilised soil walls.

The first is very common even to this day in towns and villages. This form of walling is extensively used for internal partitions. The second method was once very much in vogue, but has almost died out at present, though its rude technique is found to have been still preserved by poor farmers in remote villages. The third is almost unknown in India though it has many merits to commend itself for general adoption by middle and lower class people. It has been very extensively practised in western countries in spite of great natural disabilities obtaining there, such as the absence of dry weather and hot sun. The fourth is a recent one developed after research, and is cheap and very satisfactory under certain favourable conditions.

#### 5(a). Walls of Sun-dried Kacha Bricks.

The reason why this method is more popular than the other method is the convenience and ease with which it can be worked. First of all, the *kacha*, bricks can be moulded at leisure, dried and kept ready, and work commenced at any convenient time later on. Secondly, walls of any desired thickness can be built according to the size of the bricks moulded, and thirdly,

the plastering or giving a wash of white earth and cowdung can be taken in hand later at some convenient date. The only important thing is that all the operations must be done before the rainy season begins. If the bricks are ready, actual building work does not require much time.

Any soil would be suitable. Of course, white or impervious earth described on page 14 is the best. But if either of these is not obtainable on site, any other soil would serve the purpose, provided the bricks formed of it do not crack much during the drying process. In that case, some sand or, better still, fine *murum* (crushed disintegrated rock) should be mixed with it. If the structure is single-storied, 18 inch-thick walls can easily take up the load of the roof and resist wind pressure, without any reinforcement of vertical wooden or other posts. For a two-storied building, the thickness should be 21 inches throughout for both the floors, if reinforcing posts are not used. If space permits, thicker walls like this are preferable, both from the point of view of cost and protection from heat, to walls of a thickness of 18 inches or less, even if reinforced with posts. For, unless well-seasoned cut teak posts are used they are liable to be attacked by white ants or to disintegrate by dry rot. For a two-storied building, a thickness of 21 inches *throughout* is recommended because, if the walls of the upper storey are made 18 inches thick and flush with the outer edge of the lower walls, i.e. if an offset of 3 inches is left on the inner side, the centre of gravity falls towards the outside and the walls are likely to tilt on that side, if the foundations are not good. If, on the other hand, the upper walls are built in the centre leaving equal offset of 1½ inches on either side, the rain-water striking the outer surface is likely to soak through the outer offset.

It is possible to make this sort of walling still cheaper by using earth lumps described in the previous chapter instead of regularly moulded bricks.

#### 5(b) Mud walls built in Situ or "Cobwork."

Once a very common method of wall construction, it has now almost died out in this country. It is still seen practised in some remote villages by indigent people. They take one or two days 'off' from their farm work and men, women and children—members of the entire family concentrate together and build a hut for themselves, because they cannot afford to employ the services either of a skilled artisan or even of a slightly skilled fellow farmer. Again, the whole aim is to finish the work in a minimum period to save time for field work. They are, therefore, content if the hut just gives the family a shelter from the inclemency of weather. Hence, no attempt is made for obtaining uniform thickness of the wall; or, to test the surface with a plumb baub. The wall may therefore be crooked and tapering towards the top. It is built simply by piling lumps or balls of mud one upon the other and wiping the surface smooth by hand dipped into water. No attempt is made to build the walls solidly on a sound footing; hence they begin to crack soon after-

wards. The hut is invariably covered with a thatching of hay, paddy straw or even leaves of palm trees, of inadequate thickness, with the result that rain-water soaks into them, and as there is generally no plinth provided, damp also rises from the bottom. Thus the whole thing presents an appearance of neglect and squalor.

Mud, however, forms an excellent material for construction, the virtues of which are not put to a proper test and appreciated in these days. Our forefathers knew the secret of construction very well. We see old neglected forts or ramparts 30 to 40 feet high still enduring, though in a ruinous condition, encircling villages or towns built formerly for protection from enemy's attacks in those troublous times. They used stones for the faces up to a certain height, and rammed mud between them for the hearting, and above this height, mud appears to have been used even on the faces. Years, amounting to two or three centuries, have rolled on, they have never received any care of repairs at human hands, but on the contrary every neglect and contempt, still they stand obdurate all these years in defiance of the fury of Nature ; what more triumph can there be of the enduring power of cobwork ?

To quote another instance, the famous fort of Bharatpur near Agra, one of the most invulnerable strongholds of the Jats in India at that time, was built entirely in mud. It was several times besieged by the British and bombarded with heavy guns on several occasions ; but without success, so much so, that this led to the establishment of a superstition to be associated with it, that as angels protected the fort, it was not possible for any human effort on earth to capture it. At last it was when a strong contingent of army, under Lord Combermere, was despatched and only when an extraordinarily heavy mine of gun powder, on a scale thereto unknown, was applied at the bottom and fired, that a piece of the rampart was bodily lifted with men on it and hurled into the sky. And through the passage made by it the British troops made their entry and captured the fort in 1826.

The Jat king constructed the bulwark of mud in preference to stone, not because stone was scarce or because he could not afford it, but because he knew confidently that a mud fort was stronger than one of stone and the result proved that he was justified in his belief.

There is considerable evidence to show that this form of wall construction was once very common in domestic buildings but somehow or other, it came to be forgotten and now it is almost extinct. The correct process of doing it is described below :—

The foundations should be first excavated up to *murum* or rock, if the latter be found within a reasonable depth below the ground surface, or to a firm soil (except deep black cotton soil, which requires special treatment) and the trenches should be filled with boulders of stone, rubble, or burnt brick, if

stone is not within a reasonable distance ; mud mortar may safely be used. It is advisable to use stone or burnt brick upto the plinth.

The ground from which earth for preparing cob is to be utilised should be cleared of all vegetation, the upper 9 inches layer of it, which is full of roots of vegetation, decayed matter, etc., should be removed and the stratum below it should be excavated and used. All lumps should be broken. The more impervious the earth is to water, and free from swelling when wet and from cracking when dry again, the better it is for cobwork. It is screened to exclude stones above one inch in diameter. A circular heap is made of it with a hollow made in the centre at top which is filled with water and kept in that state for several days for "souring" Then wheat or rice straw, chopped into pieces 3 to 6 inches long, is sprinkled over it freely and the wet earth is drawn by a *phaorah* and mixed, while a man is sprinkling more water over it by means of the rose of a water-can. It is then well kneaded under the feet of workmen and thoroughly mixed into a suitable consistency. Some people mix dung from horse stables in it.

Lumps or balls of the cob are then formed which should be just wet enough to afford ease in laying; if they contain more water, they have a tendency to spread and the wall bulges out.

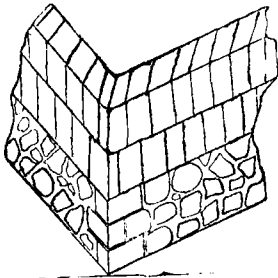
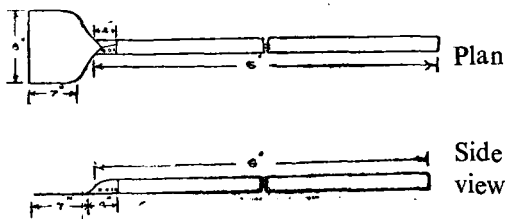

Fig. 14.

Diagonal layers, instead of horizontal ones, laid as shown in Fig. 14 are stronger. Each layer is trodden under the feet by the man who stands on the top of it. In most cases, shuttering of boards to support sides are not used, but the extra earth on the wall surface is pared or dressed after 24 hours, with an instrument having an iron edge to which is

attached a long wooden handle. (See Figs. 15 and 16.) A plumb line should



Figs. 15 & 16—Paring instrument.

be used at this time to make the faces truly vertical. If the lowermost one or two feet, or say, the plinth masonry on the outer face is constructed of either stone or burnt brick in mud, (which is strongly recommended in the interest of keeping the walls free from damp), it is very easy to keep the rest

of the upper surface of cobwork in plumb with this. Each course is 12 to 18 inches thick and is laid between horizontal strings stretched on both sides of the wall. As each layer is being laid, it is trodden by the man standing on top of the wall and receiving the balls of cob. Since very little water is used in the preparation of the balls of the cob—just so much in fact as would give

the necessary pliability to the material for ease of work—each layer dries up sufficiently to take up the weight of another above it in about an hour or two in this country, if the work is done in summer.

The thickness of the wall depends upon the height to which it is to be raised. For a single-storied building 21 to 25 inches thickness is sufficient both from the point of view of its own stability, strength for supporting weight of the roof, and protection from heat and cold. The internal partitions are best made of unburnt brick 9 to 18 inches thick, to save space. In Europe even two-storied houses of cob walls, *without* intermediate supporting wooden posts have been constructed and have stood well for over hundred years in spite of the wet weather which prevails there for almost 12 months in the year.

As the work progresses and the wall reaches a height not easily accessible to labourers for handing lumps of balls to the men standing above, a sort of tool consisting of an iron fork with a wooden handle as shown in the sketch (see Figs. 17 and 18) is used for reaching the balls to the man above. The surface of the wall constructed is pared or dressed and made smooth and plumb after 24 hours. It is then given a wash on the inside and outside of white earth mixed with a certain proportion of cow-dung.

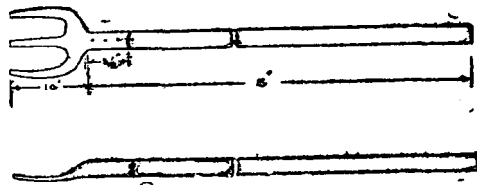

Figs. 17 & 18—Plan and side view of the fork.

There are two methods of making door and window openings. In one, the frames of doors or windows are erected in position by supporting them temporarily with inclined stays, when the wall work reaches their bottom level and the wall built between them as usual. In the other method, wall is first built solid with only the lintels fixed at the proper levels in it and afterwards the recesses for doors and windows are carved through below them, and frames inserted in them. The second method affords ease in construction, but as frames cannot be fixed by means of iron holdfasts, well anchored in the body of the wall, they are likely to be a little shaky in course of time. All outside corners should be widely rounded, so that they may present a neat appearance and may not be easily knocked off. The corners of door and window openings should be chamfered as usual.

**Roof** :—A hipped roof is more suited to this sort of construction as the walls need not be raised so high as in the case of gables. Again, the latter expose greater unprotected surface to rain.

On the top of a door, window or cupboard opening, lintels of wood, or if, trouble from white ants is feared, of R. C. C., may be placed. The point to be remembered is that they should be sufficiently long, projecting at least one foot over either corner.

Any roof covering may be used, provided it is water-tight. In this respect, a roof of corrugated iron sheets, with sheets bolted to wooden wall-plates on top of walls, is excellent. For preventing iron sheets being blown away by high wind, the wooden wall-plates may be fastened down by means of wire ropes, well anchored into the walls. A thatched roof looks more in harmony with cob walls, but firstly, it is insanitary, and again, it affords a breeding place for rats, and moreover, is likely to catch fire, and lastly, if not well cared for and repaired from time to time, it is likely to leak. The C. I. sheets may be covered with thatch, if desired, as it will serve to keep off heat effectually.

The mode of water-proofing the outside surface of earth walls in general has been discussed at the end of this chapter.

### 5(c) Pise de Terre

'*Pise de terre*' is a French expression for "rammed earth." This method of construction does not appear to have been practised in India. It is however an excellent and cheap method and most suited to Indian conditions. Hence, it has been treated at considerable length in the following few pages. The author has experimented on it on a small scale and found the results most promising.

Nothing would be better than to quote Mr. St. Loe Strachey, an authority on *Pise* building.

"As we do not possess the crystal air and intense sun heat of Australia, the earth walls do not harden in England."

We, in India, are very fortunate in possessing the advantage of both these "crystal air and intense sun heat."

To proceed with the quotation, "That heat evidently produces a skin, which must be almost like brick. At the same time, even in our English climate, the eighteen inch wall becomes perfectly strong and substantial for all practical purposes. As however it had to face the rains of an English autumn and winter, I have had the outside covered with a mixture of coal-tar and pitch, which produced a surface very much like that of a tarred road on end, and is quite satisfactory. On the inside of the building, the face is left untouched and has already become very dry and hard. It is evident that it will make a peculiarly good wall for a house"

There is a very interesting account given of *pise* church written by Abraham Reed, D.D., F.R.S.F., L.S. in Volume XXVII of the Cyclopædia or Universal Dictionary of Arts, Sciences and Literature from which is extracted the following quotation about a *pise* church :

"The Church was the most remarkable in this style of building; it is about 80 feet long, 40 feet broad, and 50 feet high; the walls built in *pise*

18 inches\* thick and crepe or roughcast on the outside with lime and sand. Soon after my arrival, the Church, by some accident, was destroyed by fire and remained unroofed for about twelve months, exposed to rains and frost. As it was suspected that the walls had sustained much damage, either by fire or the inclemency of the season and might fall down, it was determined to throw them down partially and leave only the lower parts standing; but even this was not done without much difficulty, such was the firmness and hardness the walls had acquired, the Church having stood for over *eighty years*, and all the repairs were only to give it on the outside, every twelve or fifteen years, a new coating of roughcast."

The essential difference between cobwork and *pise* work is that whereas in the former, mud is prepared with a free use of water and straw is added to it, in the latter, the earth which is just moist is rammed between boards or planks laid on both sides of the wall, and not only no straw is added to it but every bit of root of vegetation is scrupulously picked up and thrown away from it. Another difference is that cobwork, on account of its plastic condition, does not admit of ramming hard, while the success of *pise* work lies in quick and hard beating of the earth in moulds.

**Suitable Soils** :—Soils are sometimes called stiff or light from an agricultural point of view, according as they offer greater or less resistance to the plough. The stiffness is due to the greater proportion of clay, and the lightness, due to that of sand. The soil suitable for wall work should neither be heavy nor light. Between these two extremes there is a very wide range of soils which are suitable. The soils at these extremes also can be made suitable by blending them together in proper proportions. But as soon as complications of this nature enter, the *pise* work loses its greatest virtue of cheapness, because, one of the two soils has to be transported at considerable expense and also the cost of labour in the process of mixing the two together, has to be added to it.

Fine silt in the river bank is eminently suitable, so also silt from canals or tank beds.

Soil denuded every year by rain from hill-slopes and deposited at the foot is very good.

All earths which are suitable for brick or tiles, form an excellent material for *pise*. Thus between the excessively heavy on the one hand and the excessively light on the other, there is a countless variety of soils which are suitable. Of course, some of them are better than the others.

---

\* *N.B.*. The 18 inches walls were carried to 50 feet height without any vertical post to reinforce them.

Before deciding upon the final choice of a particular soil for work, it would be well if the following simple experiment be made.

Dig a pit in ground, say, about 3 feet by 3 feet and 18 inches deep. Then take a bottomless iron bucket of ordinary size and put it in the centre of the pit on a piece of stone slab or a wooden plank. Put the earth selected for the *pise* work into the bucket to form a layer of 4 inches in loose state; also put the other earth excavated from the pit round the bucket to form a layer of equal thickness. Ram both the earths hard until the layer is reduced to half its thickness. Then add on its top, layers of similar thickness, taking care to consolidate each before another is added; continue this till the top of the bucket is reached. Let it remain in that condition for 24 hours, after which, dig out the earth in the pit outside the bucket, till the latter with the lump of earth inside it can be lifted up. Take the bucket out and make it topsy turvy on ground, with the broad mouth down. Hold only the bucket now in hand and lift it up so that it comes off leaving the lump of earth on the ground. Protect its top by means of a slab or a piece of board from rain, if any is likely to fall, otherwise let it be exposed to sun and wind quite freely. If it does not crack, but goes on hardening every day as it dries up, the soil may be taken as quite suitable. If, on the other hand, it forms small cracks, it needs sand or some light soil to be mixed with it. This should be done and the exact proportions determined.

Another test is to make balls of earth with or without mixture of sand and watch their behaviour in respect of cracking and hardening. The mixture which gives the best results may be employed in the bucket lump test mentioned above.

**Foundations and Plinth** :—The foundations should be like those usually made for the burnt brick masonry. It is desirable to use stone for foundations and plinth, and if stone be scarce or costly, then burnt brick. This is necessary to protect the *pise* work from the splashes of rain-water dropping from eaves, or streams of storm water scouring the bottom. If lime is cheap, brick or stone in lime mortar may be used up to the plinth. This will ensure a dry bottom for the *pise* walls and, further, besides increasing their strength and longevity, afford protection from the inroads of rats and especially bandicoots which have a nasty habit of digging out heaps of earth from below the walls.

The site from which earth for the *pise* work is to be obtained should be excavated to a depth of 9 inches and all the stuff dug out, removed, and thrown away, as it is bound to contain roots of vegetation which are to be scrupulously excluded from the *pise* work. The soil below it should be excavated and all lumps broken by means of a wooden handle. Stones and pebbles above the size of one inch should also be picked out.

**Moisture** :—The correct degree of moisture is a very important factor. In most cases the soil at this depth below the ground surface, if used fresh, will contain sufficient moisture. The test of the correct quantity of moisture is that the soil should neither jump under the stroke of the rammer nor stick to its bottom. 8 to 15 p. c. of moisture is found to give the best results. If the earth contains but slightly more moisture than that necessary for good consolidation, the mass of earth below the rammer becomes elastic and deadens the effect of ramming; and though the surface sinks below the rammer, it rises up elsewhere. Thus, a little too dry and little too wet earths are both bad, though a little too dry is a lesser evil. It should be just moist enough to be crumbly and yet adhesive enough to retain the impression of fingers when pressed in hand.

**Boxing or Shuttering** :—When the earth of the proper consistency is prepared, boxes are placed in position. For economy and good workmanship, properly designed boxes are necessary. The chief desiderata of good boxes are : (1) They must be of such wood as will not swell under the action of moisture, nor warp, nor buckle under the pressure of ramming. (2) They must admit of easy fixing and removing, and still be rigid enough to stand true and square under the heaviest ramming. (3) The space between the two sides of shuttering must be as little obstructed as possible. (4) There must be an arrangement for putting stops for doors and window openings. (5) The tie rods must admit of easy removal without injury to the work already done. (6) The corners, in particular, must be very rigid. (7) The entire mechanism must be light, simple, easily repairable and fool-proof.

Deal wood boards,  $1\frac{1}{2}$  inches thick, serve the purpose best. There is a lot of scope for the inventive brain to design and perfect a form of boxing

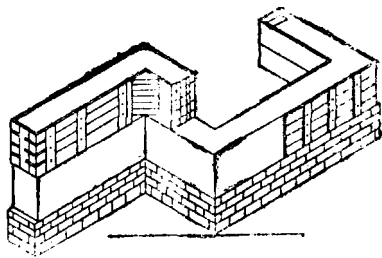

Fig. 19 showing how shuttering is fixed. The plinth is of burnt bricks. Boxing has been laid in position above it on the right-hand side for the first course, and on the left-hand side for the second course.

which would satisfy the needs under the severe climatic conditions of India. A type of boxing which has proved by experience to be well suited is shown in Fig. 19. It consists of 4 deal wood boards 8' to 10' long, 9 inches wide and  $1\frac{1}{2}$  inches thick, joined together by vertical teak battens 4 inches by  $1\frac{1}{4}$  inches screwed on to them. For clamping these in position, so that they should not move apart or deviate even a bit from the plumb line, vertical posts of teak wood 3 inches by 3 inches and cross pieces of wood at top and tie rods of  $\frac{1}{2}$  inch iron bar at bottom and

centre are required for this.

It is likely that the cost of such shuttering would be high—rather disproportionately high, for a small single cottage, and also out of the reach of the poor cottage-builder, but if 3 or 4 house-builders combine together or contractors get them made and use them successively on several works, the expenses might be distributed over all of them and the incidence of cost on any single cottage would be reduced.

On an ordinary work two straight boxes, two corner boxes, and four stops for blocking up for doors and windows, would suffice.

The boxes should be packed that they overlap the pinth masonry or the *pise* wall already laid at least 6 inches as shown in Fig. 20. The surface below should be slightly moistened, and loose earth containing sufficient moisture should be spread in 4 inches layers at a time. Each layer should be rammed hard and consolidated till it is approximately reduced to half its original thickness.

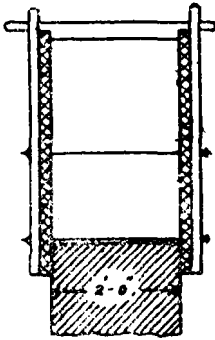
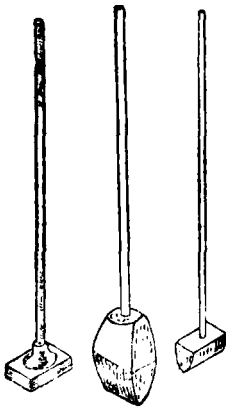

Fig. 20.

Rammers :—The ordinary rammers used for consolidating road metal or concrete are of no use for *pise* work. Three rammers of different shapes are required. The one shown in Fig. 23 is V-shaped. Its peculiar shape causes the pressure to be concentrated on a smaller area and prevents mud sticking to it; again it can be used towards edges and corners. The one shown in Fig. 22 serves the same purpose better as it is heavier. After using these for some time, the one shown in Fig. 21 which has a flat bottom should be used. This distributes the pressure evenly on a large area, and is useful also for surfacing. The rammers should be either of iron or hard wood. If



Figs. 21, 22, 23

wooden, the surface should be quite smooth. A layer should be said to be sufficiently rammed when the rammer thrown from a height of 2 feet does not leave any mark on the surface. At junctions a slope should be left. Edges and angles should be rammed with special care. Hard ramming is the secret of the *pise* walls. It forces out the moisture and brings the particles closer together, which causes their cohesion to increase enormously and prevent the earth from shrinking and cracking.

A special point should be noted while ramming, viz. that the rammers should never work in unison, i.e. the workmen should not strike the rammers at just one and the same time, but one after another. Because, if they do it all together, severe vibrations are set up in the entire wall, in consequence of which, it is likely to be separated from other walls, not under rammers.

At the close of each day's work, it is necessary, especially during summer in this country, to cover the top of the wall with moist gunny bags.

**Speed of work** :—For Indian climate it is advisable to fill and ram the boxes by day and allow them to remain in that position during night so that the earth, in moulds, to shrink sufficiently for the easy removal of the boxes in the morning, which should then be put up again. Out of the total height of the box, six inches go in the overlap. Hence, if they are 3 feet high, only 2½ feet are useful. Therefore, 3 to 4 feet high boxes may be used according to the strength of the labour available.

Lintels over doors and windows may be put at the proper level as usual, with the only proviso that their ends should spread out at least 12 inches on each corner.

Jambes of doors and windows may be formed by arranging the stops at the particular angles.

**Beams** :—The *pise* walls are capable of bearing not only the weight of the roof but also of floors. Actually, buildings, three storeys high, have been constructed; two-storeyed buildings are quite common. These are without any wooden or iron posts embedded in the walls, but beams are laid directly on *pise* walls and upon these the floors are built. The ends of the beams should rest on pieces of boards of hard wood 3 or 4 feet long and 3 inches thick, so that the pressure may be distributed on a larger area. Fig. 24 shows wooden joists laid directly on a wooden plank on the top of the *pise* walls.

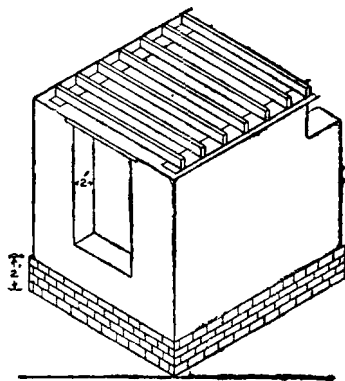

Fig. 24.

For fixing pegs, picture rails, etc., plugs of wood may be built into the *pise* wall during the construction at the proper levels.

**Plastering** :—It is not necessary to plaster the inner surface of walls at all. All that is required is to pare or dress it by means of a shovel or paring instrument (Fig. 15) and make it smooth with a mason's trowel laid flat rubbed against it. If necessary, the trowel may be occasionally dipped into water. However, if it is desired to plaster the wall surface,

it is necessary to make marks or dents on it close together by means of some edged wooden or iron instrument. This is better done when the wall is fresh and wet. After the dents are made, the extra loose earth should be removed with a hard coir brush, water sprinkled over it and a thin coat of plaster of either cement mortar or lime mortar applied to it. It is essential that the wall should be thoroughly dry before the plaster is applied to it, otherwise

the moisture will cause the plaster to peel off. Indenting the surface is quite necessary to give a key to the plaster to stick to the wall.

**Roof** :—Rafters should be nailed to the wall-plates, laid on the top of walls. The roof must be absolutely water-tight and it should project a little more than usual, say 2 to 2½ feet beyond the eaves, to protect the upper portion of the wall from wind-blown rain.

**A practical difficulty** :—It is possible that on account of hard ramming the planks of the shuttering may bulge out a little; to prevent this, strong cross ties to bind together both the faces of the shuttering are required. If the latter are of ropes they will stretch or even break under the stress. If iron rods are used and are bolted on the outside, they will be difficult to remove. Hence, two methods are found to be suitable: one, to provide wires and to cut them at the ends at the time of disengaging the boxes and allow them to remain permanently in the wall after the shuttering is removed. Second, when the surface of earth reaches the level of tie rods, which in this instance should be of wrought iron bars about ¾ inch round, sand, should be put into the box so as to encircle the rod. It will be found afterwards that if some suitable leverage is applied at one of the ends, the rod can be easily pulled out. The sand may be removed as much as possible and the holes plugged with earth thrust into them from both ends.

#### 5(d) Walls of Stabilised Earth

Considerable research has of late been made on soils with a view to stabilising them so as to render them suitable for walls. As a result it has been found that with a suitable material earth can be stabilised and can be used as a cheap material not only for walls of houses, but also for village roads.

Some soils, as they are dug out, may be quite suitable, but most others require to be graded so as to contain proper proportions of sand, silt and clay. Clay, and to a certain extent grit, are the binding materials, and sand serves the purpose of preventing excessive shrinkage. The exact proportions, as well as the necessary moisture content are determined by laboratory experiments.

The stabilisers so far used are: (1) cement in the proportion of 2.5 to 5 per cent depending upon the quality of the soil, (2) linseed oil cake about 3 per cent, and (3) bitumen about 2.5 to 3.5 per cent, in the form of asphalt.

However, the stabiliser by far most commonly used is the first, viz. cement, and the best results are obtained with this, if the soil contains a large proportion of grit or *murumy* matter. Laterite soil, which is disintegrated laterite rock is found to be the best, not requiring admixture of any other soil. This is found in large tracts containing reddish brown particles of gravel and grit, along the West coast of India, Mysore, Hyderabad (Deccan), Midnapur, Bihar, Orissa and Madhya Pradesh.

H-4.

The stabilised soil is put into moulds and compressed, either by hand or better in a machine to form blocks. If cement is used as the stabilising material, the blocks must be cured under moist conditions for 7 to 10 days. The blocks attain a much higher crushing strength than that of burnt bricks.

The walls are built from foundations to the top of the plinth in the conventional manner with stone or brick, and only for the superstructure the blocks are used with lime or cement mortar just like bricks, and pointed on the exposed face.

A large number of small units of this type have been built by the City Improvement Trust Board of Mysore for housing their labourers in the Yashvantpur Industrial Area.

#### Water-proofing of Exposed Surface of Earth Walls

We have seen in a previous chapter how important the question of keeping earth walls dry is, not only from the point of view of their stability but also from that of preventing damp, for the preservation of the health of the inmates. One of the sources of damp is the moisture absorbed from the wet air or that driven by rain striking against the wall surface. The material used for water-proofing must satisfy the following conditions.

- (a) It must be absolutely non-absorbent, i.e. it must be compact, and devoid of pores. Certain tallows are non-absorbent and water-proof, but they do not stand the heat of Indian climates.
- (b) It must stick well to the surface so that even during changes in weather conditions, it must not peel off.
- (c) It must be hard enough to be not easily scratched or damaged by anything striking against it.
- (d) It must be cheap and also pleasing to the sight.

A few suggestions are given below :—

(1) The usual method of giving an annual wash to the wall surface with white earth and cow-dung, mixed together, applied by hand does really protect the wall temporarily from wind-blown rain. This may still be improved upon by adding some cement to it. 12 parts of earth, 4 of cow-dung, and one of cement are the proportions experimented upon by the author and found to give satisfactory results.

(2) Coal-tarring the surface. This should be done only after the walls have thoroughly dried. Otherwise, the coat of tar will come off in the form of scales by the sweat of the wall surface. The tar should be boiled and made thin. To this may be added some powdered dry pitch (coal-tar) while being boiled, and when of the proper consistency, should be evenly applied while

hot, with a brush. This remedy is fairly effective and is good also from the sanitary point of view. But several people do not like the dark surface, besides, it absorbs heat. To remedy this defect, two or three coats of white-wash may be applied on it when the tar has thoroughly dried.

(3) The following is recommended by the U.S. Bureau of Standards in Abstract No. 1806 issued by the Building Research Station, Garston, near Watford, Herts. :—

“Make a solution of 12 oz. of paraffin wax in one gallon of gasolene (petrol). The melting point of the wax should be above the highest summer temperature of the walls and the solution should be applied when the wall is dry and warm.”

(4) The simplest and perhaps the cheapest recipe which the writer has experimented upon and found most successful is to prepare a sort of paint by mixing ordinary ‘white’ or *chopan* earth in boiled linseed oil of the proper consistency, so that it can be easily applied with an ordinary brush. This has the special advantage that all the materials are easily obtainable and the process is very simple. If necessary, some colouring pigment may be used; instead of complex colours obtainable in the market, it is best to use ‘geru’ or red earth, or iron oxide ‘Hurmuz’, *Multan (peeli) mitti*, or yellow ochre, etc., which are cheap and found in abundance in nature.

(5) Another simple recipe is to slake fresh lime first partly with milk (say 5 p. c.) and then with water, and mix it with linseed oil or in fact with any oil. To this should be added 2 p. c. common salt (by weight of the quantity of dry lime). It would be found that a sort of paste is formed which may be thinned properly by adding water and applied with a brush.

(6) The usual remedy of applying rough-cast plaster is also good. For this the surface may be well indented very closely by an edged iron or wooden instrument while the work is still wet, and when it is dry, it should be scrubbed with a stiff coir brush to remove all loose earth, then watered, and rough-cast cement plaster about  $\frac{3}{4}$  inch thick, consisting of three parts of sand and one of cement may be screeded or dashed on the wall surface so as to spread evenly. Cement colour looks quite well; but if desired, some pigment may be mixed with it.

## 6. Wattle and Daub Walls.

In districts close to forest areas, bullies (round rafters) of teak or other good timber are available at a cheap rate, and material for lath, such as bamboos, reeds, or straight and thin branches of certain trees which are strong and tough, is also to be found in abundance. It would be very cheap at such places to construct a framework of bullies (round rafters) and for the walls, a sort of wattle or rough trellis of the reeds or split bamboos may be made and thickly plastered with mud on both the sides. This could be further improved

if the wattle is nailed in double rows on both sides of the bullies, and moist earth moderately rammed between them. If this is done, heat can be effectually shut out. If split bamboos are used, a precaution to lay them in such a way that the glazed side is inside is necessary, otherwise mud plaster will not stick to it. The strength and the life of plaster can be considerably increased if a mixture in the proportions of 12 of earth, 4 of cow-dung and one of cement is made and the plastered surface leaped with it.

This sort of wall construction is subject to the attack of white ants. Especially if bamboos are used, the wall must be renewed every third or fourth year. It is, therefore, suitable for buildings of a temporary nature, such as cow-sheds, barns, farm-houses, etc.

### 7. Flagstone-lined Walls.

Another suggestion for cool walling which is cheap, is useful in districts where thin paving slabs of stone such as Shahabad, Tandur, Kadappa, in the Deccan and South India, or Katni, Rajputana, Chamba, or Rewari, in Central and Northern India, are sold at a very cheap rate. A framed structure of teak bullies with roof either flat or pent, supported on vertical posts may be constructed. The intermediate spaces between the posts may be filled with a wall of sundried bricks on the inside and the above-mentioned slabs on the outside or on the exposed surface. They should be laid erect on edge one above the other, filling the joint with lime, or better still, with cement mortar. If the slabs are  $1\frac{1}{2}$  inches thick and are laid perfectly in plumb, and if, as an additional safety, iron clamps with diamond-shaped pieces of thin sheet, just to support the four corners of slabs on the face and a tail piece embedded in sundried bricks are used as shown in Figs. 25 and 26, there is absolutely

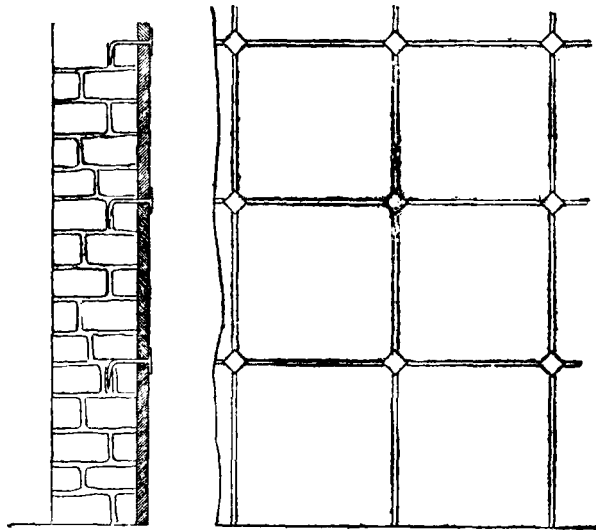

Fig. 25—Cross Section

Fig. 26—Elevation.

no apprehension of their ever being dislocated. They will stand any rain and are bound to remain cool. If slabs are very cheap, they may be lined on both the sides, and moist earth packed in between them as work progresses.

One often sees glazed tiles fixed in this manner to line the wooden walls of lavatories in second class railway compartments where they use brass clamps at corners and nail them to the woodwork behind. The above suggestion is based on the same principle.

If the diamond-shaped heads of iron clamps are fixed in cement mortar and painted from outside, not only will they remain permanently in position unaffected by rust, but they will give in addition a decorative effect to the wall surface.

### 8. No-frango Walls.

This is a method of construction with cement concrete, reinforced with hessian, or jute fabric (used in preparing gunny bags), instead of steel rounds in ordinary R.C.C. construction. It was invented by Major J. H. De Waller of Dublin about 25 years ago. As all the materials viz., jute fabric, cement and sand are all indigenous materials, available in plenty in this country, and as the product is proof against water, fire, and vermin, cheap and strong, it was once hoped that an ideal material for cheap housing was at last discovered. But unfortunately experience has shown that jute rots in the course of a few years in the tropical climate of this country. Hence though it may still be useful for partition walls inside a house, its use in such important details as roof, floors suspended on walls, beams, etc., is not commendable. It can be used for even exposed walls of unimportant structures such as barns, stables etc. The method of constructing partition walls is described below :—

The foundation should be filled and masonry laid up to the plinth as usual. On the top of the plinth, vertical wooden posts, or studs as they are called, say 2 inches by 2 inches in walls which serve merely as partitions may be erected, spaced at 3 to 4 feet apart. It is desirable to give a coat of hot coal-tar on them and to fix their bases in cement concrete blocks, either pre-cast with holes in their centres to receive the bottom ends of the posts. If the house is to have but a ground floor only, a wooden wall plate 3 inches by 4 inches may be fixed on the tops of the posts to which the rafters of the roof may be nailed. The reinforcing fabric of the hessian which should be, if possible, of special make with open mesh of at least  $\frac{1}{4}$  inch should be tacked to the posts at one end and stretched tightly and fixed to all the remaining posts also by means of tacks. The jute strands of the fabric should be, as far as possible, straight, that is, not much twisted. The fabric that comes directly from looms without passing through rollers or undergoing the calendering or sizing process is the best. The test of this is that it should present a hairy, coarse texture. The idea is that in the interest of maximum strength, the fabric should be as thoroughly im-

pregnated as possible with the cement grout which is to be applied to it. Too much twisting and sizing leads to bad impregnation of the strands by cement. The stretched fibre should then be thoroughly soaked with water and, while still wet, a grout prepared with one part of cement to two of fine sand mixed in water should be applied to it by means of a brush, both on the inside and the outside of the fabric surrounding the outer surface of the posts. While this grouting coat is still wet, cement mortar consisting of one part of cement and 3 of coarse sand, should be screeded against the surface with a mason's trowel to form a key to the plaster to be applied to it later on. Then 2-inch wire nails should be driven into the posts at random and left projecting  $\frac{3}{4}$  inch beyond the surface just to hold the layer of plaster which should be commenced as soon as the mortar already screeded is sufficiently hardened. This plaster should be in two layers; the first about  $\frac{1}{2}$  inch thick, with 3 parts of coarse sand and one of cement, and when this has sufficiently set, another of equal thickness, with mortar of the same proportions of cement and sand, but the latter should be slightly finer. The inside of the fabric should also be plastered but it is not necessary to give two renderings; only one of about  $\frac{3}{8}$  to  $\frac{1}{2}$  inch thickness is sufficient and need not also be made smooth.

When this is done, fabric may be similarly fixed on the inside of the posts also to form a hollow space between the two fabrics. The process of soaking with water, grouting, and plastering should be repeated as in the case of the outer fabric, the only difference being that it is not possible to plaster both the surfaces of the inner fabric.

If insulation from heat is to be aimed at, it is necessary to seal the cavity, of whatever thickness, between the coverings of fabric. Generally, a single cavity is sufficient, but in countries subject to extremes of climate it is possible to attain any degree of insulation by providing two or more sealed cavities. It is also possible to leave a cavity of 9 inches to one foot thickness and fill it with earth moderately rammed such as was suggested for a form of walling with a lining of thin paving slabs.

Cavities in walls not only prevent heat but also damp from outside. Walls with a sealed cavity of even  $\frac{1}{4}$  inch have proved successful.

No-frango walls have a special advantage, viz., that they are rat-proof.

Many houses have been built in Ireland after this fashion with not only walls, but even floors, staircases and roofs of No-frango construction, and have been giving perfect satisfaction these 25 years.

---

## Protection Against Rats and White Ants : V

Rats are a distinct danger to health as they are carriers of fleas, which often bear germs of plague. They, especially the bandicoot variety, are particularly to be guarded against in houses with mud walls and *murum* or mud floors, because they burrow under them and dig tunnels which often affect their stability. Their work in this respect is made easy by damp, if present in the walls, because it causes earth to lose cohesion, and therefore, the latter comes out easily at the slightest effort on the part of the rat. Thirdly, they eat out corn and other food-stuffs and even more important than this is the fact that they cause a greater loss by doing damage to it. Hence, special safeguards have to be taken to prevent them from harbouring in the neighbourhood of the house. If we make a careful study of their habits, we find that they make their abodes either underground under walls or floors, or in the roof, and that for their underground habitation they make holes by burrowing at the junction of the walls and the floors. This gives us some clue to work on some definite lines. A few alternative suggestions are made below :—

(1) The floors may be made of lime concrete. A layer 3 inches in thickness of concrete of stone metal, or brickbats-and-gravel in lime mortar rammed hard, will suffice and this can be done at a small cost. While still wet, if a dry mixture of two parts of very fine sand and one of cement is very sparingly sprinkled to form a layer, say,  $\frac{1}{2}$  of an inch thick and the surface polished with a mason's trowel, a very durable and decent floor is formed.

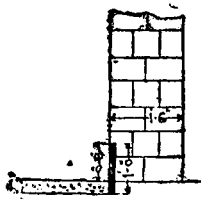

Fig. 27.

In addition to this, the walls on the inner side may be lined at their junction with the floor with flooring slabs or slates. Even the thinnest slabs would do. The slates may be one foot in width and may be so laid in lime mortar that about 3 or 4 inches go below the floor and 8 or 9 inches remain above it, as shown in the marginal sketch (Fig. 27). The concrete flooring and slate or slab skirting effectually preclude the harbouring of the rats under the ground surface. If slabs are costly, lime or cement plaster one inch thick may be laid instead of one foot skirting of slabs.

(2) Second suggestion is to insert galvanised wire gauze netting  $\frac{3}{4}$  inch mesh about  $\frac{3}{4}$  to 1 inch below surface at the junction of the floor and wall on the inner side. This sort of wire netting is usually employed round tennis courts on which creepers of luxuriant foliage usually trail and can be had of 3 feet width very cheaply. It should be bent at right angles and 18 inches should be laid flat horizontally into the wall plaster. If a rat tries to burrow out a hole, he can go as far as this netting against which, however, he is helpless.

(3) The third is an ingenious method and requires to be tried. It is this : Ordinary mud used for plaster should be mixed with finely powdered

glass or hard flint and used as a material for plastering the lower one foot of walls, and similarly, powdered glass should be used in concrete for surfacing one foot near the edge of the flooring. If the powder is fine and if a smooth surface is made by polishing it with a trowel, there is no fear of getting one's fingers cut or scratched if one happens to rub them against it. However, to the rat it presents a distinct danger. Because as soon as it begins to burrow out with its teeth, nasty cuts and scratches to the tongue are sure to be made which would cause it to desist from the attempt.

For preventing rats harbouring in the roof, it is comparatively easy to construct such roofs as would block their passage into the cavity under the roof.

Another source of danger to which mud-houses are liable is that from termites or white ants. All timbers, except teak and perhaps one or two others, are attacked by them.

The remedies consist mostly of the preventive measures which are given below :—

At the time of clearing site and before building operations are commenced, a careful search should be made and any evidence of white ants should be removed by digging out their nests and destroying the queen ants at bottom and grubbing up old tree trunks showing the slightest indication of their activities.

In places where the trouble is apprehended most, teak alone should be used, even if it costs a little more. Or, whenever possible R.C.C. (Reinforced Cement Concrete) work should be substituted, e.g. for door frames, wall plates, posts, etc. It is even cheaper than timber.

Timber should be used only in exposed situations. White ants do not like their activities being watched and interfered with. Hence, they prefer dark, secluded, damp places where their lonely activities are least likely to be interrupted.

Posts, door-frames and such other members of the structure, which usually have to touch the ground, should be provided with stone or concrete heels to avoid direct contact with ground, and sides of door-frames, wall-plates etc., which have to be partly or wholly embedded in masonry should be given a coat of hot coal-tar before being put in position. Coal-tar contains 30 to 40 per cent of creosote which is an excellent ant-destroyer. Hence, if very hot and thin coal-tar is applied, the creosote is absorbed by the pores of the timber, which makes it resist their attack.

Only the absolutely dry and well-seasoned timbers should be used. All sources of damp should be vigilantly watched and precautions taken to remedy them promptly.

Timbers in situations exposed to sun and rain should be treated with some preservative paint or simple boiled linseed oil. Crude oil also is cheap and effective but has to be applied every year.

## ! Doors, Windows and Cupboards : VI

Doors are unavoidable, although they form one of the costly items in an estimate of a building. A teak door of the minimum size, viz. 2½ feet by 6 feet even if of plain design, costs Rs. 180/- at the rate of Rs. 12/- per square foot. Besides, it necessarily requires either an arch or a lintel. If the latter be of R. C. C. which is much cheaper than wood, another amount of Rs. 15/- has to be added. Thus a single door costs Rs. 195/-.

Hence, it is worthwhile to carefully scrutinize the plan of the proposed house and to see if it is possible to reduce the number of doors by considering several alternatives of grouping of different rooms. Of course, convenience should never be subordinated or sacrificed to economy. Still very often too many unnecessary doors are provided. They not only increase the cost but also make the structure weak by leaving so many hollow spaces in the otherwise solid walls. They also interfere with the privacy inside the house.

Another way of effecting economy on this item is to allot different widths to different doors according to the purpose of each. Thus the front door through which heavy pieces of furniture are likely to be carried in and out, need be 3 feet wide, if not more, but doors in the inside partitions need scarcely be more than 2 feet 6 inches wide. For doors of bath-rooms and W. Cs. even 2 feet width will suffice.

The same may be said with regard to height; 6½ feet should be quite ample. Heights of 7 feet or more are fit for public houses, such as schools, libraries, theatres, etc.

Again, fanlights or ventilators on top of doors may be useful, if the doors are in exposed walls, and not in interior ones. Even in exposed walls if concrete *jali* is fixed high up, it would serve the same purpose with economy too.

A third source of economy is to provide one leaf only instead of two, wherever possible. There is a saving not only in wood and labour but also in hinges, tower-bolts, etc. They are particularly suitable for bath-rooms and W. Cs. and in partition walls. When placed at the end of a wall, a single leaf door opens against the surface of the wall, and in this position it takes up the least space and obstructs the least. In a bed-room it contributes to increase the privacy, because when open, it conceals the view behind it.

Yet more room for economy will be found by making a door sufficiently strong to suit its particular purpose. In order to stress this point further to

make it clear, let me ask a question "What is the function of a door?" The obvious reply is that the function is two-fold—first, to protect the household from thieves and unwelcome intruders, and the second, to afford free circulation and privacy. So far as these two objects are concerned, we are perfectly justified in making all the doors in the exposed walls strong and stout, as we have been already doing all along. We should be equally justified in making the doors of the internal safe room, if any, strong and thief-proof. But the question remains—"Where is the necessity of making all the internal doors also of uniform strength when their only purpose is to afford privacy and circulation between different rooms of the same house?" In fact, we indiscriminately make the interior doors also unnecessarily strong as if thieves are coming to break the doors, even of the kitchen and the lavatory with an axe! They need only be sufficiently strong to withstand the rough use to which they are often subjected.

Light leaves would mean light frames also. No such stout frames of heavy scantling as 5 inches by 3 inches or 4 inches by 3 inches, would any more be required. Just 2 inches by 3 inches would be quite sufficient. That alone means a saving of 50 per cent in the cost of the framing material.

The ideal design should, in the writer's opinion, embody the following features :—

**Frame :—**This may be of steel, either a T-iron or angle-iron of very thin section, of pressed steel. It should be fixed by means of steel holdfasts rivetted to it, well anchored into the side walls, or of a thin section R. C. C. either pre-cast or filled *in situ* by means of cement grouting.

**Leaf :—**The frame of the shutter should also be of steel, either of sheet, bent to form a hollow square section or angle-iron. The intermediate panels, which may be 2, 3 or 4 in number, should consist of water-proof canvas with suitable designs printed on it, stretched and fixed to the inner edges of the panels by means of fillets screwed or bolted on to them as shown in the sketch (Figs. 28, 29 and 30). It is thus possible to choose the colour of the canvas, so as to conform

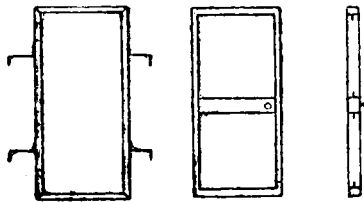

Figs. 28, 29 & 30.  
Frame, shutter and vertical section of a door.

to the general colour scheme of the room. The door might thus form a feature in the interior decoration. It is also an easy matter to clean the water-proof canvas with a moist rag, and as for its wearing qualities, since even for camp lounges or easy-chairs, canvas lasts for years together, its lasting qualities or use in panels cannot be questioned as it is subjected to no stress in the position of a door panel.

Such shutters are likely to rattle and make a noise when opened or closed with a bang, to stop which, the frame may be lined with felt, or fillets of hard rubber, fibre, or lead, etc., may be fixed at 3 or 4 places as is usually done on the window frames of compartments of railway carriages.

A general line on which the design might be made, has been indicated here. It is up to the manufacturers to perfect it and offer it at a minimum cost. It should be possible to offer such a complete door with frame for less than Rs. 40/- to Rs. 50/-. Such doors will have an additional advantage of being absolutely free from the risk of fire or of white ants and dry rot.

So long as such enterprising manufacturers are not forthcoming let us be content with one of the following means temporarily improvised.

A frame of 2 inches by 3 inches scantling of teak wood embedded in the wall as usual and shutters made of a frame of 3 inches by 1 inch teak with intermediate panels filled with either of the following :—

- (1) Cardboard with wall papers of designs pasted on to it.
- (2) Thick canvas stretched and painted in suitable colour.
- (3) Asbestos cement sheet.
- (4) Masonite or similar boards.
- (5) Gunny cloth stretched and coated with cement grout (No-frango) etc.

All these are very cheap, light and durable materials.

Sills of door frames may be necessary for doors in exposed walls in order to keep off vermin; but if they are omitted in the case of all interior doors, not only would economy be effected, but obstructions would be removed and the work of cleaning floors would be facilitated.

### Windows

Shutters and frames of all the inner windows can be made of lighter design as suggested for doors in the previous chapter. If iron bars are provided for windows, and suitably stiffened by a horizontal iron plate, ordinarily there should be no fear of thieves. Hence a cheaper design for shutters of the windows even in the exposed walls can be adopted. The usual scanting adopted for a window frame is 4 inches by 3 inches. Sometimes 4 inches by 6 inches is also to be met with. For windows of the ordinary size suitable for cottages, even 3 inches by 3 inches, should be quite sufficient.

It is very economical to have long and narrow windows in preference to low and wide ones. There are two reasons for this. First, that both the span and the thickness of the lintel is reduced—length, because the window is narrow, and thickness, because the span is small. Second, that if the

window is high, say, almost touching the ceiling, there is very little weight to bear on the part of the lintel and hence the section may be thin. Narrow window would also save a few iron bars.

This arrangement of long and narrow windows is beneficial also from the sanitary point of view because the air, made foul and hot by human respiration, rises to the top in a room and if outlets at this level are not provided, it cools down after some time, becomes heavy and descends, to be breathed in again. Windows, opening almost to the bottom of the ceiling provide such outlets and help in driving it out to be replaced by fresh air from outside.

Again if the design of the elevation is somewhat suitably altered such long and narrow windows would form also an architectural feature from an aesthetic point view.

Another hint in the interest of economy may be given. If a door and

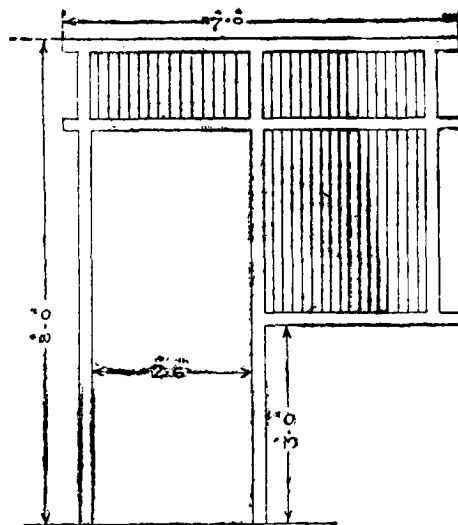

Fig. 31.

a window are combined together as shown in Fig. 31 considerable saving is effected. It is far more than what a casual observer may imagine it to be on the first thought. With the dimensions of the door and window shown in the sketch, there is a saving of 8 feet length of wood; because, not only one vertical side piece of the window, but five pieces projecting at corners, i. e. in all about  $\frac{1}{2}$  of a cubic foot of wood and three feet length or 2 cubic feet of lintel are saved. This means a net saving of about 20 rupees, which is more than 20 per cent on the cost of an average window.

One more suggestion for economy is to utilise the space below the sill of a window for a cupboard. Ordinary cupboards require lintel at top; but this particular cupboard does not; because, there is already a lintel at the top of the window. Thus a cupboard is formed for a small cost only in a space which otherwise would have not only been wasted but filled with solid masonry, which, moreover, is saved if a cupboard is placed there.

Another use of this space in the wall below the window-sill is for providing a seat, especially in such windows as command a good view of the landscape. Even then, either a box for storing linen or a chest of drawers may be provided below the seat.

Very often money is unnecessarily wasted in providing elaborate ornamental projecting cornice below windows on the exposed side. The object of

the cornice is to allow the water collecting on the sill to drop away from the face of the wall. Hence, if a good slope is given and a drip moulding is provided any cheap cornice of simple design either of cement concrete, brick or Shahabad or other slabs, will do equally well.

In most parts of India, weather-boards, or window-hoods as they are often called, are required to prevent the wind-blown rain getting into the window openings. These act also as sun-shades in hot weather. If such weather-boards are provided, shutters to the ventilators above the window proper may be omitted. At the most some wire gauze netting to exclude birds, is quite sufficient.

A hint for economy in the annual maintenance and repairs charges of doors and windows, and in fact, of any exposed wood employed in building construction may not be out of place here. The exposed wood has to be painted for protection against sun and rain which cause it to disintegrate and also they otherwise look shabby. Paints are costly both initially and afterwards for renewal. But if they be selected of a dark or slate or grey colour, the latter can be preserved for a long period by a periodical coat of kerosene or at the most pure boiled linseed oil. They retain at the same time a good and neat appearance. If blue, green or similar other colours are used they soon fade away and if not renewed almost annually, the cottage presents an appearance of neglect.

Another means of reducing the bill on account of doors and windows is to cast their frames with cement concrete in a mould specially prepared. The section need not exceed the usual one of timber, viz. 4 inches  $\times$  3 inches and one rod of steel  $\frac{1}{2}$  inch in diameter should suffice for the reinforcement. This sort of frame costs Rs. 5/- per cubic foot as compared with Rs. 8/- per cubic foot of teak wood frame. Though the saving is not much it possesses the advantage that, it is free from the danger of fire and attack of white ants. A difficulty in respect of fixing hinges for shutters, by means of screws in the above-mentioned concrete frame is likely to be experienced. But if hollow spaces are left in the frame while moulding at the places of hinges, by inserting wooden plugs and if these hollows are subsequently filled with concrete made of 4 to 6 parts of screened coal ashes and one of cement, hinges can be fixed very firmly in it by means of ordinary screws as if in a wooden frame. Detailed instructions regarding the preparation of such frames are given in Appendix No. 3.

### Cupboards

Cupboards ought to be regarded as a fairly good investment, especially in small cottages. Because, not only are they comparatively much cheaper than movable wardrobes, but they cause, in addition, a saving in space and are free from the dust and dirt which usually accumulate below and behind the movable almyrrah. Therefore, no corner or recess under the roof should

be wasted, but turned into cupboards with shutters of whatsoever cheap material, one may like to choose.

Even in earth walls excellent cupboards, safe enough for storing even valuables, can be built, if they are lined on the inside with plain G.I. sheeting or flagstone slabs, even of the thinnest section available, whichever is cheaper.

It is worth mentioning here that very often shelves of Shahabad or similar paving stones prove to be cheaper than wooden boards, which are in most cases, used in cupboards. For shelves, teak boards, one inch thick even at so cheap rate as Rs. 12/- per cubic foot, including planing, fixing, oiling, etc., cost about 4 annas per sq. foot, i.e. they are four times as cheap.

The slabs have the additional advantage that they form one piece without joint whereas teak boards, wide enough to cover the full depths of the cupboards, are still costlier. The stone slabs are again, absolutely free from the danger of destructive white ants and fire.

With stone slabs, however, width of the cupboard is restricted to 2½ feet because 3½ or 4 feet long slabs, though not quite unusual, are not easily obtainable. The standard length is 3 feet out of which three inches on either side go for the ledge in the wall.

Remarks made about the light and cheap designs of shutters for doors in a previous chapter apply with full force to cupboards also.

---

## Partition Walls

## VII

The main function of a partition wall is to divide one large room into two or more smaller ones, which is required for the sake of privacy. Privacy is of two kinds : one, which is required in respect of sight and the other in respect of sound. It is a simple thing to provide for the first. Even a cloth screen is sometimes sufficient. But it is very difficult to make a perfectly sound-proof partition. A feeling of privacy in respect of sound, particularly in some rooms is one of the factors which go to make a house comfortable. A thin partition of plain galvanised iron sheet or a framework of split bamboos, battens or wattle plastered over, to serve as partitions scarcely afford any more privacy than the paper walls of a Japanese house.

In rural districts where space is not much restricted, the cheapest partition which is also sound-proof, is one built with sun-dried bricks. A thickness of 9 in. or one foot is sufficient. Earth is a far better insulator of sound than stone or brick. Another advantage of such partition walls is that it is possible to provide plenty of cupboard space in them if they are thicker. This advantage more than counterbalances the apparent waste of space.

In order to be really sound-proof, a partition wall must be carried up to the ceiling, whether flat or sloping. Above the height of the horizontal ceiling level it may be made thinner for economy.

In places where space is very much restricted, thin partitions of No-frango, described in the previous chapter, can be built at a cheap rate. Air is comparatively a better insulator of sound than stone and brick and as the cavity between the two sides of the No-frango partition is occupied by air, the partition, even though thin, is rendered more sound-proof. If it is desired to make it still more sound-proof, the cavity may be filled with felt or loose coir waste or wood shavings or two thin air cavities may be formed.

Glass is a good insulating material, even better than air ; hence a partition of frosted glass provides privacy of either kind. It is, however more costly. Besides, it is liable to be broken every now and then. Glass, with wire gauze netting impregnated in it (wire glass) satisfies this condition also.

### Lintels

Economy in lintels can be effected as already stated on page 60 by combining a door and a window together, so that the combined length is much less than that of the two separate pieces otherwise required.

Another way is to design high and narrow windows, which cause a reduction in the length and also in the thickness of the lintel.

As far as possible wooden lintels should not be used. For not only are they costly but, if once affected by dry rot or eaten out by white ants, it is both

troublesome and expensive to replace them in that position. For stables, barns and other structures of minor importance, however, economy can be effected by using roughly squared round logs of hard wood instead of cut scantlings, with quarter cut pieces of bigger logs at ends. To prevent loose earth falling down through the joints, plain G.I. sheets should be bent to a form of a channel and nailed from below to the pieces of wood which should be generously treated with coal-tar to prevent them from being attacked by dry rot or white ants.

The next cheap form of lintels is the flat brick arch. It is very simple in construction and suitable for ordinary domestic buildings. It does not require any support or centering during construction beyond a wooden plank at bottom. A radius equal to the width of the opening should be assumed and all joints made to converge to a common centre below. Only sound, well-burnt bricks should be selected and they should be kept immersed in water for 2 hours. Mortar of good hydraulic lime should be used, and if it is not of good quality, a little cement, say, 1 in 50 or 2 per cent of mortar, should be mixed. For a width up to 3 feet, one brick or 9 inches thick arch is sufficient; for spans exceeding 3 feet, 13½ inch thickness should be adopted. The arch should be kept covered with a moist gunny-cloth for at least two weeks.

The next cheapest and simple in construction is a lintel of reinforced brickwork which also does not require a support beyond a bottom plank as above. (Detailed instructions for this will be found in the author's *Build Your Own Home*).

Reinforced cement concrete lintels have now become very common. Instructions for preparing them also will be found in the above-mentioned book. In the interest of economy, it is worth mentioning here that if the walls are solidly founded on *murum* or rock, for spans up to 3 feet there is no need of the reinforcing steel bars, if the lintels are 6 inches thick and if bars are used, thickness of 3 to 4 inches is quite sufficient for lintels over spans up to 4 feet.

Brick arches are comparatively much costlier and do not fit in with walls with mud mortar.

Where stone slabs are available at a cheap rate, the thickness of the stone lintel may be adopted according to the rough rule: to allow one inch for every foot of span, plus one inch. Thus for a 4 feet span, thickness of 5 inches is sufficient.

A mistake is commonly made of building an arch over door or window openings close to the end walls. The result is that the end walls are thrust out of the plumb-line by the load on the arches, tending to stretch outwards and a crack is likely to be formed. The best plan is to provide flat lintels over such openings, and if arches are at all required for the sake of uniformity, a tie at springing, of say 2 inches by ¼ inch flat iron, well-anchored and countersunk in the wall, should be used.

---

## Staircase : VIII

No part of the house requires such a thought and careful attention in designing as does the staircase. Its position governs and modifies the arrangement of the rest of the house. But, unfortunately, this matter of utmost importance is never pre-thought in India and, in most cases, is postponed to be decided at the last moment. It is then squeezed in somewhere into a verandah in a narrow space and with winding steps with such a steep ascent that to climb it is an acrobatic feat. In most cases it is barely 24 to 27 inches in width. It ought surely to be kept in mind that people who build the house for their own residence cannot escape old age, sickness and infirmity some time in their life; that besides, accidents are likely to occur on such staircases and that it is only then that the folly of having constructed a steep and narrow staircase would be realised.

The ideal position for a staircase should be such as will allow it to be approached from every important room independently through a lobby, however, small.

The details of the service requirements of a properly designed staircase have been dealt with at great length in the author's *Build Your Own Home* and it is not necessary to repeat them here.

It is a common practice to build the staircase of wood because it can be made to look as elegant as required and there are also other conveniences in it. But it costs a good deal, particularly for labour and entails the potential danger of catching fire.

A very simple, cheap and fire-proof staircase suitable for cottages is described below :—

Take two pieces of rolled steel joists 4 inches by  $1\frac{3}{4}$  inches weighing 5 lbs. per foot of length, of the required length of the slanting staircase. This length should be previously calculated according to the instructions given in the author's book referred to above. Place them in position at the proper distance apart, equal to the desired width of the staircase.

Their ends at bottom should be securely fixed in cement concrete and the tops also either bent a little and buried in cement concrete, or fastened to the floor in any other way. Take a piece of T-iron, 3 inches by 3 inches by  $\frac{1}{4}$  inch thick, weighing 7.18 lbs. per foot of the same length, and place it midway between the joists, with the T-flange pointed upwards. Thus if the staircase is to be 3 feet wide, there will be two joists at the ends and the "T" between them, leaving between flanges of the "T" and either joist, a space of 18 inches

width. Cover this space by laying Shahabad or other paving slabs  $1\frac{1}{2}$  inch thick with one side resting on the flange of the T-iron and the other on the inner

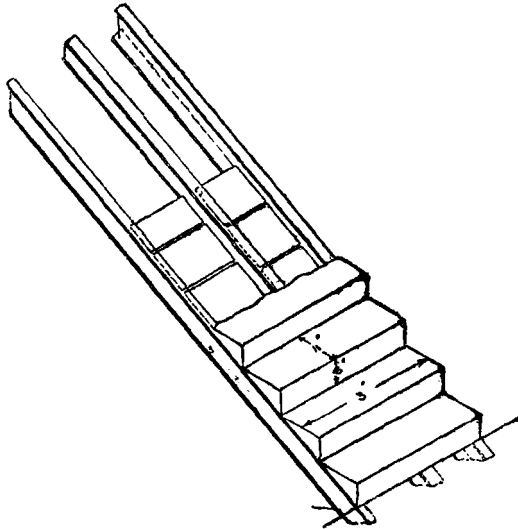

Fig. 32.

flange of the joist from bottom to top as shown in Fig. 32. The joints should be filled with cement mortar and when this is done, start laying brick-work in lime to form regular steps from the bottom. On the top of each step may be laid a wooden board or stone slab with its front edge left projecting half an inch. If stone slabs are not available at a cheap rate to cover the space between the joists and T-iron, expanded metal sheet of the necessary width may be fixed by means of bolts, to the joists and plastered on both

sides with cement mortar to form a slab about 1 inch thick. This makes a cheap, light, sound-proof and fire-proof staircase.

The following is a very simple method of constructing a reinforced cement concrete staircase, which does not require much skill, and hence can be built by any cottage-builder without expert advice. The joists and T-iron used in the above staircase can also be dispensed with in this case.

Take 5 pieces  $\frac{1}{2}$  inch round iron bars of the necessary length of the slanting staircase plus about 3 feet and bend their ends as shown in Fig. 33. If bars of the necessary length are not available in the market, join ends of two bars in such a way that they overlap at least 2 feet and tie the overlapping portion together by means of a wire. Place the rods side by side in the slanting position of the staircase at equal distance apart and tie cross pieces of  $\frac{3}{8}$  inch round bar, and of length equal to the width of the staircase by means of a thin wire at the points where they cross the long bars. When this is done, erect some sort of boxing below the bottom and sides of the iron frame placed as above in position, so that a space of one-half inch remains at bottom and both sides between the steel bars and the boarding of the box. Fill cement concrete prepared in the usual proportions of one of cement, 2 of sand, and 4 of broken metal, the latter below one inch in size, to make a slab of 5 inches thickness. On this lay brickwork in lime to form regular steps.

If it is desired to form the entire staircase of one homogeneous mass of concrete, the sides of the box should have regular steps cut into it. With

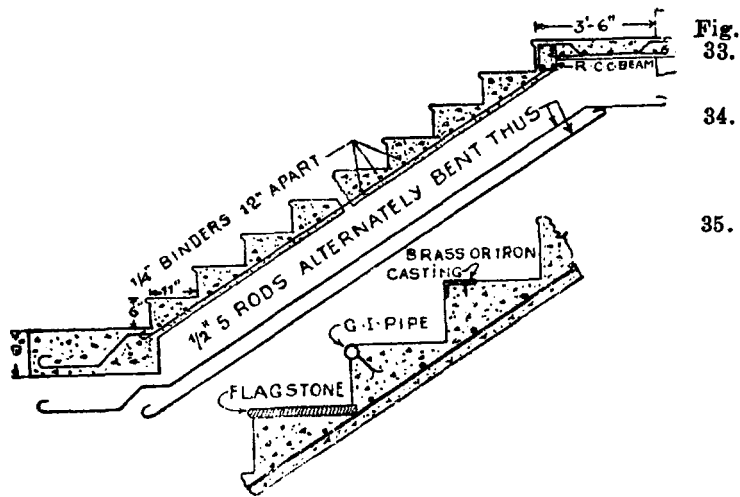

these and pieces of deal boarding nailed to them to form boxing for each step, it is quite easy to cast the entire staircase with steps also of concrete. There is no necessity of any reinforcing bars in each individual step.

In order to protect the edges of the concrete steps against being knocked off, insert either pieces of  $\frac{1}{2}$  inch pipe or brass or steel castings and bind them to the rods by wire before pouring concrete, or lay round-edged flagstones or wooden boards on top of concrete. See Fig. 35 in which all these three different methods are shown in the three steps.

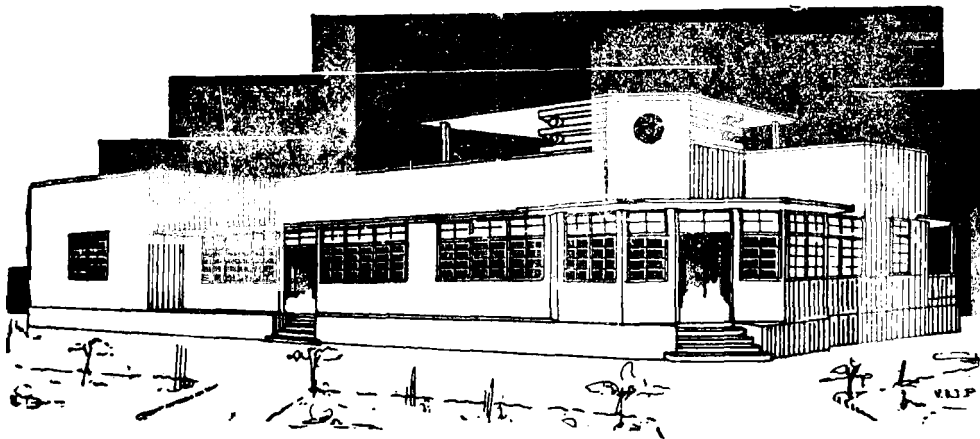

## Flooring

## : IX

The usual form of wooden flooring so common in towns and villages, is not only uneconomical, but it is liable to be easily gutted if the building accidentally catches fire. Besides it involves great skilled labour.

In the author's book *Build Your Own Home* nine different types of flooring have been dealt with. It is proposed to describe here briefly a few cheap ones among them which are also fire-proof.

As a preliminary to starting the work of flooring it is necessary to take a precaution. If the walls which are to support the flooring are built with frames embedded in them (see p. 23) i.e., if there are vertical posts and wall-plates on their top to support the flooring, it is all right ; if on the other hand, the walls are solid and of brick or stone in mud, it is desirable to cover their top with Shahabad or other paving stones, not less than 1" thick, in order to distribute the pressure of the floor evenly on the walls. If such paving stones are costly, lay cement concrete 2 inches thick instead.

Then place on the top of the walls thus prepared, rolled steel joists

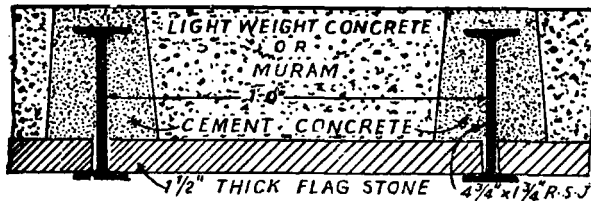

Fig. 36.

4 inches by 1½ inches weighing 5 lbs. per foot of length, if the span does not exceed 12 feet or 4½ inches by 1½ inches weighing 6½ lbs., if it exceeds 12 feet, but is less than 14 feet, they should be spaced 12 inches apart centre to centre (See Fig. 36).

Give a coat or two of bitumen or hot coal-tar to the joists before laying them in position. Then, if paving slabs 1½ inch thick are available at a rate of Rs. 30 to 35 per 100 sq. feet, insert pieces of them one foot wide from one end. If a ledge of ½ inch is obtained for the slabs on the flanges of the joists, it is sufficient. Fill the joists with cement mortar and fill the spaces above the slabs up to the top of the joists with anything light, say, broken pieces of burnt brick, coal clinker, *murum*, etc., and ram it with a moderate force. On top of this construct any sort of flooring of ¾ to one inch paving slabs laid in lime mortar and cement pointed or even simple *murum* flooring will do.

If the rate of the paving slabs exceeds 30 to 35 rupees per 100 square feet, it would be economical to follow the instructions given below :—

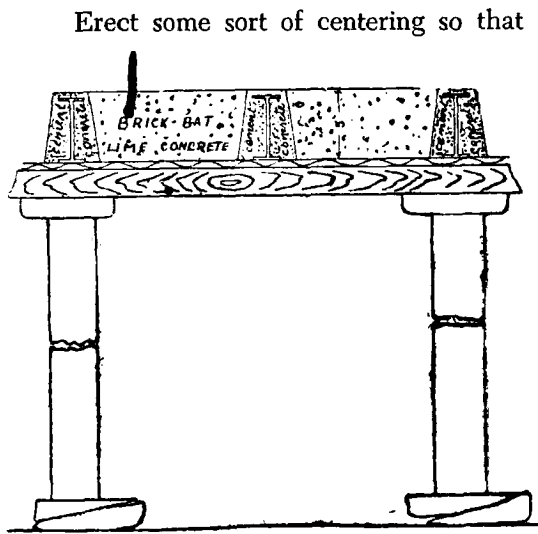

Fig. 37.

shape, 2 inches wide at top and  $4\frac{1}{2}$  inches at bottom as shown in Fig. 37. When this sets, in about six hours, prepare lime concrete with broken brickbats or screened boiler slag 3 parts, sand one part, and put it evenly up to the top of the joists and ram well.

After about a week remove the centering of C. I. sheets from the bottom and place it below the next portion to be prepared. The object of putting cement concrete against sides of joists is two-fold. Firstly, that the alkalis in lime concrete speedily attack steel and cause it to rust rapidly, the cement concrete not only prevents their coming in contact with lime, but increases their strength in addition; and secondly, that the particular shape given to the cement concrete gives the intermediate mass of lime concrete a wedge with the broad part at top and prevents it from sliding down. The whole thing behaves like a flat arch between two joists.

This method is not only very cheap and simple but as it allows small portions to be done at a time, it is possible for even a small cottage-builder to build a fire-proof flooring with only 3 or 4 old C. I. sheets for the centering.

The floor should be kept moist for three weeks by covering it with grass frequently wetted with water. On top of it construct Indian patent stone or lay Shahabad paving stones as may be desired.

Another cheap form of flooring described below is suitable for timber districts, where, hard wood is available at a cheap rate.

For this, take scantlings of well-seasoned timber 4 inches thick and saw them so as to cut wedge-shaped long pieces  $1\frac{1}{2}$  inches at top and 3 to 4 inches

Erect some sort of centering so that its upper surface is about  $\frac{1}{2}$  inch below the bottom of the joists. A centering of corrugated iron sheets (even old sheets will do) is very cheap and convenient. The corrugations give it a stiffness, hence, the wooden supports placed below the sheets, need not be so close together. However, it is necessary to cover the corrugations with mud to make a flat surface and when it is dry, leep it with cow-dung. Then prepare cement concrete with 5 parts of gravel,  $2\frac{1}{2}$  of sand and one of cement and dash it against the sides of the joists to give them a wedge

at bottom as shown in Fig. 38. Treat them generously with two coats of hot coal-tar and place them in position with centres 12 inches apart. At the bot-

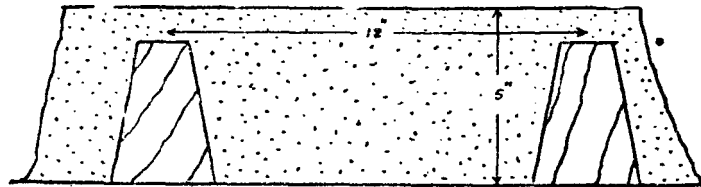

Fig. 38.

tom of the intermediate space, place some sort of boarding or C. I. sheet centering with corrugations filled with mud as described above. Then pour into the space above it, a slightly rich mixture of lime concrete, formed of  $2\frac{1}{2}$  parts of broken bricks, one of sand, and one of lime mortar and ram it well. The centering can be removed after about 10 days.

The wedge-shaped pieces of wood should not be planed but left as rough as possible which increases their adhesion and helps to make the floor stronger.

#### Jack Arch Floor.

Next to these comes the Jack Arch flooring, in simplicity and cheapness. For this, rolled steel joists are to be placed on the walls at suitable

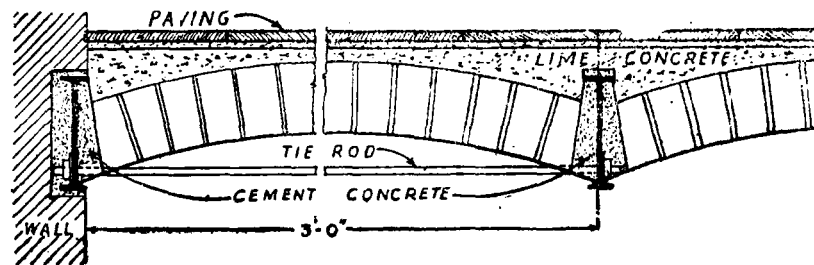

Fig. 39.

distance, say from  $2\frac{1}{2}$  feet to 4 feet and brick arches in lime  $4\frac{1}{2}$  inches thick, are to be built between, as shown in Fig. 39. These arches can be built without any centering\* and, in fact, unless this is possible, the Jack Arch flooring loses its advantage of cheapness.

\* The process of doing this has been described in detail in the author's *Build Your Own Home*.

For the guidance of the layman sizes of steel girders and wooden joists for different spans for the above two methods are given in the sub-joined table.

Table of Steel Girders and Wooden (Teak) Joists

Span in ft.	Bay or space between two girders	Size of steel girder in. × in.	Weight of girder in lbs. per foot.	Size of wooden joists of span length in. × in.
8 }	6	5 × 3	11	2½ × 4
	7	6 × 3	12	3 × 4
	8	6 × 3	12	2½ × 5
10 }	6	6 × 3	12	2½ × 4
	7	7 × 4	16	3 × 4
	8	7 × 4	16	2½ × 5
12 }	6	7 × 4	16	2½ × 4
	7	7 × 4	16	3 × 4
	8	7 × 4	16	2½ × 5

#### Flooring (Ground)

If a house is not likely to be infested by rats, *murum* or earth floors, if properly done, are quite good. They are cheap, easily made, wear sufficiently long, and are easily maintained and repaired. They maintain an equable temperature, i.e., they do not get cold in winter, nor hot in summer, and hence, for Indian People who in most cases walk bare-footed inside the house, they are very suitable. Some people condemn them as insanitary on the ground that they absorb water and that in order to maintain them properly, they have to be frequently coated with cow-dung, which rots, smells, and breeds millions of microbes.

To a certain extent this is true but when all other factors are considered and it comes to choosing between two evils, the writer would be inclined to choose the lesser evil of *murum* or mud floors than that of any stone paving, imperfectly done.

In the houses of the poor, stones for paving, if used at all, are laid generally on top of *murum* or mud instead of on concrete. The quality of slabs and workmanship are far from satisfactory. Again, unlike in the houses of the well-to-do, the floors are subject to rough use. As a consequence, the *murum* or mud sub-layer soon sinks, the joints in the slabs open out and an uneven surface is formed. For proper sanitation, the floor must be washed with copious water mixed with some disinfectant at least twice a week. But in the houses of the poor, this is never done except once or twice during the year on ceremonial occasions or on certain holidays when the whole house is cleaned as enjoined by religion ; that too is done without any disinfectant and

in most cases with a scanty supply of water. One can easily imagine what the process of washing and cleaning would be like, when the surface is rough and uneven with several open joints through which water must be soaking into the absorbent layer of *murum* or earth below! In fact the washing, instead of removing any dirt, multiplies it.

Besides, in certain orthodox sections of the Hindu community even if a particle of food drops down, the ground is defiled, to sanctify which comes a wash of cow-dung! In the kitchen where food is cooked and in the dining room where it is served, local application of cow-dung is made several times a day, no matter what sort of a floor it is. It can be easily imagined to what extent, dirt must be sticking to the rough-grained paving slabs, and with wide open joints, inviting swarms of house flies—the dreadful enemy of human health!

From this point of view *murum* or mud floors are preferable. They are easily made smooth and as such take the least quantity of cow-dung and dry up again very speedily.

Constructing *murum* floors is a matter of common knowledge and experience. Still the salient points which ensure success are described below :—

#### Murum or Mud Floor

All black earth, at least that in the portion one foot below the ground should be removed and the surface should be filled with boulders of stone or brick clinker, packed together in a layer of six inches. Above this should be spread 6 inches of loose *murum* with coarser pieces at bottom and finer at top. On top of this, a layer of powdery or flaky *murum* 1 inch thick should be spread. Then water should be freely sprinkled on the surface which should be rammed well at the same time. After this, copious water should be evenly spread until it stagnates and appears about  $\frac{1}{4}$  inch at top. The surface should be roughly levelled and trampled under feet of workmen until the cream of *murum* rises to the top. It should then be left to itself for 12 hours and then rammed by means of a wooden rasp for two days, both in the morning and evening. After this a wash of cow-dung about  $\frac{1}{16}$  inch thick should be given and the floor rammed again, once in the morning for two days. If it be summer time, it will be sufficiently dry by now and will be ready to receive the final thin wash with 4 parts of cow-dung, and 1 of cement mixed in water and applied evenly, and wiped clean from the surface by hand. If necessary, some lamp black may be added to it for the sake of appearance. The floor made in this way is very smooth, hard, and fairly impervious to water.

If the *murum* be earthy and very soft, or earth has to be used instead, sand may be very thinly sprinkled on the surface on the third day and rammed well with a rasp. Instead of cement and cow-dung, a coat of hot coal-tar may be applied and polished with a mason's trowel. This makes it more impervi-

ous, but some people do not stand the smell, which is unavoidable for a few days in the beginning. Before applying this coat, the floor must be thoroughly dry, otherwise the moisture of the surface might cause it to cake and peel off. *Murum* is available in Southern and part of Central India. Laterite, which is available in many parts of India, also makes even better floors. At other places earth floors are made. The difference in constructing *murum* and earth floor is that whereas water is freely used in *murum* floors, it is very sparingly done in earth floors. If earth, or laterite as it comes from the pit, is moist, there is no need of watering it at all. It should be spread in 6 inches layers and rammed until very little impression is made by the heel of the shoe; then a wash of cow-dung and cement should be given to it as above. While renewing earth floor, the upper layer of at least 3 inches of the old earth must be removed and replaced by new. For *murum* floor, this is not necessary, the old *murum* lasts for 10 to 12 years.

#### Concrete Floor

In places where trouble from rats burrowing under walls is apprehended, floors of concrete may be done at a cheap cost. The surface below the concrete must be absolutely unsinkable, otherwise cracks might result. Where stone is available at a cheap rate, the floor may be packed with boulders about 6 inches thick and upon them should be spread a layer of 3 inches of *murum* or gravel which should be freely watered and rammed. Upon this may be laid 3 inches of lime concrete prepared with 3 parts of metal to one of unscreened sand, free from earth and one of lime mortar and rammed very hard. Upon this should be sprinkled very very lightly, dry mixture of one of cement and 2 of fine sand through a sieve of fine mesh and immediately polished with a mason's trowel so that the cream of lime on the top of concrete dries up and forms with the cement a hard skin layer. This must be done just at the proper hour. This sort of floor, if done well, wears very well and is absolutely water-proof and rat-proof.

#### Indian Patent Stone

This is a further improvement on the concrete floor. In order to ensure absolute freedom from cracks, the sub-layer must be made quite unsinkable with great care. Upon this is to be laid 3 to 4 inches of lime concrete as above and rammed for two days. Before this sets, lay on its top a one inch layer of a mixture of 3 parts of sand and gravel of all sizes below  $\frac{1}{2}$  inch and 1 part of cement, in water evenly laid with a float and rammed at the same time by the mason's trowel, and as soon as it partially sets, that is, in about six hours, another half inch layer of slightly finer sand 2 parts, and cement one part, mixed first twice in a dry state and then twice again in water, should be applied and levelled with a wooden float. Colouring pigment, if necessary, should be added to this mixture and the surface polished with a trowel. A very smooth polish is harmful in two ways. Firstly, the surface is liable to

crack as a thin film of cream of cement rises to the top, and secondly, it becomes slippery.

To prevent the latter, lines crossing each other are drawn about  $\frac{1}{8}$  inch deep. If the surface is long and extensive, expansion joints are necessary. The floor is divided into rectangles by erecting either battens, 2 inches by  $\frac{1}{4}$  inch, on edge or cardboard, and the cement concrete is laid on both sides of it. When the latter sets and dries up, the battens or boards are removed and the space filled either with hot asphalt or coal-tar mixed with sand upto  $\frac{1}{2}$  inch below the top, the space above which is filled up with sand and the joint wiped off. In course of time the asphalt rises up and consolidates the loose sand.\*

Another very cheap, durable, and water-proof flooring can be constructed in the following manner :—

Spread a layer of road metal about 3 inches deep. It does not matter, if the metal is slightly soft, but should not be *murumy* or earthy and liable to be crushed to powder under the strokes of a rammer. Consolidate and level it well in a dry state as is done under a roller for preparing roads so that all the pieces at top are interlocked together, and that there are no loose pieces at the surface. When this is done, pour on it hot coal-tar just enough to form a film of, say,  $\frac{1}{16}$  of an inch. Sprinkle on this, a layer of fine sand free from earth. It should be just thick enough to cover the tarred surface, i.e. about  $\frac{1}{4}$  to  $\frac{1}{8}$  inch thick. This should be rolled with a small stone or iron hand-roller, or if the latter be not available, beat it with a rammer, first lightly, and afterwards vigorously with a wooden rasp. The rasp should be so applied that the surface under it becomes smooth and even.

For the first month, the surface smells of coal-tar which is disagreeable to some people. This sort of floor wears very long and is perfectly satisfactory in every respect.

---

\* Instructions in detail about this sort of flooring have been given in the author's *Build Your Own Home*, especially regarding guarding against failures.

## Plastering

: X

It is usual in India to plaster brickwork in general with lime mortar on the outside. This is done for two reasons :—

(1) The quality of bricks manufactured in India, except perhaps in a few places in N. India is bad. Hence, unless the outside surface is plastered, they present a bad appearance.

(2) At many places the monsoon is severe ; hence, unless the walls are plastered on the outside, moisture is sure to be driven into them by wind-blown rain and cause damp.

But plaster is very expensive both in initial cost and the subsequent maintenance and repairs. Hence, it would be advisable in the interest of economy to avoid it on the exposed surface wherever possible.

To obviate the difficulty due to the first reason viz. to improve the appearance of bad bricks, plaster should not be necessary. Because if a slightly greater attention is given to select good bricks for the face work and pointing is done a little more neatly, a far better decorative effect can be obtained than with plastering. If, however, plastering is required for the second reason, viz., to make the exposed surface impervious to water, it cannot be avoided. Still, economy can be effected in another way, viz., by using cheap bricks ; even ground-moulded country bricks will do, provided they are strong and durable. There is a great difference in the rates of table-moulded bricks of standard size and ground-moulded country bricks. If the surface is to be covered under plaster, then why not use the cheap stuff if it is sufficiently strong?

If it is found necessary to plaster the outside surface of walls, no pigments should be used. The cement mixed in the mortar gives a lasting grey colour which looks quite well.

If walls are built of brick or stone in lime mortar, economy might be effected by omitting the plaster in certain rooms of the house where it is really redundant, e.g. in store-room, fuel-room, loft, etc. It is also very difficult and expensive to maintain it in such rooms because there is every chance of its being damaged every now and then by something striking against it.

When a wall is one brick, i.e. 9 in. wide, it is possible to so build it with care that one of its faces is quite even. If the latter is then rubbed by a hard brick and white-washed, no plastering is necessary on it. If a smoother surface is required, cream of lime may be daubed here and there against it and spread over the surface by rubbing it quickly with a piece of soft brick dipped

into water in which some jaggery is dissolved so as to form a plaster  $\frac{3}{8}$  inch thick or even less. This is very cheap and durable.

Mud plaster is cheap in initial cost and cheaper still in maintenance. It furthermore possesses the advantage that as the building grows old and the wall gets covered with many coats of colour and white-wash, it is a simple matter to scrape off the coats and make the surface smooth again by giving a hand-wash of mud and cow-dung mixed together. On the other hand lime plaster, if scraped, is damaged and cannot be made smooth again even at great pains and expense.

The proper way of plastering the inner surface of walls with mud is as follows :—

Select proper earth ; earth containing too much clay will cake and form cracks ; while that containing too much sand or loamy matter will not stick properly. If earth found in natural state is not suitable, blending the two together in correct proportions will make it so.

It should then be screened through a  $\frac{3}{8}$  inch mesh sieve so as to exclude bigger stones and lumps of earth, and be left to soak into water for at least 24 hours. Some people allow it to soak for a month, but unless the earth has salts in it, the advantage is dubious. On the contrary, unless it is turned over and mixed with water every day and kept in a pulpy condition, it is likely to form lumps which are difficult to break.

While mixing, cut straw should be freely added to it. Some people put some cow-dung or crushed droppings of horses with advantage.

The surface to be plastered should be prepared by raking out joints to give a hold or key to the plaster, and the mixture of the proper consistency should be evenly spread on the surface and worked with a wooden float.\* After 24 hours, while it is slightly wet, it should be tamped well with a wooden or metal edge; the dents should be as close together as possible.

The secret of success lies in this tamping. Even if a portion cakes and sounds hollow, the tamping will cause it to stick to the wall permanently again. This must be done in right time because once the inner skin of the plaster dries up, no amount of tamping is of any avail.

After tamping, a thin wash of cow-dung is given and tamping done again at places where small cracks are seen to have developed. Then the final slightly thicker wash of cow-dung and good *chopan* or white earth, or better still, of sodiumised clay (see page 16) is applied by hand just to cover all the indentations made during the tamping process. After this is fairly dry the colour or the whitewash may be applied.

---

\* Float is an instrument consisting of a flat and smooth piece of wood used for planing and levelling plaster.

The above is for plastering inner surfaces of walls. For outer or exposed surface, the same process is to be repeated till after the tamping. The final coats to be given after this must be such as would help the plaster to resist atmospheric influences. Hence, instead of a wash with mere cow-dung and earth, one with a mixture of 12 parts of sodiumised clay to 1 of cement, and 4 of cow-dung should be given to close the indentations. If the earth is specially made impervious by the process described on page 16 viz. by mixing salts with it and precipitating it in water, excellent results would be obtained. In that case the cow-dung may be altogether omitted. This makes the skin of the surface hard and non-absorbent, which, in consequence, wears well even in rain. The above wash is very useful for walls of earth.

For making the exposed surface water-proof to resist piercing rain and wind, recipes suggested on page 50 for water-proofing exposed surfaces of earth walls may be noted.

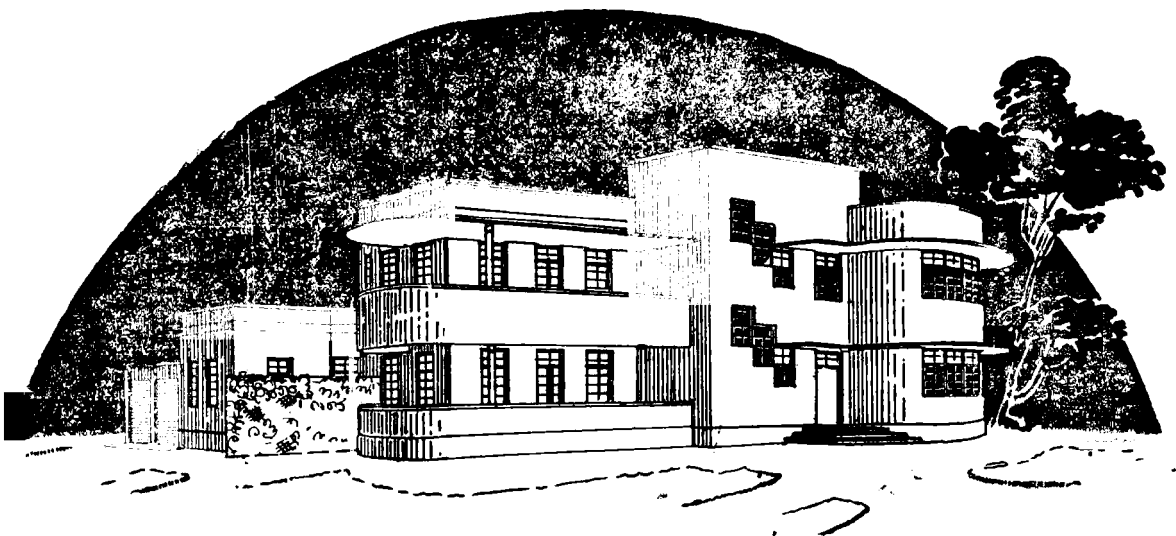

Roofs are of two types; one flat and the other pent. The latter is also called pitched or sloping. On account of the extreme variations in temperature to which all parts of India, except perhaps the coastal region and hill stations are subjected, flat roofs, unless very carefully and scientifically constructed, cannot be entirely relied upon in India. In coastal regions and hill stations also, though the temperature is equable, the proportion of the average rainfall is much greater than that on the plains and therefore there is no less apprehension from leaky roofs than elsewhere. Besides, flat roofs necessarily require a parapet wall which, if not constantly watched and kept neat and tidy, presents a squalid appearance.

If, on the other hand, a flat roof is rendered really water-tight, it provides an extra accommodation for sitting on cool evenings or sleeping during nights in the hot season at a high level. But this advantage does not really count in rural districts where open space surrounding the house is unrestricted.

If a pent or pitched roof, on the other hand leaks, it is easy to set it right. Besides, it always looks elegant and presents a home-like appearance.

In cities and crowded towns, with considerable rainfall it is the best policy to choose a mean i.e. to cover the greater part of a building with a pent roof and construct a terraced roof on the remaining part so that the advantage of a flat roof would be derived, and at the same time, the fear of leaks would be reduced.

It is often argued by the advocates of flat roofs that the latter keep the rooms under them cool, but this is doubtful; because for affording a real protection from the heat of the sun, the thickness must be something like 9 inches which no one ever adopts. The usual thickness given is from 4 inches in the case of R. C. C. roofs to 7 inches in the concrete terraces or mud roofs. The degree of coolness afforded by this thickness can be easily obtained from pent roofs, if a wooden ceiling is constructed and some air space is left between it and the tiles above. With modern insulating materials, any roof can be made cool in summer and warm in winter at a reasonable cost, to any extent.

On the contrary, a building with a flat roof on is fully exposed to sun unlike that with a pitched roof, the projecting eaves of which afford a considerable real protection both from heat and rain, besides keeping the building dry as the water from eaves flows away from it.

Let us take the pent roof first. Thatch is the cheapest material and, if carefully laid in sufficient thickness, the roof gives an absolute protection from

the sun and rain. But there are two disadvantages which very much detract from its usefulness. The first is that it possesses the potential danger of catching fire, and the second, that it absorbs rain-water which causes the straw to decay and give out foul gases.

Then come tiles, either half-round or flat, which have been used from very old times. They however, absorb heat and are liable to be broken by monkeys and have therefore, to be turned and partly replaced by new ones every year. Besides, for country tiles which are heavy, rather substantial scantlings of timber have to be used which go to increase the cost.

Mangalore pattern tiles are light and more durable, but they also absorb heat. Again, they are likely to be blown away by high wind. To remedy this, wooden or other ceiling has to be constructed below them which also serves to mitigate heat. A still further objection to their general use in small towns and villages is that the tiles are not locally manufactured and therefore unless a sufficient spare stock of this breakable material is always maintained, as they are liable to be broken or blown away, great inconvenience is caused, until they are fetched from cities or large towns.

Slates are utterly unsuitable for the hot climate of India. Besides, they are liable to be broken and are even more difficult of replacement in upcountry places than Mangalore tiles. Their cost also is heavy and prohibitive.

The material most suitable for cheap buildings is the corrugated iron sheets. They are light, very strong and durable. Although something has to be done to them to prevent them from being blown away by wind, and from absorbing and radiating heat of the sun, they are the most satisfactory as regards cheapness, durability, and the thorough protection, they afford from rain, if a sufficient slope is given to the roof.

Fortunately, excellent sheets are now manufactured in India by the Tata Iron and Steel Company and are offered at the same rates as those of foreign manufacture.

For preventing heat radiating from the C. I. sheets, the following are some of the remedies :—

Colours play an important part in either absorbing or reflecting heat. Dark colours absorb most and white, the least. But the latter causes a glare to the eye. Hence blending of some other colour in white, so as to make it either grey or brown or chocolate, is necessary. The latter matches with the colour of the bricks or tiles and is pleasing to the eye.

Ordinary white-wash made of freshly slaked fat lime and water in which 15 per cent of boiled linseed oil is mixed, forms an excellent wash for application to the C. I. sheets. It not only remains permanent but reflects sun's heat and also protects the sheets from corrosion to which they are very susceptible,

particularly near sea-coasts on account of the sea-borne breeze, in which particles of salt are dissolved.

Another remedy for the preservation of the C. I. sheets from corrosion and mitigating radiation is to apply a thin coat of neat cement with a brush, preferably after sunset so as to allow it a full opportunity to set slowly in the cool weather during night time. After about a week, another thin wash may again be similarly applied.

Recently "Aluminated Tarfelt" sheets have been manufactured by Shalimar Tar Products Ltd. It is a laminated tarfelt sheet on the top of which on one side, is stuck aluminium foil, which, it is claimed, reflects away 95 per cent of heat and makes the roof cool and watertight.

Other remedies for mitigating heat are to spread a grass matting on the top so as to leave an air space of 3 inches between. This, however, harbours rats and the mat requires to be renewed every second or third year; otherwise it rots, falls to powder, and obstructs the flow of rain-water by choking the channels in the corrugations.

Still another remedy is to cover the top with bamboo matting which is an excellent reflector of heat. If an arrangement is made to sprinkle water on the matting at intervals so as to keep it moist, radiation is effectually prevented in the hot weather season.

Asbestos cement sheets, particularly the corrugated variety and the Trafford sheets, though breakable, are very well suited to Indian conditions. Besides, they are an indigenous material. They are much cheaper than C. I. sheets.

Modern methods of insulation against heat by interposing a layer of non-conducting material such as straw, weeds, loose coir, rockwool, etc., or by a curtain of aluminium or copper foil ("Building paper") on optical principles, are discussed in detail in the author's, *Modern Ideal Homes for India*.

Wooden ceiling fixed below the C. I. sheets so as to leave an air space of at least 3 inches is also a good remedy to check radiation of heat. To prevent rats harbouring in the space a batten may be nailed at the edges of the space at eaves.

A few remedies for preventing the roof from being blown away are suggested below :—

The simplest and most rational is to provide sufficient apertures just below the eaves on both sides of the house so that the wind should enter through them on one side and pass through those on the opposite. Generally what happens is that the wind striking horizontally against the wall changes its direction and applies a lifting force below the projecting eaves. Once the

eaves are lifted up, the whole roof is blown away. If such apertures are provided, ordinary precautions taken against the roof being blown away are sufficient.

Another way is to lay tiles over the roof just for weighting it. But if 2 inches by 1 inch battens from ridge to eaves, 2½ feet apart, are nailed on top of C. I. sheets and above them again usual battens are fixed to the latter across at right angles, and Mangalore tiles laid over the latter, not only are the sheets weighted but the 3-inch air space provided between, serves to reduce the radiation to a great extent. There is one objection to this method, viz., that the hollow space is likely to harbour rats. But, if brick-bats are laid in cement mortar on top of sheets near the eaves or battens nailed there and end tiles laid on them, there remains no passage for rats to enter.

If country tiles are to be used for weighting, give a generous coat of coal-tar to the roof surface, spread hay or straw on it and lay the country tiles as usual. The tiles at ends must be securely pressed by means of a long piece of flat iron, or teak batten, bolted to the sheets to prevent the tiles from sliding down the slippery surface of the straw. This very effectually prevents radiation of heat.

There is again the usual elaborate method of fastening down the sheets at the eaves and gables by continuous lengths of a steel flat or a steel wire rope fixed by bolts embedded in the masonry at about 4 to 6 feet intervals. These bolts should be 1½ feet in length and anchored into the walls by means of 6 inches square iron plates.

It is necessary to punch the holes in the C. I. sheets neatly with a sharp cold chisel. Otherwise they are likely to be torn asunder, causing leaks. The carpenters who do this job are generally very careless and must be vigilantly watched. Similarly, they often fix the galvanised screws by hammering on their heads just to save their own labour. This makes them loose. First, a hole of a smaller diameter must be drilled in the wood and then the screws must be fixed by means of a screwdriver.

If some 2 inches of cement concrete is laid over the C. I. sheets, the roof is weighted against being blown away and in addition, the radiation of heat is reduced to a certain extent. If this is done, care should be taken to lay the concrete in the evening. Otherwise by the heat of the sun, it sets so quickly that ramming becomes impossible.

The second point to be noted is that unless some sort of reinforcement is used on the top of the concrete just in the lengths, where C. I. sheets are supported from below by purlins, cracks are sure to develop. To prevent this, wire gauze netting even of 1 inch mesh in strips of 12 inches width may be embedded about ½ inch below the top of the concrete, parallel to the purlins.

The cracks are unimportant from the point of view of leakage or structural strength. But they form an eyesore.

### No-frango Roof

As a roofing material, for temporary buildings, No-frango has great possibilities in tropical countries like India; because, on account of the elasticity it possesses, which is due to the hessian (jute) fabric embedded in it, it is least susceptible to form cracks on account of the temperature stresses.

The construction of the framework is similar to that of Mangalore tiles, the only difference being that the battens required for the Mangalore tiles are not required for the No-frango roof.

Even a thinner section of rafters would do as the No-frango slab is not more than one inch thick and is much lighter than Mangalore tiles. Hessian fabric, as wide as available, may be soaked in water and stretched from one end to the other, an overlap of 6 inches being given at the joints which should be stitched either with hessian, twisted yarn, or thin steel wire. Instead of stretching the whole piece from one end to the other, better results are obtained, if the portion from one rafter to another is stretched and fastened by means of tacks. This may again be soaked in water and a grouting coat of mixture of one of cement, and two of fine sand, should be applied by means of a brush. When this sets, but is still wet, the usual coat of cement and sand mixed in the proportion of 1 to 3 should be screeded on to it and the surface rendered smooth by means of a float. The surface is bound to be uneven showing ridges over the rafters and furrows between them. This is, however, an ideal condition, because so many channels for draining off rain-water are automatically formed, and the corrugations increase stiffness.

It is necessary to take particular care in respect of watering the roofing slab in the tropics. Unlike ground or suspended floors it is exposed to sun. On account of the fabric being stretched well, the excess of water drains away and hence, if special care is not exercised it may get quite dry before it sets and obtains sufficient strength. Saw-dust may be spread on the top to retain moisture.

This sort of roof is ideally suited to buildings of temporary nature, as it is light, water-proof and cheap. As the hessian is likely to rot, it is not recommended for *pucca* types of buildings.

### Some Practical Points and Hints for Economy in Pitched Roof

(1) A wall plate is supported by the wall below, throughout its length and therefore, is not subjected to stress like a beam. Its functions are, firstly, to distribute the pressure of the roof uniformly on the wall and secondly, to make a junction between the roof and the walls below. Hence, they need not be of such heavy section as 4 inches by 5 inches or 4 inches by 3 inches as is

th

commonly done. Even 2 inches by 3 inches will do. Concrete bed-plates will also serve the purpose equally well. Even round rafters which are cheap will do.

- (2) Instead of one heavy verandah post of, say, 6 inches by 6 inches, if two pieces say, of 4 inches by 3 inches or even 4 inches by 2 inches are joined by cross-pieces and laticing is done as shown in Fig. 40 to form a compound pillar, not only is its strength increased, but they can either be spaced at longer distances apart or the depth of the post plate may be reduced. Such sort of pillars also look more elegant.



Fig. 40.

- (3) It is unnecessary to plane timbers which are likely to remain hidden from view, e.g. wall-plates; and if a horizontal ceiling is constructed, all roof timbers may be left unplanned.

- (4) Alternative rough estimates should be made to see which of the two—horizontal or sloping—ceiling is cheaper. A horizontal ceiling looks well and is better for prevention of heat as it encloses more air space and also requires less boarding but a heavy framework is required to suspend it.

- (5) Ends of C.I. sheets should never be embedded in masonry.

- (6) Very often an oil paint does not stick to new C.I. sheets or, if applied, it cracks and comes off in curly flakes. This should be remedied by washing the surface with washing-soda or the paint should be applied, after the sheets are exposed to weather for a few months.

- (7) If it is intended to cover the C.I. sheets with tiles, and if the latter are of good quality, considerable economy may be effected by overlapping even half a corrugation as shown in Fig. 42. If no tiles are to be laid, then  $1\frac{1}{2}$  corrugations, must overlap. (Fig. 41.). The end overlap must be 4 inches and if the slope of the roof is small, 6 inches.

Fig. 41.



Fig. 42.



- (8) Instead of lead washers, which are costly, if pieces of strong cloth soaked in asphalt are wound below screw-heads to form washers, they are cheaper and more watertight.

### Flat Roof

Unless perfectly water-proof materials like bitumen or asphalt are used at considerable cost, flat roofs cannot be expected to afford absolute protection in the hot climate of India. They necessarily require some sort of parapet wall and as the gutter, collecting the rain-water on the surface of the roof behind the parapet, is just on the top of the wall below, any small cracks—

even hair-cracks—in the gutter cause the water to descend directly into the wall below.

The merits and demerits of the flat roof have been already discussed in the preceding chapter. There are various methods of constructing flat roofs, according to the climatic conditions, materials available, and the local practice of the different places. The cheapest form used is that of round ballies nailed on two wooden beams to span the space across them, over which, are laid some sort of reeds or wattle or long twigs of trees, such as *Sarkand* or *Samalu* in Northern India, or *Karvi* or palm leaves in the Deccan and Southern India.

On the top of these is spread a 6-inch layer of stiff mud which is beaten hard ; if the mud is not of earth which is non-absorbent, special non-absorbent earth (*Khari Mitti*) is brought from a long distance and spread loosely in a layer of about 1 to 2 inches. The wattle is sometimes replaced by timber-waste obtained from saw mills, which is nailed to the rafters.

At some places, better class people use mild steel T-pieces, which are inserted and laid in an inverted position, one foot apart, and special roofing flat tiles, 12 inches by 6 inches by 2 inches (usually) are laid on between the flanges of the T-pieces, and over these, mud and loose earth are spread as above.

The top surface of flat roofs must be suitably sloped, the exact degree depending upon the local circumstances, such as the rainfall, and the quality of the clay available.

The water-tightness of such roofs depends entirely upon the quality of the earth used. At certain places it is an extraordinary thing, that though such roofs crack badly during hot weather, when it rains, the cracks are automatically filled up by the loose earth carried by the rain-water passing over them, and the roofs are rendered perfectly water-tight in spite of heavy rain.

Such roofs, however, need careful attention both in the beginning and at the time of subsequent repairs, and where good earth is not available, they are sources of considerable trouble and inconvenience, and sometimes of danger, if the walls are of earth, or even of brick or stone in mud mortar. Again, in places where trouble from white ants is feared, the timbers have to be renewed at short intervals.

If C. I. sheets are used instead of the reed or wattle and the roof made as usual with a layer of good quality of earth, not only an absolute protection from rain is obtained, but the covering of the earth removes every fear in respect of both, the roof being blown away by wind, and heated by the sun. Of course, the necessary slope must be given to the surface. An additional advantage in respect of cheapness given by this sort of roof, is that as the incline is small, fewer sheets are required than for the usual sloping C. I. sheet roof

and that the stiffness caused by the corrugations saves a considerable amount in timber supporting them, as the spacing apart of the latter can be safely increased. If mild steel rolled sections are used for purlins, the roof becomes fire-proof and practically a permanent structure.

Before laying the sheets in position, they should be given two coats of bitumen with a brush; this would prolong their life. In order to make mud roofs water-tight, the remedy suggested for making exposed surfaces of mud walls water-tight on page 50 may be tried with success.

### Concrete Terraces

Concrete terraces, whether of lime or cement concrete, must have a rigid base. Even a slight movement in it, whether due to mechanical agency or to expansion and contraction caused by heat or cold, causes the concrete above it to crack and through the cracks, water leaks. Wood is therefore, quite unsuitable as it swells by moisture and as a result expands and then contracts again considerably. Iron and steel in the form of rolled sections are much more preferable, as they are not much affected by weather and behave as much more rigid material than wood.

The upper concrete layer in terraces is carried on either jack arches or on tiles or stone flags, etc. The tiles or slates are laid on steel or wooden joists. The concrete is made of  $2\frac{1}{2}$  parts of the broken brick-bats, one part unscreened sand and one of lime mortar. The pieces of brick-bats are allowed to soak in water freely for 2 or 3 hours before mixing. The concrete should be laid in a stiff state and beaten well. During the process of beating, the surface should be sprinkled with water, in 8 *gharas* or 6 kerosene oil tinsful in which, is dissolved 3 seers of molasses and 2 seers of *beal* fruit. The success in respect of compactness, which is synonymous with water-tightness, depends upon the thorough consolidation made. This should be done by beating for three days and should only be stopped when the rammer rebounds and a heeled shoe cannot make a mark on it. Clean water should then be freely sprinkled and when the cream of lime at the surface is softened, the surface should be rendered smooth by polishing with a trowel. No fresh mortar or cement should be added, as it forms a skin layer which soon swells and forms hair-cracks.

In order to render a terraced roof quite water-tight, the surface of the concrete should be coated with hot bitumen and over it should be laid, flagstones or tiles, filling the joints with cement mortar.

Another method of making a water-tight terraced roof is to lay on top of lime concrete flagstones of as large a size as practicable so as to minimise the number of joints, which form the only weak spots. When paving stones are laid, the joints of the slabs should be kept  $\frac{3}{4}$  to 1 inch wide and they should be raked out to their full depth and filled in again with cement mortar consisting

of one part of cement and two of fine sand. The idea is that if leaks occur at all, they will do, through the joints only, which, in the first place are much less in number, and again, have received a special treatment with cement mortar. Hence, the chances of leaks occurring are fewer. However, if they occur at all through some of the joints in course of time, through hair-cracks formed in them, it is a simple matter to open them by a chisel and fill in asphalt or some other water-proofing material and end the trouble once for all, at a small extra cost. The purpose of keeping wide joints is that they should admit of a chisel being used for opening them. As an alternative the joints should be made  $\frac{3}{4}$  in. wide, raked out and filled half of their depth with hot asphalt or bitumen and the upper half with cement mortar.

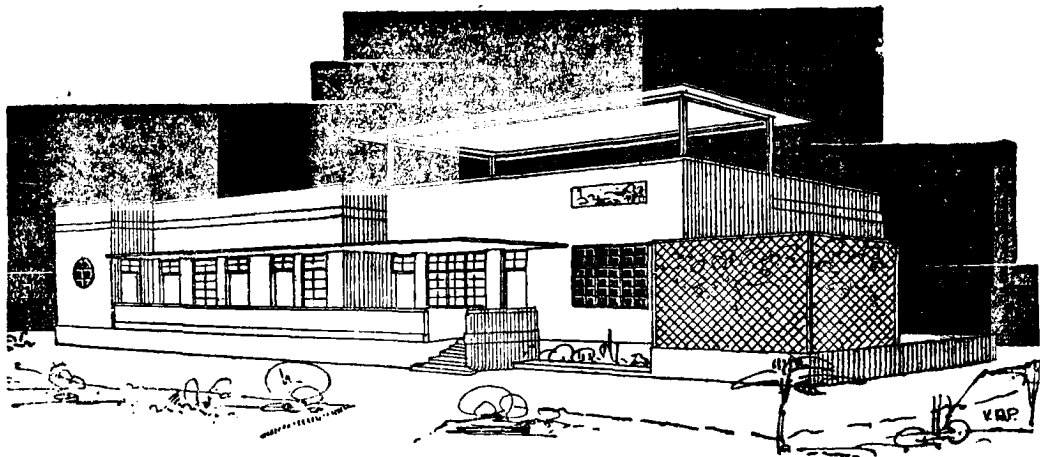

## Domestic Sanitation : XII

The fundamental principles underlying perfect domestic sanitation are enunciated below :—

(1) All refuse and waste matter, whether solid, liquid or gaseous which is offensive and injurious to health, must be removed away from the house, as rapidly as possible after it is produced and disposed of in such a way as to render it harmless.

(2) No part of the house should hold damp anywhere.

(3) All substances which are of such a nature as to absorb, catch, carry, hide or retain particles which are likely to hold germs of diseases, must be avoided as far as possible whether employed in the structure of the building itself, or in decoration and furnishing ; thus porous and absorbing bricks, sea sand impregnated with salt, which absorb moisture, are bad. Thatch for roofing, which is sure to decompose, is bad ; stone carvings, embossed plasterings, mouldings, ornamental railings, cotton or woollen fluffy carpets, etc., which are likely to catch, hold or hide dust, are bad.

(4) Every room of the house must be provided with adequate means for admission of fresh air and expulsion of used air, so that it is continually charged with a stream of fresh air.

(5) Every part inside the house, including every nook and corner, should be fully lighted as far as possible, by the direct light of the sun.

(6) The house should be supplied with a copious supply of pure water.

Let us take these in order and see how they can be enforced to suit the peculiar conditions of India, caused by the habits, customs and religious prejudices of the people.

All refuse matter may be divided for the sake of convenience into two classes :—

(1) Matter of fæcal or excremental nature, both human and animal.

(2) Other waste refuse, such as straw, ashes, waste papers, rags, garbage, etc.

The first is of the greatest importance, because if it is not efficiently removed from our surroundings, it soon decomposes and the germs of diseases,

such as would cause Infantile Diarrhœa, Dysentery, Cholera, Typhoid, etc., are disseminated by flies and dust reaching the eyes, food, milk, and water.

The only satisfactory means of efficient removal, especially of fæcal matter, is the water-carriage system with underground drainage. It also simplifies its disposal. But India is so backward and poor, that whereas the system prevails in all towns and many of the villages in the Western countries, not more than two dozen cities in the vast continent of India, can boast of it. In villages and small towns there are often no Municipalities at all. There are therefore no sweepers and scavengers to remove the filth from premises of houses, which are used by young children and often by women in *pardah*, for answering the call of nature! Others do so in and around the village site, wherever some privacy is afforded by shrubs, mounds or banks of earth, stone quarries, etc. The fæcal matter is allowed to decompose and dry, during which period it attracts swarms of flies. It is then constantly stirred up under feet of cattle and men, and when reduced to powder, is blown away by wind to be deposited on water and foodstuffs and to be inhaled into lungs.

Even the cities and towns blessed with Municipal organisations, are not a whit better. In the first place, more than 50 per cent of the houses have no latrines of their own, with the result that the same conditions as those described above prevail, perhaps in a worse degree, because the houses being crowded, and there being no open space available round them, the streets are made use of, any time by day by children, whom their age gives a privilege in respect of privacy, and by grown-up people, during the small hours of the morning or after dark. The free public latrines provided by Municipalities are either inadequate in number or the people are so slovenly in their habits that many of them do not take the trouble of walking a few steps to take advantage of them. Even where latrines are built, the open drains of the street receive the contents of the overflowing baskets in the latrines; the semi-fluid matter stagnates in the gutters and forms a breeding and feeding ground for the flies and mosquitoes. The habits of some people are so bad that even the most enthusiastic and conscientious sanitary inspector, though backed by the authority of law, soon becomes disheartened in his thankless task and loses much of his efficiency.

Poverty, and ignorance of the most fundamental principles of hygiene, coupled with conservatism and religious prejudices, are some of the causes. The only remedy is education by proper methods, such as popular lectures with the aid of lantern slides, health exhibitions, broadcasting leaflets, posters, etc., by volunteer organisation rather than by authority. If a band of enthusiastic volunteers in each village or town goes on rounds and by actual example rather than by precept shows how to clean the town or village, wonders would be worked out in a short space of time. The author had actually organised

such a volunteer corps and he writes from personal experience. Enthusiasm is never wanting in youths and if under proper guidance, they are taught to clean up with their own hands the stink left by insanitary householders and if they have once absorbed the spirit of social service and do it wholeheartedly, not only would those responsible for the filth be put to shame and taught a lesson, but the gospel of the dignity of labour and social service would be brought home to them in a more telling manner against the age-long habits and religious prejudices, than by any amount of effort made in all other directions.

Really speaking, in villages and small towns, where there is generally some elbow room, at least in the rear yard of the house, the problem of dealing with the sewage produced in the individual homestead, should present no difficulty. But unfortunately, a strong determination and an earnest desire to solve the problem is lacking on the part of the people.

It is not possible to give in the short compass of this book the various types of latrines and to describe the various methods of disposing of sewage; this has been attempted at some length in the author's other book.\* It is proposed to describe here only a very simple and cheap method, suitable for town areas, where there are municipal scavengers, and for the others, suitable for rural areas, the reader is referred to the author's booklet mentioned in the foot note.

The conditions which an ideal latrine must satisfy are :—

- (1) That it should not give out noxious smells.
- (2) That it should not attract flies and other vermin.
- (3) That the contents should not be visible to the user.
- (4) That the night soil and the liquid contents should either be removed away from the site at the earliest opportunity for disposal, or suitably treated so to render them innocuous.

<sup>1</sup>Let us see how far the two types to be suggested below satisfy these requirements. To take the one, which is suitable for municipal areas first :—

Figs. 43 and 44 show a simple design of a latrine which does not differ from the ordinary ones, usually constructed in municipal areas, where the night soil is collected in baskets and removed to a distant place by sweepers.

---

\* *Disposal of Domestic Sewage and other Refuse* by R. S. Deshpande (Rs. 3/-).

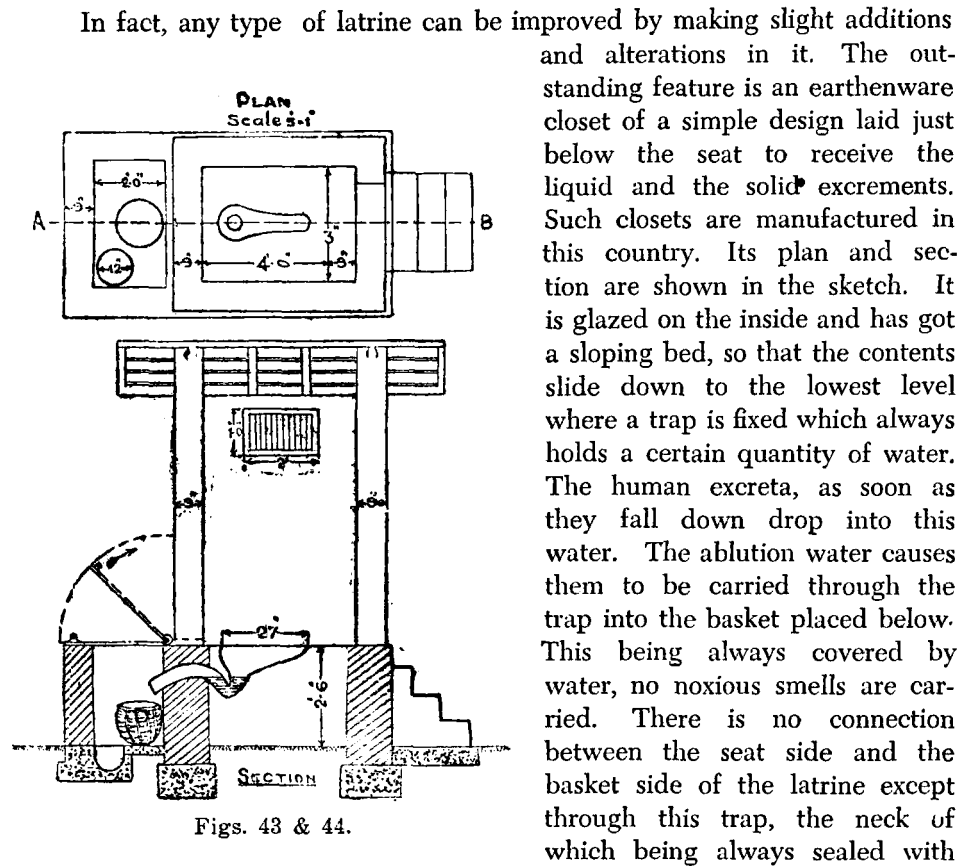

There is a small rear chamber of burnt brick in lime with inside dimensions of 2 feet by 3 feet. Its bottom and sides are lined on the inside with cement plaster and there is, in one of its corners, a small pit or sump, also lined on all sides with cement for holding the liquid contents. The bed of the chamber is made to slope towards this pit. The chamber has a cover of galvanized iron sheet at top. The contents of the closet above, fall into the basket provided with a fairly deep layer of fine coke breeze, mixed with ash, so as to act as a kind of filter. Failing this, sand or porous earth may be used. In these cases, the fæces will lie on the surface of the material and be very readily and cleanly removed. The basket should have numerous small holes in the bottom, if it is of metal sheet, so that if any liquid filters through coke breeze or sand, it will flow into the sump. The sweeper has to lift the lid, remove the basket with its contents, scavenge the floor, remove also the liquid contents of the pit, put the empty basket in position and replace the cover

before he goes away. The efficiency of this arrangement is due to the following facts.

(1) As the chamber is always covered, there is no chance of flies sitting on the filth.

(2) The solid contents, separated from the liquid, remain dry and do not readily putrefy and can also be easily and cleanly removed.

(3) The liquid as it filters through a layer of coke breeze or sand, does not give out much foul odour.

(4) The whole thing remains quite clean and hidden from view. An occasional coat of coal-tar, or better still of pesterine, to the cover and the outside of the chamber is recommended.

If the earthenware closet with trap is omitted by those who cannot afford it and instead of it a simple half round 6 inch diameter earthenware pipe is fixed in a slanting position on the top of a trap, it would serve the purpose. But the closed chamber on the rear side is absolutely necessary, if flies, which transfer germs of disease, are to be excluded.

#### Prevention of Damp

We next proceed to the second principle of domestic sanitation viz. that the house should not hold damp anywhere. Enough has already been said in Chapter III about the prevention of damp while building a new house. We shall now confine our remarks to the question of how to remedy the existing one. For this, the root cause of the damp must be first found and remedied. Very often it will be found to be due to defective drainage. If it be due to the choking up of a drain somewhere, the obstruction should be traced and removed. If it be due to a very insufficient slope given to the drain, the latter will have to be regraded. It may perhaps be due to a leaky joint which should be traced and mended.

If the damp be due to a leaky roof, water from which soaks into the wall, the leak should be located and set right. Sometimes it is very difficult to find the exact spot of the leak in a pitched roof if there is a ceiling below it, because the water drops on the ceiling and finds its way somewhere else through it. If it be a flat-terraced roof with concrete on the top, a search should be made for cracks, and they should be filled with a water-proofing compound. Sometimes there is no crack distinctly visible, but there are innumerable hair-cracks spread over the surface through which water percolates. This can be remedied by giving one or two coats of a water-proofing paint such as hot bitumen.

The damp may, perhaps, be due to rain-water collecting near the house in a depression. This should be drained off, and arrangements should be

made so that rain-water runs fast away from the house before it gets time for accumulation and soaking in. The cause of the damp oftentimes lies in the mud or earth used for the flooring of rooms, containing salts which absorb moisture from the surrounding soil and even from the air. To remedy this, at least one foot layer of the earth at the surface should be removed and replaced by good earth which does not contain any moisture-absorbing salt, and the floor remade. Or, the old earth should be washed to leach out the salts from it, (see page 38).

Often, the site slopes sharply, causing the plinth of part of the house to be at lower level than the ground surface on the other side so that damp necessarily rises in the floors and walls in that part. This can be remedied in either of the two following ways :—

- (1) If the difference in level is considerable and also damp serious,

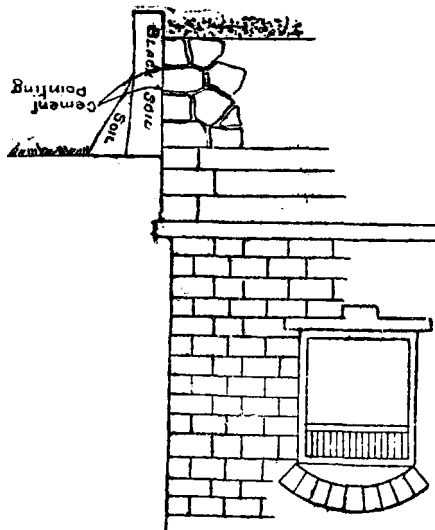

Fig. 45.

excavate a trench close to the outer wall on the side of the high ground, down to the foundations, wash the face of the stone masonry, rake out joints and point them with cement mortar, and in addition to this, fill the trench with clay of the nature of black cotton soil (*Regur*). If the clay has to be brought from a long distance, cover only 6 inches width of the trench touching the wall with it, and remaining width with the earth excavated from the trench, side by side, in 6 inches layers, as shown in Fig. 45, and ram well up to the ground surface. The black clay is impervious to water, and effectually blocks the passage of water towards the house. If the wall be built in burnt brick, the portion below ground, in which damp has appeared, must be plastered with cement before filling the trench with black clay.

(2) Another remedy is to excavate the floors of rooms to a depth of about 15 inches, remove the stuff, and fill in pebbles and gravel from river-bed, of sizes varying from 4 inches to 1 inch to a depth of 9 inches and remake the floor on top of this; this would ordinarily make it free from damp. If a layer of about 4 inches of cement concrete is laid at top, as an additional precaution, it ensures perfect protection from damp.

Sometimes, there is a large source of water-supply at a higher level, and the ground below it is permeable, through which water percolates and rises in the form of damp. Very often, a whole village is affected in this way. The

only remedy is to excavate a trench on the upper side of the house or village, deep enough to cut through the water-bearing stratum such as *murum*, sand, etc. A suitable bedfall should be given to the trench and it should be made to join a nalla or a river. The trench should be filled with boulders of stone and the top portion made good by filling earth. The trench will intercept and carry to the river the water which would otherwise have caused damp.

#### Prevention of Dust and Dirt.

We now come to the third principle of domestic sanitation viz. avoidance of dust. To what extent the atmosphere is charged with dust needs no demonstration. One can actually see the particles lit up by a beam of the sun entering a dark room in a house. How the cloud of dust rising behind an automobile running on roads suffocates for a few seconds the passing pedestrians is a matter of every day experience. Part of this dust cloud unfailingly finds its way in dry weather through every chink, door and window opening in the house walls and settles in a thick layer on the horizontal surface of every article in the house. It mingles with the food we eat and with the liquids we drink. One would be startled to find what a large quantity of dust one must be sucking into one's lungs during the process of breathing, when it is considered that an average man inhales 16.6 cu. ft. (or 33 average-sized pitchersful) of air per hour.

The street dust has become so familiar to us that we have lost the sense of appreciating the incalculable evil caused by it. Street dust when examined under a microscope is seen to be composed of powdered mud, particles of human excreta, powder of decaying bodies of dead animals such as cats, dogs, rats, etc., particles of soot, fibres of cotton, hair, etc., etc.;—all contributing their quota in forming the savoury compound called dust.

Every particle carries with it hundreds of microbes of disease. Fortunately, we are provided with a delicate apparatus in our nose which prevents even a single particle from finding direct access to the lungs proper. Otherwise, untold calamity would have been the result. The particles are driven back to the throat from where they are swallowed in the stomach. Still, they affect the throat and cause irritation; bronchitis is said to have its origin very often in dust. Sore eyes, especially of children, is another result.

Again, the dust produced by certain trades is poisonous. Thus the dust produced while manufacturing lead and arsenic paints, grinding metals, etc., is full of poison. The dust in the ginning factories is full of microscopic particles of fibres of cotton which are found to clog the passage of lungs.

If it is realised that dust and dirt mean disease, all that lies in our power must be done to minimise the harm due to the evil. There must be no recesses or ledges, no cornices of complicated designs, *no jalis*, carvings and other ornamental work, no furniture except that with plane surfaces, no fluffy carpets of wool or cotton that hold dust and yield a cloud of dust when shaken, etc. Even niches and open shelves, in which things are likely to be stowed away and left undisturbed for months together are objectionable. It is desirable even to go to the extent of making the bottoms of windows on the inside, sloping, instead of flat, to preclude the possibility of any articles being put there. For, not only do they obstruct ventilation, but are, in addition, sure to catch dust. There should be an ample provision of cupboards in walls and all of them should be closed by close-fitting shutters, no matter of whatever cheap material.

Some people are very fond of crowding the rooms with unnecessary furniture or lumber. They make the task of the housewife or servants very difficult, and if the latter are slack in carefully dusting them every day, which they are sure to be in nine cases out of ten, the articles are bound to accumulate dust and dirt.

In short, strictest attention should be paid while designing and building a house that the labour of keeping it clean would be the minimum.

#### Ventilation.

Air is a prime necessity of life which becomes extinct if the air supply is cut off even for a few minutes. In a closed room, the effect of animal respiration is doubly adverse on the air enclosed. For, when we inhale, we consume oxygen from it, and when we exhale again, we render it impure by filling it with carbonic acid gas and water vapour. Impure air causes headache and sickness, and ultimately devitalizes the person; because, with the deficient supply of oxygen, the process of purification of blood is checked. The man looks pale, loses vigour, activity and the power of resistance to the germs of disease, and thus falls an easy prey to it.

This is what exactly happens in India. The reason, why Malaria, Cholera, Plague, Small-Pox, etc., take such a heavy toll of human life in India, will be found in the most devitalizing conditions caused by deficiency of adequate light and ventilation, and prevalence of general insanitary conditions in the dingy and stuffy rooms in the house, especially of lower classes. The high death rate, particularly amongst infants and women, has its origin in the overcrowding of rooms and deficiency of fresh air and light in ill-built, congested houses. Men go out into the open air at least for some part of the day, but the females of the middle classes and especially those in *purdah*, have to confine themselves for 24 hours in the house. The young and innocent infants whose strength and power of resistance are naturally very low are further

devitalized by want of sufficient oxygen, and consequently succumb to diseases, even with a slight change in the atmospheric conditions.

In many towns, the depth of houses, front to back, is excessive and the houses in most cases touch each other with the side walls in common between the two. In rare cases, where a small passage or gully exists, it is generally not more than 2 feet in width which is quite inadequate to supply fresh air and light to rooms; on the contrary, it is so full of filth and decomposing matter thrown from windows on either side that to exclude the foul gases, the windows have to be normally closed. As a result of this the buildings are deficient in ventilation and light, the central rooms being often in absolute darkness, requiring a candle to light them when required even by day. They are dependent for ventilation upon the passages within the house.

In villages and small towns, one or two small square holes, scarcely exceeding one or two square feet in area, are provided in the walls, even though the entire wall surface may be exposed to light. These holes are also closed by night for fear of draught and burglars, sometimes by permanently fixing gunny cloth by nails against the closed shutters, and in the small space enclosed within the walls, all the members of the family sleep on the ground by night. It is a common practice to allow in the same room calves, goats, poultry, the latter covered under a loaded wicker basket. Were it not for the chinks in the ill-fitting doors, and the crevices in the crude form of the tiled roof, through which some air enters, they would certainly die of sheer suffocation. Nevertheless, the bad effects must be there, especially on the health of infants.

The remedy consists in educating the public mind in domestic sanitation and personal hygiene by every means possible. Aid of legislation, if possible, may be taken in the beginning.

With this slight digression for which no apology is required, let us turn to the subject in hand. Ventilation connotes much more than mere providing of fresh air. The old theory that carbon-dioxide ( $\text{CO}_2$ ) is a poisonous gas, and that if its proportion in the air exceeds a certain limit, it proves fatal has been exploded. It has been recently proved by experience and experiments that it is not a poisonous gas, and that breathing of air containing percentages of  $\text{CO}_2$  which at one time would have been thought dangerous, has practically no injurious effects. On the other hand, it is now held in scientific circles that the more important factors, in rendering the air impure, are the organic matter continually given out with exhalation of breath and the humid emanations proceeding from the skin surface. One can verify these facts if one only brings to one's mind how foul the matter deposited on teeth is, which is nothing but a part of what comes with human exhalations, and how offensive the smell

of clothes, worn for a long time is. Thus not only the respiratory organs but the whole body is continually breathing. There are also other factors, viz. the heat produced by warm breath and water vapour contained in the exhalation, which increase the temperature and humidity respectively of the air in a closed room ; because, upon them wholly depends the sensation of stuffiness or otherwise which one usually experiences in a crowded place. When we enter, for instance, an occupied railway compartment with windows closed during night, the warmth experienced is due to the rise in temperature of the air ; the bad odour is due to the organic matter in the form of microscopically small particles emanating from breath and skin surface of the occupants ; the perspiration caused is due to the excess of water vapour present in the air, and the general uneasiness experienced is due to the deficiency of oxygen and all other above-mentioned causes combined together.

Movement of air or lack of movement of air is conducive to a feeling of well being or discomfort, leading in the latter case to serious results. Lack of movement of air leads to increase in temperature, increase in humidity, which lead to hindrance of evaporation from the body surface, heat accumulation and finally heat-stroke.

Despite the fact that the purpose of ventilation is the promotion of a healthy and comfortable atmosphere in our rooms, the latter is often deceptive. The ventilation of a room may produce an agreeable and pleasant sensation to an occupant, and still the condition of the air in it may be far from the standard sanitary requirements. The sensation of the pleasantness or oppressiveness depends upon the relative temperature and humidity of the air and also on the physical conditions of the occupant. A man who has just taken a brisk exercise may find the air in a room with good ventilation to be quite stuffy ; which a man in health at rest may find quite agreeable, but which to a third anæmic person, causes a sensation of draught in the same room.

The composition of average air is as follows :—

Component	Parts Per 10,000	
	Fresh air	Respired air
Oxygen ...	2,026	,620
Nitrogen ...	7,800	7,500
Carbon-dioxide ...	4	400
Water vapour ( variable ) ...	150	500
Dust and other impurities ...	( variable )	( variable )

Though according to the theory of ventilation the presence of a small excess of carbon-dioxide is not viewed with apprehension so far as its injurious effect on health is concerned, still, its proportion is taken as a guide for the computation of the standard requirements. With its rise in a certain system of ventilation, the proportions of the injurious bacteria in the form of the organic matter and water vapour also increase, and the oxygen contents proportionally decrease. Hence, certain limiting proportions of carbon-dioxide are taken as a basis for designing standard requirements of ventilation which are, from 5 per 10,000 parts in hospitals, 6 or 7 in residential buildings, to as much as 10, in theatres and public halls, which are crowded for a short length of time.

On the basis of this and on the assumption that an average man gives out 0.6 of a cubic foot of carbon-dioxide per hour, it is easy to calculate that 3,000 cubic feet of fresh air must be supplied per man per hour. If the room he occupies be 10 feet by 10 feet by 10 feet the air in it must be renewed three times an hour. This is, however, not strictly correct. It is not practicable to change the air completely.

It was held a few years ago that the outlet openings must be larger to cope with the larger volume of air, expanded by heat. But according to the modern sanitary opinion, if this is done, reverse currents are produced ; therefore, it is urged to provide larger inlets.

A considerable fetish is made by sanitary authorities in the Western countries of draughts. So far as cold climates are concerned, it is all right because there is a considerable difference between the temperatures of air inside and outside their houses. The outside air is very cold and the inside air heated by fire-place, is hot. Hence, the effects of draughts are immediately felt. Here in India, however, the difference is much less. Hence draughts need not be so much feared while contemplating the provision of the means of ventilation.

From the foregoing discussion, it will be seen that ventilation consists in setting up movement in the air so as to induce circulation between the fresh air outside and the used up air inside with the ultimate object of either diluting or removing the impurities and, at the same time, producing air conditions which ensure comfort to the body.

This is effected in one of the following three ways :—

(1) By taking advantage of the law of nature viz., a motion is started by particles made light by heat, rising to the top to be replaced by heavier ones sinking to the bottom.

(2) By atmospheric winds or air in motion.

(3) By mechanical means of artificial ventilation, such as fans or pumps which either extract air from a room or force it into it under pressure.

In residential buildings, the first two methods are employed. In the tropical climate like that of India, where except perhaps on a few hill-stations and during winter at some places on the plains, no fires are lighted inside the rooms, the difference in temperature of air inside and outside of rooms is not much. On the other hand, there is almost always some wind blowing. Hence, the action of wind is the main factor to be depended upon in the regulation of ventilation. This is often rather an uncertain factor. For whereas during a high wind especially in cold weather, a draught is likely to be produced, on still days, when the movement of air is negligible, a sensation of stuffiness is sure to be experienced. Hence, the scheme of ventilation must be so designed that even on days of dull atmosphere, when the motion in air is practically nil, sufficient air-exchange between outside and inside of rooms should take place through the window space provided, and when, on the other hand, there is a high wind, the draught can be prevented by partially closing the windows, as necessary.

While providing window openings for ventilation in residential buildings, the habits of the people who are to occupy them must be taken into account. Many people, especially the illiterate ones of the lower classes, are in the habit of closing all the windows or even further sealing them by tacking gunny cloth on the closed shutters. For such houses the ventilation must be fool-proof, i.e. additional openings of such sizes and at such places should be placed that even though the windows are closed, the former will normally charge the room with sufficient fresh air. Sky ventilators in the roof, clerestory windows, bulls' eyes, floor ventilators are some of the suggestions for this. If the last-named openings are to be provided, they should be done judiciously so as to avoid a direct draught on the body of the people sleeping on the floor. The latter is the practice of people in Southern India and part of the Deccan. Where however, *charpoy*s are used, no special discrimination especially in the position of the floor ventilators is required. Still, such openings, intended to be kept permanently open, should be introduced at such parts of the room where, they would not cause a sensible draught.

While providing ventilation, the following points should be noted—

(1) The exhaled hot air is light, and therefore, rises to the top, i.e. collects near the ceiling. If it is allowed to accumulate there for a long time, it tends to cool again and sink down towards the floor to be breathed again into the lungs. Hence it is absolutely necessary to provide exit openings near the ceiling level to remove the exhaled air as rapidly as possible while it is still hot.

(2) The scheme for ventilating a house should be so designed that the fresh air entering through the windows or other openings on the side of the house in the direction of the prevailing wind should pass through the opposite side. This means that the rooms shall have all the ventilators in direct

communication with the outside air space. Verandahs are considered as outside air. This is called "Through Ventilation." For the successful operation of it, windows must be provided also in the internal walls abutting against verandah specially meant for ventilation, though they might admit borrowed light also. For the sake of privacy of the rooms, it may be desirable to place them high up near the ceiling.

(3) Always remember that while overventilation is harmless, under-ventilation is a positive evil. For the climatic conditions normally prevailing in India, rules of ventilation framed to suit the conditions of the Western countries are of no use. *We want more free ventilation. Draughts need not be feared so much by a person in health in this country.*

(4) The area of inlet openings should be 20 to 30 per cent in excess of the area of the outlets.

(5) Although carbon-dioxide diffuses into the fresh air admitted more or less freely, the organic emanations from the breath and skin surface do not. They hang about in corners and near ceiling where obstructions to a free flow of air are met with.

(6) If provision of ventilation is based on the capacity or the cubic contents of a room, the tables, sofas, movable wardrobes, etc., which reduce the capacity must be taken into account.

(7) It is a fallacy that because a room is high, it must provide efficient ventilation. For the latter, the openings or orifices must be dotted, here and there, over the entire exposed wall surface. Otherwise, on a still day, the respired air diffuses in the large volume of the air in the high room, which causes it to cool down, and thus tends to check the circulation between the inner and outer air. However, a lofty room is to be preferred to a low one in hot countries, first, partly for the reason that it contains more volume of air; second, to prevent radiation, or rather minimise radiation of heat from the ceiling, also keeping the room cool. The statement often found in English books on ventilation that a height of over 14 feet is of no value for ventilation is also partly explained by the fact that ventilation and heating in such cold countries are inseparable, and there is always much difficulty in heating adequately rooms higher than 14 feet with consequent trouble with ventilation.

### Light

We now come to the fifth principle of Domestic Sanitation, viz. providing ample light in the entire house and dispelling darkness even from nooks and corners. The importance of light cannot be stressed too much. It is ingrained in every healthy mortal to love light. An infant, before the age of reason, instinctively loves light and abhors darkness. Even those having sedentary habits and unfitted for an outdoor existence, prefer well-lighted and cheerful surroundings to darkness and gloom. Light, life and laughter synchronise, so do

darkness, depression and death. Darkness is the symbol of sin. Darkness is sought by criminals for the perpetration of sinful acts. Light is indicative of piety and purity.

Even plants become pale, droop and ultimately die, if they are deprived of light—instinctively they turn to light. Similar is the case of human beings. Those who are doomed to spend a considerable time in darkness, grow pale and anæmic, lose vitality and the power of resistance to disease.

The sun's rays are the best disinfectant. Even the diffused light of the sun has this power though to a less degree. It has been proved that direct sunlight will kill even virulent bacilli of typhoid within  $\frac{1}{2}$  to 2 hours, and diffused light, within about five hours.\*

The visible light rays of the sun are, as is well known, composed of seven colours. At one end of these is the red and at the other, the violet. In addition to these, there are invisible rays—those at one end are called infra-red, and those at the other ultra-violet. The infra-red include the invisible dark rays of heat. The ultra-violet rays are very powerful in destroying bacteria and possess therapeutic value to a remarkable degree. The cells of the skin and corpuscles of the blood, circulating in the veins and arteries close to the skin surface, absorb these rays, and as a result, the blood is purified and its circulation accelerated, which causes a feeling of vigour and health to be experienced.

Dr. Rollier of Switzerland has, of late years, proved beyond all shadow of doubt, the wonderful healing power possessed by the sun's rays, by treating successfully hundreds of cases of tubercular affection, which were declared to be beyond hope of cure by the usual means. He has built special sun-pavilions called "Solaria" ‡ on the top of a hill, at Leysin, Switzerland, with special means of regulating the intensity and dosage of the sun's rays.

These rays are absorbed by the water vapour, smoke, dust, etc., present in the atmosphere. Hence, it becomes often difficult to make full use of the sunlight as a therapeutic agent, especially in crowded cities. Again, many countries in Europe, as for example, England, are not blessed with sunshine for any considerable period of the year. Hence ultra-violet rays are produced artificially by passing electric current through mercury vapour or by some such suitable devices; but the expense is pretty high. In India, however, we are blessed by Providence with so much free sunlight almost all the year round. Hence, there should be no necessity, especially for those who cannot afford it, of resorting to the artificial means of producing ultra-violet rays.

The ancient custom of anointing the body with cocoanut or mustard oil and basking in the sunshine has almost sunk into oblivion with the advance

---

\* *Hygiene and Public Health* by B. N. Ghosh.

‡ There is such a solarium built at Jamnagar in Saurashtra. It can be rotated to admit or exclude sun's rays as required.

of modern civilization. But it possesses a good many virtues to commend itself for a revival, especially for the benefit of the young children, particularly suffering from rickets, which are wonderfully cured by exposure to sun's rays or ultra-violet rays. The anointment with oil serves a treble purpose. Firstly, the vigorous massage, which is usually done with the application of oil, tends to accelerate the circulation of blood ; secondly, the oily surface prevents sunburns by reflecting away the heat rays, and thirdly, it absorbs the ultra-violet rays.

"The sun's magic rays heal all that they come in contact with. They repair broken-down bone tissue ; they dry up running sores and ulcers and cause new skin to grow over ; they cause swellings to subside ; they alleviate pain ; they bring down temperature, diminish the drenching sweats and decrease cough. The sun is the greatest of all natural healing agents in consumption."\*

The foregoing facts, specially mentioned rather in detail, will convince the reader of the vital importance of natural light on the health of human beings ; therefore, a house should be so built that every room should receive the sun's rays in some part of it, some time or other during the course of the day ; and there should be no corner in the entire house which is not sufficiently lighted. Darkness is synonymous with dirt. If a room is generally dark, it is sure to be dirty. Even in a room lighted moderately well, the darkness in the corners and recesses is sure to conceal dirt and dust. A housemaid's broom is bound to fail, in its circular sweep in corners, to penetrate into the depth of the recesses to clear the dust and dirt away. All sorts of visible vermin and microscopic bacteria breed there with unchecked activities as the darkness envelops them. If on the other hand, there is light in such corners and recesses, it makes the dirt visible and none but the most careless person will consciously allow it to accumulate there.

---

\* Dr. Edward Parisky, M.D., Brooklyn, New York, by acknowledgment to 'Health' September 1934.

## Disposal of Sewage in Rural Districts : XIII

As compared with crowded towns and cities there is plenty of everything in rural districts—plenty of fresh air and sunshine, plenty of fresh vegetables and fruits, full of vitamins, plenty of milk and eggs and also plenty of outdoor physical work. Thus a dweller in rural area is expected to possess more strength and vitality and immunity from diseases than the city dweller. But what do we actually find? The life in villages is more uncertain due to the frequent ravages of epidemic diseases, mostly carried and spread by bacteria. This is due to lack of sanitation, particularly in respect of the neglect of disposal of human and animal waste. Cholera, Typhoid, Dysentery and Hook-worm owe their origin entirely to intestinal waste matter, carelessly allowed to rot and dry in proximity of dwellings. The germs of the first three diseases, *viz.*, Cholera, Typhoid, Dysentery are actually swallowed either with food or water. Hundreds are the ways in which this is unwittingly done. For example, flies sit on the rotting filth and then settle on food with their feet full of dangerous bacteria. The germs may be carried to the sources of water supply either directly or by infiltration of sewage through soil saturated with it. The dry excreta might also be crushed under feet, blown by wind in the air and settle on the surface of food, bazaar sweets, water or milk as dust and find a direct entrance to human intestines.

The fourth disease, *viz.*, the hook-worm grows in the intestines of human beings and its eggs are thrown out in enormous numbers in excreta. One worm produces about nine thousand eggs per day.

The worm develops into the larvæ stage in warm, damp earth. When persons walk barefooted on such a ground the larvæ, which are picked up on the feet, enter through the skin into blood stream and are first carried to lungs, whence they break through into the air sacs, pass up into the throat and are swallowed. Thus they finally reach the intestine, where they develop into the worm stage. Sometimes the larvæ are directly swallowed with green vegetables eaten raw. Though the disease is not fatal, it lowers the general vitality of the victim who then easily falls prey to other diseases like Malaria, Tuberculosis, etc.

All these are preventable diseases and they can be prevented only by perfect sanitation, particularly in respect of disposing of excremental matter in such a way as to render it harmless. The requirements of an ideal system of sewage disposal are :—

- (i) It should be cheap.

(ii) Its construction should be so simple as to be within the capacity of the village carpenter or mason to make or repair it.

(iii) It should not give access to flies.

(iv) It should not give out any foul odour.

(v) It should not cause any splashing or scattering of sewage over ground surface.

(vi) It should keep out dogs, pigs, rats, cows, buffaloes and other animals.

(vii) It should not contaminate the source of water supply such as streams, wells, etc.

(viii) It should require the least quantity of water should this be necessary either for its cleaning, dilution or purification.

(ix) It should be automatic in action. No constant attention should be required for its maintenance.

(x) It should be fool-proof and if anything sometimes goes wrong at all, it should give a fair warning before it causes adverse effects.

(i) The condition regarding cheapness is self-evident in view of the abject poverty of the average Indian cultivator.

(ii) The condition regarding simplicity of construction is obvious. There may be complicated installations constructed on strict scientific principles, but if anything slightly goes wrong, an expert will have to be called for from cities.

(iii) Regarding fly nuisance on account of the familiarity, the havoc

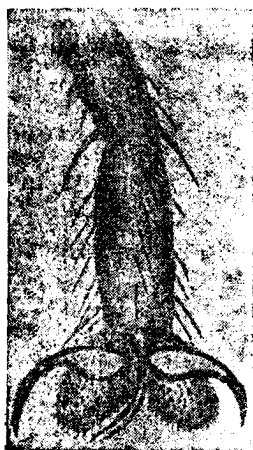

Fig. 46.  
Leg of house-fly  
(magnified).

played by the common house fly is not properly appreciated. Not only is it one of the dirtiest insects but it is no exaggeration to say that it is a messenger of Death. It is more fond of putrefied things such as fæces, blood, pus, etc., than clean sweets and dairy products. A fly cannot eat solid substances such as sugar. It, therefore, liquefies such things by dropping its saliva on it and then swallows it to its heart's content. It is so voracious that when it cannot eat any more it vomits and empties its bowels on the food and when the latter is wetted starts eating it again. It has six legs each full of thick hair growth as shown in Fig. 46 and there are two pads of hair, soft like velvet, at the bottom of each leg upon which it rests. Thus, when it sits on filth, innumerable particles of it are bound to stick to the pads and the hair, and when it settles on food in this condition millions of disease germs

are introduced into the food. Whenever filth is exposed in latrines there are

invariably swarms of flies sitting on it and these, when tired of feeding on it and want a change, enter the house directly and sit either on food in the kitchen or on the lips and eyes of infants. The germs left on the lips enter the mouth with the saliva, and diseases like diarrhoea are produced to which very often the innocent babies succumb on account of their low vitality. That is why it is a messenger of Death.

(iv) Foul odours indicate that the system is not working properly.

(v) If sewage is allowed to be splashed or to lie scattered about on the ground surface, the hook-worm is likely to spread and troubles from flies also will arise.

(vi) If dogs and other animals get a chance to eat the filth they are likely to spread disease by contaminating food or water with the filth sticking to their mouths.

(vii) If sewage be allowed to soak into the ground, the sub-soil strata are soon saturated with it and if there be a well or stream nearby, the liquid sewage may pass in course of time, unfiltered and enter the wells or streams.

(viii) There is a great scarcity of water in a large number of Indian villages. In some of them water, even for drinking, has to be brought from long distances. Hence, the condition that the system of disposal should not require any water, and that if it cannot do without it, it should need a minimum quantity is very important.

(ix) and (x) In view of the caste and social prejudices that none except a person of the sweeper class should touch such disposal installation, it is necessary to lay down the condition that it should be automatic in action and should require least attention for its maintenance.

Let us now discuss the various systems and verify how far each one of them satisfies the above requirements: The various systems in vogue at present are (1) Using open space. (2) Conservancy or Basket system and Hand removal. (3) Water carriage or Flushing system. (4) Earth closets. (5) Bore-hole latrines. (6) Trench latrines. (7) Septic tank.

(1) Using open space for answering the call of nature is the most primitive system. It was not so objectionable when, in primitive days, houses were scattered. Even then the aged, the sick and children used the premises of the house out of necessity. But gradually the grown up people on account of their slovenly habits, found it convenient to follow suit and this continued even though the houses were built close together. This has given rise to general insanitary conditions in and around villages with consequent spread of diseases. This system is most objectionable even from the point of view of

privacy, particularly, amongst women folk. Lastly, the material which would have been very useful as manure for agriculture, which is suffering for want of it, is converted into poison!

(2) **Conservancy or Basket system** :—This system has been tried for a long time and has been found to be equally bad, nay, even worse in some respects. In the first place in the areas under local authorities, more than 50% of the houses have no latrines of their own, and the public latrines, if provided at all, are too few to cope with the demand. In consequence, conditions worse than the above prevail there. For, in villages there is at least ample space round the houses, but in towns, it being very scarce, streets are made use of by young children, any time by day, and by adults during small hours of the morning or after dark. Even where latrines are built, the baskets usually overflow, the liquid sewage flows into open street gutters with swarms of flies breeding and feeding on them. The latrines themselves are very insanitary with mud walls and mud floor, which is scarcely or never cleaned. Oftentimes no paving, either of concrete or flagstones, is provided even below the basket. At some places, the basket is unserviceably broken or often altogether missing!

All this is very bad indeed, but there are still graver problems involved in it. Firstly, it is a mistake to leave the most vital question of our health to the mercy of the sweeper and to depend entirely on a class of people who do not know the value of sanitation. He does not care for the house-owner and would not tolerate any remarks from him for unsatisfactory work. Very often he sets aside the orders of his superiors, makes unreasonable demands and if they are not fulfilled, goes on strike. How often do we hear of sweepers' strikes and the sanitation of a whole city thrown into ruinous condition?

Secondly, there is a social aspect to the problem. The sweeper is a human being, made of the same flesh and blood as we. Why should he then remain perpetually in bondage, do such filthy work and remain for his whole life "untouchable" and "unclean"! He has served us all these days, badly or well, but faithfully according to his lights. Instead of rewarding him for his services with education, we have condemned his whole class as untouchable. It is a shame to us, fellow human beings! It is only in India amongst the nations of the world that a large part of the human population—several million people are selfishly held in servitude to do the filthy work. It is a curse to India and the sooner it is removed the better.

Thirdly, howsoever efficiently the system of hand removal be organised, the nuisance of foul odour and flies, while cleaning latrines, emptying baskets and carrying the sewage in carts through streets and finally emptying the carts

into trenches, cannot be avoided. It is impossible to maintain the whole system so scrupulously clean as to be absolutely harmless.

Lastly, one who has examined the municipal budget will tell how expensive it is to maintain the necessary establishment and equipment and still the result is disappointing.

(3) **Water Carriage and Flushing system** :—This is the most satisfactory

system so far known. But it requires a number of facilities, for providing which a great outlay of expenditure must be made. First of all there must be plenty of piped water supply under sufficient pressure. Then a network of underground sewers on sanitary lines must be built and thirdly, the question of the disposal of the entire sewage must also be adequately solved. If there be sea or large river with flow even in the hot weather season, sufficient to dilute the sewage, it may be introduced there, away from human habitation. This is most economical, otherwise additional large capital must be spent on pumping the sewage and distributing it for irrigation of crops or treating it suitably so as to make it harmless.

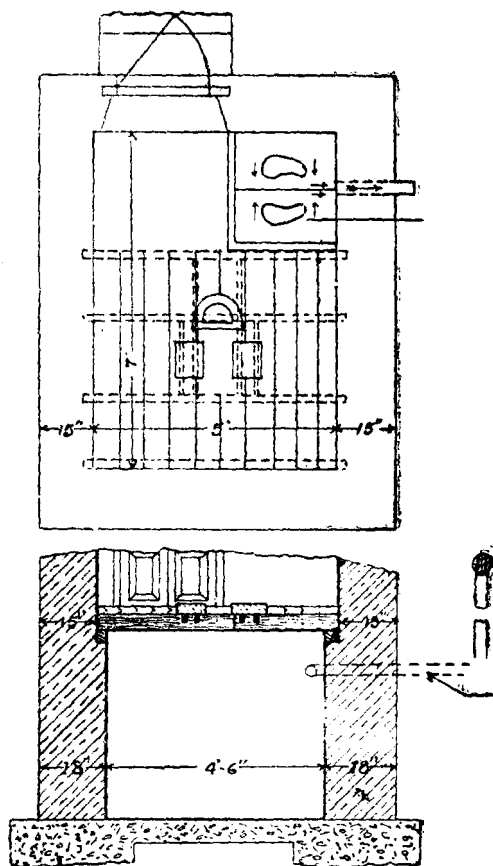

Figs. 47 and 48.

Plan and Section of Earth Closet.

(4) **Earth closet** :—In India on account of the two disabilities, viz., that on account of heat, putrefaction starts very early and that lot of water is used for ablution, the problem of earth closets becomes a little more difficult than in the Western countries.

However, if an earth closet is built on scientific lines and arrangement is made to separate liquids from the solid excreta, or at least to reduce the quantity of water to a minimum, it must give perfect satisfaction.

The type of an earth closet shown in Figs. 47 and 48 has been found by experience to give excellent results. It consists of a pit 4 feet 6 inches  $\times$  4 feet 6 inches and 4 to 5 feet deep with 6 inches of lime concrete at bottom

and 18 inches thick side walls. The pit is lined at bottom and sides with cement plaster. At the plinth level the thickness of walls is reduced to 15 inches, leaving a step or an offset of 3 inches inside all round. On this ledge, a wooden frame is placed and a rigid platform is made of  $1\frac{1}{2}$  inch boarding, leaving a gap 7 inches wide with foot rests on both sides for squatting and a suitable basin with a hole at bottom for the urine. On the front side near the right-hand corner there is a sink with foot rests with a central channel with a good slope for ablution water. As soon as the closet is used, a mixture of dry earth and ashes, placed in a pail near the seat, is to be spread by the person to cover the excreta and then the ablution should be done in the corner sink. The water from the latter is diverted from the earth closet and treated separately in a soak-pit about 3 feet deep filled with rubble stones, brick-bats, gravel, etc. and covered with 6 inches of earth at top. There is a ventilating pipe provided. But this is not absolutely necessary.

As only the urine is admitted into the pit, the quantity of earth required to treat the liquid portion is small and if sufficient quantity of it is used, there are absolutely no foul gases produced.

(5) **Bore-hole latrine** :—This is much cheaper and more convenient than the earth-closet, but its chief requirement is that there should be deep soil for the bore. Rock, *murum*, or even sand are of no use. The soil should be at least 4 feet deep ; if it is 10 to 15 feet deep or more, it is an ideal condition. Heavy clay soil (not black cotton soil, which cracks) is the best. Sub-soil water level, even in the rainy season, should be as low as possible.

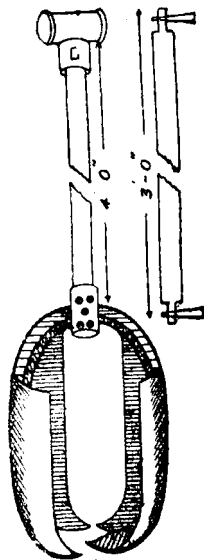

Figs. 49 and 50.  
Earth Auger and its  
parts.

The site selected for the bore should be on an elevation and if such a site is not available, one should be made artificially by filling earth and making the surface slope down on all sides, as shown in Fig. 52.

A hole of from 9 to 16 inches diameter is drilled vertically into the soil by a steel instrument called an earth auger. It consists of four fan-shaped fins about 12 inches long with a vertical rod rivetted at the top, as shown in Fig. 49. The total length of the auger is 4 feet, but by means of a junction piece, rods 3 feet in length as shown in Fig. 50 can be joined to it by means of a cotter pin and thus it can be lengthened to any extent. First a small pit, about a foot deep, is excavated by a pick-axe, and the auger held vertically in it and by inserting a wooden handle or a steel rod horizontally into the 'eye' at the top to apply leverage, it should be turned by two men going round and at the

same time exerting some pressure on the instrument. The instrument should be lifted to the ground surface from time to time and the earth core collected by the auger removed and the auger introduced again and rotated. Incidentally, this earth core serves to show the samples of the strata passed through. When about  $2\frac{1}{2}$  feet depth is reached, a 3 feet lengthening rod should be connected and further work resumed. Four able-bodied men are required for a bore-hole. While one pair is working, the other takes rest. In this way a hole 8 to 10 feet deep can be bored in one day. If the sides of the bore are likely to cave and fall in, a casing of split bamboos should be inserted.

When the bore is completed, a seat, either of wood, stone or brick masonry, or specially moulded concrete as shown in Fig. 52 with 7 inches wide hole in the centre should be fixed for squatting and a small chamber with walls of bamboo matting or coarse cloth, and a roof formed on top as shown in Fig. 52.

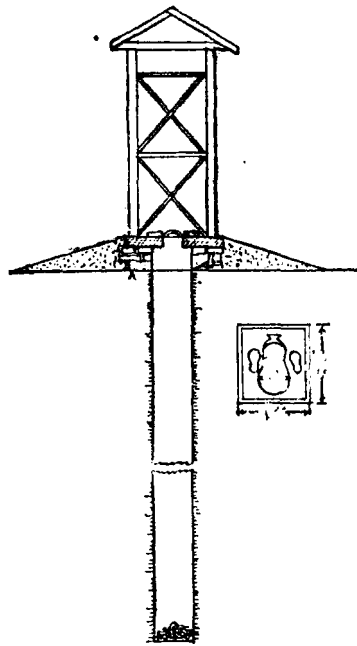

Figs. 51 and 52.  
Section of a Bore-hole latrine and  
Plan of the seat.

Bore-hole latrine does not require earth and ashes to be sprinkled on the faeces, nor is it necessary to exclude ablution water from it. In these respects it is more convenient than an earth closet.

The cost of the auger together with extension rods is about Rs. 150/-. It can be purchased on a co-operative basis. For a family of 7 or 8 souls, a bore 15 feet deep provides a capacity sufficient for one year.

When filled up to two feet below the top, it should be completely filled with earth and a heavy stone kept on its top. After 2 or 3 months, the bore-hole should be emptied by the same instrument. This time the drilling is very easy and two men can do it in one day. The cost of a bore-hole, including a rent of two rupees for the auger, amounts to Rs. 10/- and the valuable manure is easily worth Rs. 20/-.

The bore-hole is automatic in action and, if not overloaded, does not give out any foul odour. Even though the sub-soil water rises, say, up to  $\frac{1}{2}$ ths of its depth in the wet season, it gives satisfactory work. The only precaution required, if it is infested with a kind of blue flies called "Blue Bottle" flies, as sometimes happens when the bore-hole is filled up to 2 or 3 ft. below the surface, is to put about 3 lb. of fresh quicklime into the hole.

The bore-hole satisfies all the requirements of an ideal system except one, viz., it is likely to contaminate the supply from a well. It should not, therefore, be drilled within at least 50 feet from a well and further, the same bore-hole, after it is once filled and emptied, should not be used again if it be near a well, but another should be drilled away from the first.

Fig. 54.

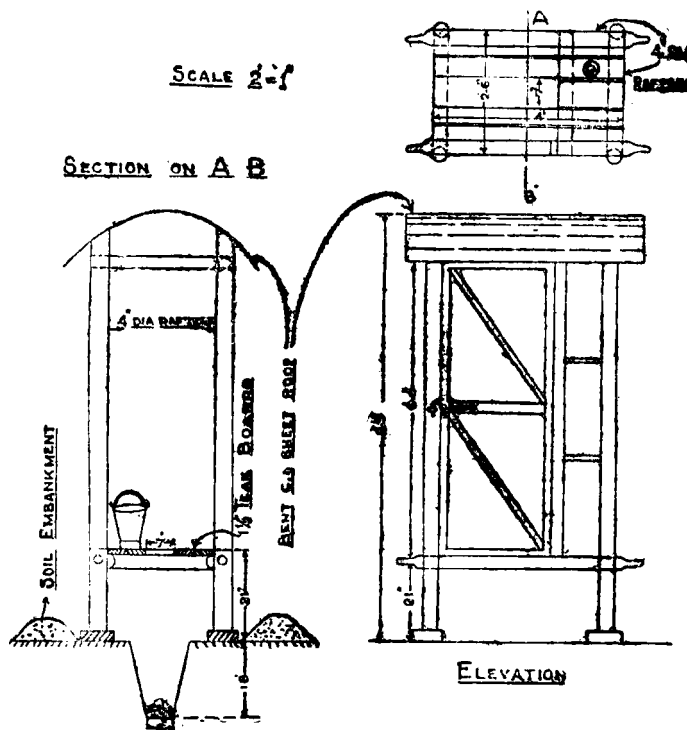

Fig. 55.

Fig. 56.

Plan and Section of a Stretcher type portable Trench Latrine.

(6) **Trench latrine** :—This works on the principle of the earth-closet and in essential particulars, does not differ from it. This is specially suited to Village Associations. For a village with a population of 500, a trench latrine of 10 seats is sufficient. The latrine should be arranged in two rows, one for men and the other for women. A trench, not more than 4 feet deep and 3 feet wide at top and of length at the rate 2 feet 9 inches per seat, should be excavated just outside the village away from the direction of the prevailing wind and either dry earth should be provided in kerosene oil empty tins open at top in each latrine for being spread by each user, or a special man should be appointed to do this.

An improvement over this can be made by building brick-lined trenches and placing either portable or folding latrines on their top. There should be

two sets so that while one is being used, the other, which is already filled, is given some rest for the contents being converted into harmless manure. Use of clean waste papers should be encouraged by supplying them, instead of water, for ablution which requires more earth and makes the problem difficult.

For domestic use, a portable trench latrine is very convenient. Figs. 54 to 59 show a cheap design which the writer suggested

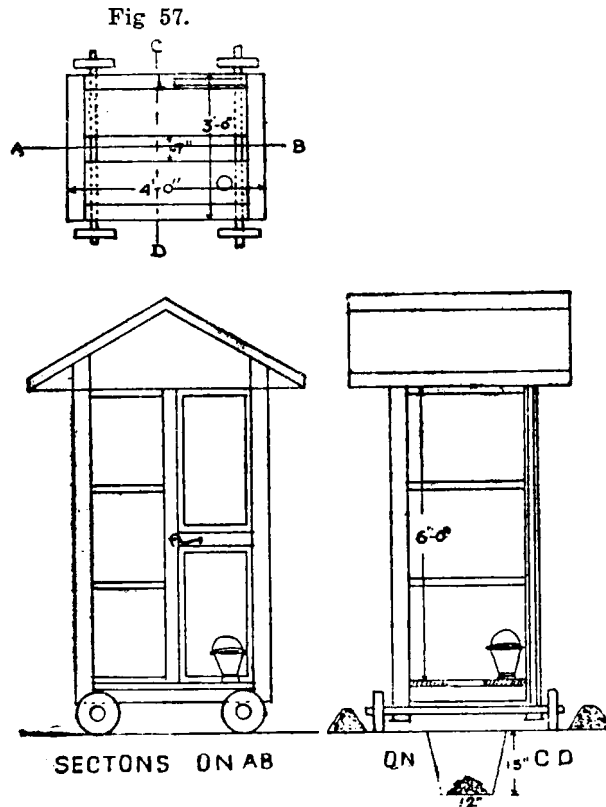

Fig. 58.  
Plan and Section of a Truck type portable Trench Latrine on wheels.

Fig. 59.

be provided preferably with a self-closing spring. A suitable roof may be provided on the top.

This portable latrine should be placed centrally above a trench 6 inches wide at bottom and sloping sides, and with the top 18 to 24 inches wide and of the same depth. The earth excavated from the trench should be heaped in long ridges on both sides to exclude surface flow of rain water from the trench.

A bucket, full of ashes and dry earth mixed together with an iron scoop in it, should be kept inside the latrine. The user of the latrine should spread the mixture with the scoop on the faces so as to completely cover them.

to 59 show a cheap design which the writer suggested a few years ago and has since been adopted by several Village Uplift Associations and a large number of them have since been giving perfect satisfaction. The squatting platform (Fig. 54) consists of a frame, made like that of an ambulance stretcher but only half as long, with projecting handles of a frame of two 4 feet and two 2½ feet long pieces of wood. Upon these are nailed 1½ inches boards so as to leave a lengthwise gap 7 inches wide and 2 feet long in the centre. The platform should then be fixed between four vertical posts about 8 feet long, at 2 feet from the bottom. The frame thus formed, should be enclosed either by bamboo matting or hesian cloth nailed on to it and on one side, a door should

When the portion below the trench is nearly filled up to the ground surface, the portable latrine should be lifted by means of the handles and placed a few inches forward or backward and some earth from the side ridges drawn to fill the portion previously used.

A trench 10 feet long would last for over 8 months for a family of six souls.

Instead of a stretcher-like frame with posts resting on the ground, if four wooden wheels with axles, are fitted as shown in Fig. 57, it would be easy to push the portable cart latrine without much effort. A complete latrine, which cost Rs. 11/- in 1935 is shown in the photograph in Fig. 60.



Fig. 60.  
Photographic view of a Stretcher type  
Trench.

to prevent flies sitting. If trouble from Blue Bottle flies is experienced, quicklime should be spread on top of the trench.

*Advantages :-*

- (1) If the above precautions are taken and earth is regularly spread, the system is most satisfactory.

*Precautions :-*

- (1) Choose a site, the wind from which will not blow towards the home to preclude the possibility of a nuisance, should anything go wrong at all.
- (2) The site should be as far away from a well as possible. As a further precaution, if a well is close by, the trench should not be more than a foot deep and more earth should be used, so that the sewage will not concentrate at one place and the chances of contamination of water would be reduced to a minimum.
- (3) Proper precautions should be taken that rain-water will not enter the trench, at least will not form a pond on its top.
- (4) Once a week, crude oil should be sprayed by means of a 'Flit' or 'Poysha' pump over the trench and floor of the latrine

- (2) It affords the best privacy. Even the *purdah* ladies, children and sick people would find it convenient.
- (3) It is very cheap both in the first instance and also in maintenance.
- (4) The construction is very simple ; materials required for its upkeep, *viz.*, dry earth, ashes and crude oil are all handy. One gallon of crude oil costs nine annas and will last for a year. There is nothing likely to go wrong.
- (5) The capacity of an earth-closet is limited ; that of this trench is unlimited, since the bed and sides are all absorbent and so, less earth is required than in an earth-closet. There is no necessity of doing ablution in a separate sink.
- (6) As the latrine is moved from place to place, the concentration of sewage is prevented and thus there is very little chance of contamination of well-water. The excreta are converted into harmless humus within 8 days.
- (7) It is not necessary to empty the trench as in the case of the earth-closet or the bore-hole, and still, the benefit of the valuable manure is fully derived, since, whatever crops or vegetables are grown on or near the trench, their roots will obtain the nourishment.

(7) **Septic Tank** :—There are two wrong notions, which are opposed to each other, prevalent among people about the septic tank. There are some people who believe that a septic tank is a very complicated affair and that it requires a large quantity of water for purification and if that is not available, it is bound to be a failure. The other people, who are enthusiastic advocates, maintain that they have found a very cheap and easy method of disposing of sewage which is infallible. Both are partially wrong. Septic tank action is a very simple natural process and there is nothing complicated in it. Domestic sewage in particular is very simple and easy to treat as compared with sewage from a city which contains trade wastes, acids, grease and many other things difficult to digest, and can be easily purified by the installation of a septic tank. However, it costs a minimum of Rs. 150/- exclusive of the cost of the latrine and does require some water for proper working. However, if it is suitably designed, it can function very satisfactorily even with a supply of one gallon per head per day. The supply can be supplemented if the waste from a bathroom is led to the septic tank.

What is a septic tank? It is a cistern, either of masonry or concrete, built mostly underground, filled with water and provided with a cover. The sewage, including the solid excreta, is allowed to enter it at one end and after undergoing certain chemical changes during the period it remains inside the tank, is allowed to escape from the opposite end.

**The Action of Septic Tank :** The word 'septic' is derived from *sepio* 'to rot' and the primary function of a septic tank is to allow the sewage to rot or putrefy. Now, when a substance rots—take for instance, a mango, either raw or ripe—it first becomes soft, and as time passes on, becomes still softer and softer, and if it be opened at this stage, the liquid stuff comes out, which also rots, in course of time, and is reduced in quantity by the formation of gases which escape, giving out bad odour, until finally, a very small quantity of solid matter, mostly the rind and stone, remains out of the large and fairly heavy mango in the beginning. Exactly the same thing happens of the solid contents of sewage, inside a septic tank, which, on account of the very favourable artificial conditions inside it, hastens the process.

This process of rotting or putrefying is caused by the growth of a sort of very minute germs, or bacteria, which very rapidly multiply and feed on the organic matter. These bacteria abhor air, the oxygen in which kills them. Hence, they are called "Anærobic" bacteria. Darkness, humidity and warmth, which are all present in a septic tank, help their growth.

The septic tank does one more function besides that of *liquefaction* mentioned above. It is *precipitation* or *sedimentation*. The solid contents of sewage are composed of about 65% of mineral matter and 35% of organic matter. The mineral matter not only consists of sand, dust, ashes, etc., which find their way to the drain leading to a septic tank, but various salts such as chlorides, sulphates, carbonates, phosphates, etc., which are consumed with food and which after undergoing a number of chemical changes inside our body, pass out. The anærobic bacteria have no action on these and so they remain in the sewage intact. The heavier particles of mineral matter sink down or precipitate to the bottom of the septic tank and the lighter ones float and ultimately pass out of the tank. Out of the 35% of the solid organic matter, the heavier particles temporarily sink to the bottom and lighter ones accumulate at the top in the form of "scum." It is on these particles of organic matter that anærobes feed and breed. Thus this function of precipitation is also very important.

The bacteria live both in the scum of organic matter floating at top and also in the particles of heavier organic matter precipitated at the bottom.

They act upon and disintegrate it. The chemical action involved is very complicated, but the result is that complex compounds such as proteins, carbohydrates, fats, etc. are chemically split up into simpler elements such as carbon, hydrogen, oxygen and nitrogen. The process of splitting up is called "hydrolysis" or "denitrification" in chemistry and liquefaction or putrefaction in common language. These simpler forms are either gases or liquid acids; the gases pass off through the ventilation and the liquids through the effluent,

H-8

and thus, just as in the example of a mango discussed above, the bulk of the organic matter in the sewage which otherwise would have formed large heaps, giving out offensive smell, is reduced by about 70 to 80 % in volume in the septic tank through the agency of the anærobic bacteria.

The heavier particles of both the mineral as well as organic matter precipitate to the bottom. The mineral matter, on which the bacteria have no effect, accumulates and is known as the "sludge." There is organic matter also in the sludge, but the bacteria soon split it up into liquid and gases and continually reduce it. The sludge goes on accumulating year after year and progressively reduces the useful capacity of the septic tank, until a time comes when the incoming sewage does not get sufficient time, on account of the reduced capacity to be properly digested by the anærobic bacteria and passes out in a raw state giving out foul odour. The time has then arrived of once emptying the tank. In the case of a scientifically built domestic septic tank, this might occur once in 10 to 12 years and the inconvenience caused is just for one day. The sludge is a dark liquid and gives no more offensive smell than waste water from kitchen or bathroom flowing into open gutters. The tank can be emptied either by buckets or a small hand pump in a few hours. It may then be washed and filled with water and re-used from the next day.

It has been stated above that the quantity of organic matter present in the raw sewage is reduced by nearly 70 to 80% in the septic tank. This means that there is 20 to 30% of it still remaining in the effluent which passes out of the tank. Besides, it contains a vast number of anærobic bacteria floating on the surface and also a number of gases dissolved in it which are formed in the process of denitrification of the sewage. The latter are unstable. All these, if the effluent be left alone, would not only give out foul odour but also prove positively harmful to health by contaminating food and water supply. The effluent must, therefore, be suitably treated and this treatment consists of bringing it into contact with fresh air, the oxygen in which combines with the unstable gases and converts them into harmless compounds like nitrates, carbonic acid gas, water, etc. This process of oxidation takes place through the agency of another set of bacteria, which live where there is free supply of air and are, therefore, called "Ærobic" bacteria.

There are a number of methods of utilizing the services of these bacteria to purify the effluent, but for treating domestic sewage the easiest and simplest ones are :—

- (1) Surface Irrigation.
- (2) Soak Pit.

Both these, particularly the soak pit, require very little attention.

For surface irrigation, the soil must be of a porous nature, in the innumerable pores or voids of which, myriads of ærobic bacteria live and do

their work silently. Light, sandy soil is the best. The soil which is most suited for plant growth is good also for this purpose.

If a piece of ground with such a soil is available on the back side of the house, the effluent may be led to it through a half-round stoneware pipe drain and allowed to spread in furrows of loose soil, and vegetables may be grown on the top of ridges. As far as possible, leafy vegetables, which are eaten raw, should not be grown. Two plots should be made side by side and the effluent diverted to each alternately. The soil surface should be mulched or loosened from time to time. In America excellent lawns are also grown.

For the second method also, viz., soak pit, the sub-soil, which is capable of absorbing or draining water is the best. A pit of a size depending upon the porous nature of the sub-soil should be excavated, say about 4 feet deep and filled with stone-rubble having rough surface, overburnt bricks, lumps of furnace or boiler slag, etc., very loosely in a layer of about 1 foot 6 inches to 2 feet ; above it should be spread a layer of gravel or unscreened sand and the top 9 inches to 1 foot should be filled with loose porous soil. The effluent should be led so as to flow on the top of the gravel or sand. Care should be taken to cover the drain. The voids in the loose material contain air and so aerobic bacteria make their abode on the rough surface of stones or bricks, or in the voids of gravel and do their work efficiently. If, instead of a pit, a trench is excavated, it should be about 18 inches wide at bottom 4 feet deep with sloping sides and 2 feet to 3 feet wide at top. If it be *murum*, laterite, sand, or such other very porous sub-soil, even 10 feet to 15 feet length will suffice. At the other extremity, a 50 feet length may be required in sticky clay material.

Surface irrigation does require some attention for diverting the flow to alternate plots and also for loosening the soil. But the soak pit is an automatic and fool-proof arrangement.

The writer has built a large number of such domestic septic tanks with soak pits with excellent results without a single failure.

From the foregoing discussion of the principles of a septic tank it will be seen that a good design should incorporate the following features :—

- (1) The contents should remain as quiet as possible, i.e. there should be no disturbance or churning action caused, as the latter will dislodge the anærobic bacteria both from the scum and the sludge. This can be accomplished by (a) making the tank deep ; (b) arranging the openings of the inlet and outlet pipe about mid-way ; and (c) providing one or more baffle walls or scum boards to damp waves caused by disturbance.

- (2) The incoming sewage should remain as long as is conveniently possible, inside the septic tank. This could be arranged by (a) making the tank long and narrow so as to increase the length of travel ; (b) providing a larger capacity consistent with economy.
- (3) The whole arrangement should be air and water-tight. To attain this (a) the bed should be of at least 6 inches of concrete and sides of 9 inches brick-in-line masonry and both should be plastered smooth with cement. (b) There should be an air-tight cover—either of brick-jack-arches or R.C.C. slabs with an opening for inspection closed with cast iron cover at the top. (c) A ventilating pipe of at least two inch diameter should be provided and carried to such a height as would not cause any nuisance.

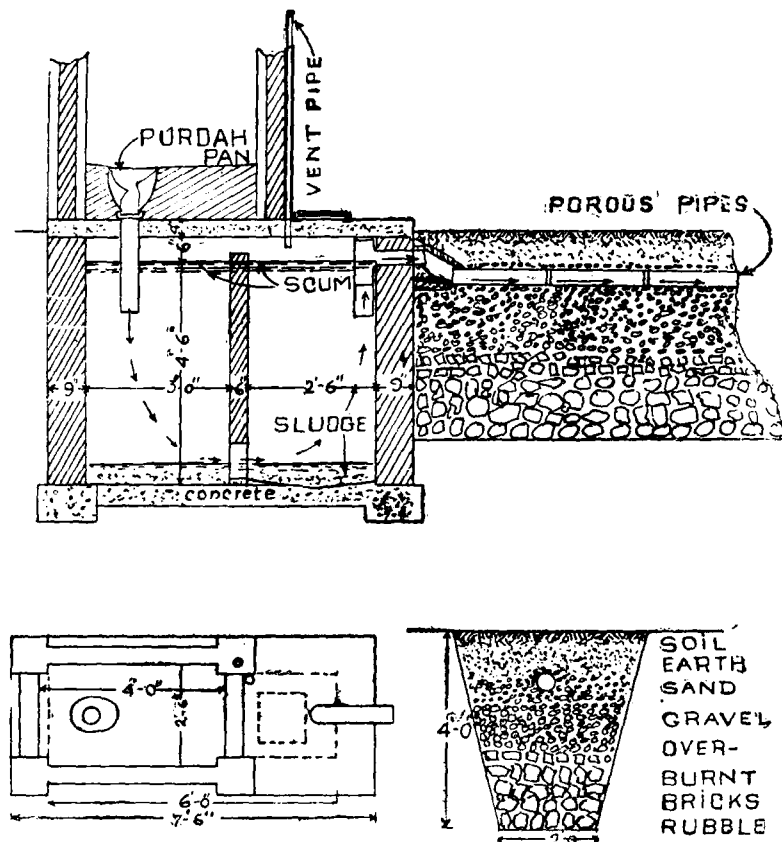

Figs. 61, 62 and 63—Plan and Sections.  
Design of a cheap Septic Tank.

Three separate designs of septic tanks, each suitable for a family, of members upto 12 in number, are given below :

**Design No. 1\*** : This is the most economical design, and as it requires a very little quantity of water to maintain it, it would be very suitable for areas where there is scarcity of water. In fact the water normally used for ablution, plus a bucketful poured every night for flushing and cleaning the floor and pan should suffice. It is, however, advisable to take advantage of the water from a bathroom, after straining it through a suitable grating to exclude mineral matters such as sand, ashes, etc., and utilise it in the septic tank to dilute the sewage. For this the bath must be at a higher level than the septic tank.

The septic tank (See Figs. 61-63) occupies an area of 7 feet 6 inches  $\times$  4 feet, including 9 inches brick walls on all sides, so that its inner capacity is 6 feet  $\times$  2 feet 6 inches. It has a reinforced concrete cover 4 inches thick. The latrine is erected just on the top of a part of the septic tank. This has resulted in economy of foundations and one wall, drain and a trap below the pan. The pan is of a special kind called "Purdah Pan". It is white glazed on the inside and has two steep slopes on opposite sides as shown in Fig. 61 which cause the excreta to slide down with a very small quantity of water for flushing. Fig. 64 shows an enlarged view of the pan. A 4 inches

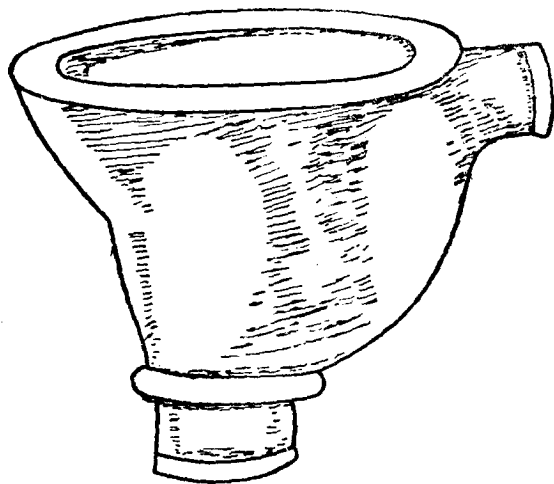

Fig. 64—Purdah pan.

diameter stoneware pipe 2 feet long is joined vertically below the pan and as it dips about 12 inches in the water it provides a very good water seal. This dispenses with the necessity of a trap which is normally required. The outlet pipe consists of a 4 inches diameter stoneware T-junction pipe with its longer leg dipping completely into the water. The horizontal portion of the T-pipe is placed at 4 feet 6 inches above the bottom so that there is a 6 inches air space above water

surface. A ventilating pipe is inserted to project about three inches below the under-surface of the R.C.C. cover. A 6-in. partition of bricks in cement mortar is provided with a number of holes in a horizontal layer at 6 inches and

---

\* With acknowledgment to Ushagram School Colony, Ushagram, Asansol, (Bengal) from whose design the main idea is taken.

2 feet 6 inches above the bed. This wall is necessary to check the disturbance caused by the solid excreta dropping down vertically. A cast iron cover is is

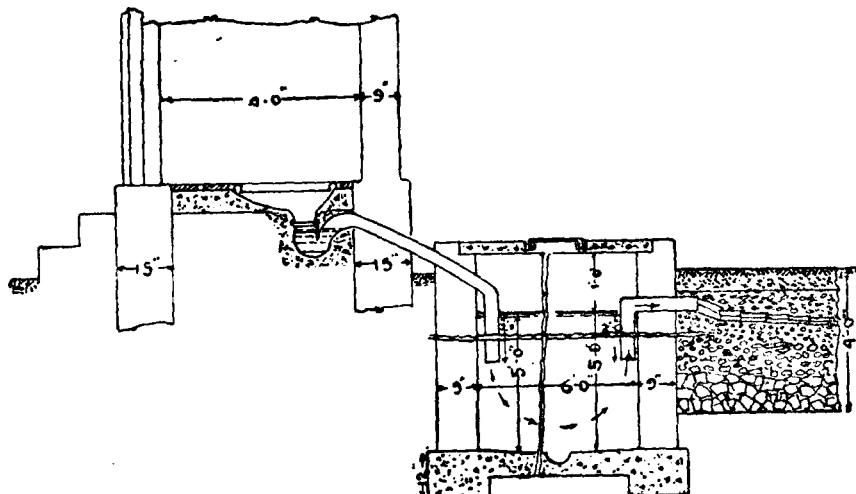

Fig. 65.

A Design. for converting an existing latrine on Basket system into one suitable for a Septic tank.

provided on the top of the second chamber for facilities of inspection and emptying the tank when filled with sludge.

The effluent is led through ordinary baked porous clay pipes with the smaller end simply inserted into the larger one and these rest on the top of a trench 2 feet wide at bottom,  $3\frac{1}{2}$  feet at top and 4 feet deep (see Fig. 63) filled with materials shown in the section. The total cost of this installation, including the walls and roof of the latrine, is about Rs. 100/-.

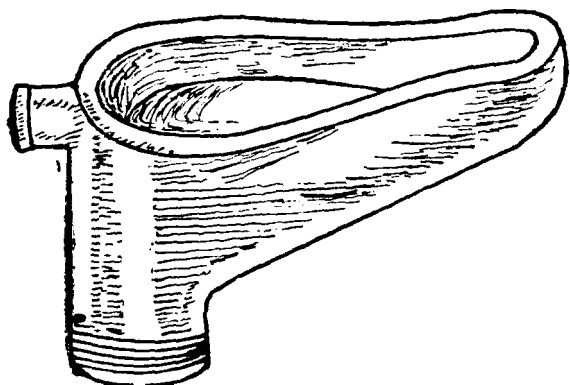
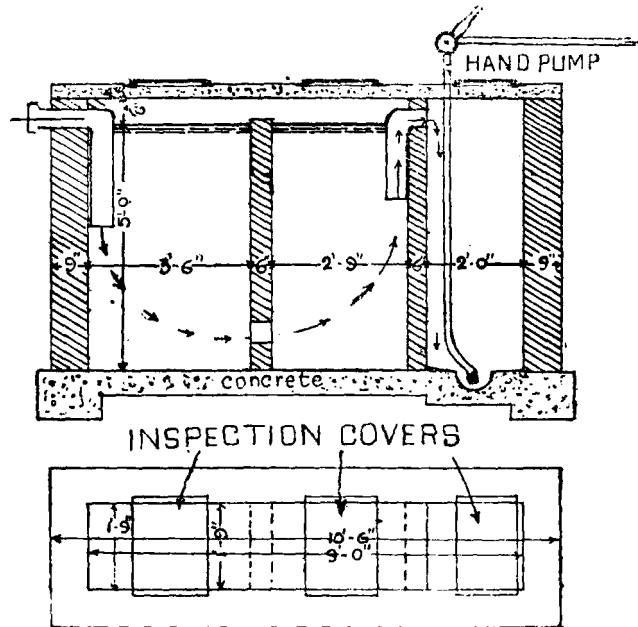

Fig. 66.—Indian Pattern W. C. Pan.

Design No. 2 : This is a design suitable for an existing latrine which is built for the hand removal system, but is to be converted into one suitable for a septic tank. (See Fig. 65). The space below the seat formerly occupied by the basket is filled with rubble or brick-bats and a W.C. pan of the ordinary type with trap is fitted at top in concrete. Fig. 66 shows an enlarged view

of the pan. A pipe connected to the trap is extended so as to dip about 2 feet below the surface of water in the septic tank built close to the latrine. The



Figs. 67 and 68—Section and Plan of Design No. 3 of Septic Tank.

septic tank is 6 feet long, 1 foot 9 inches wide and 5 feet deep inside the walls. There is no necessity of a partition as in Design No. 1. The outlet pipe should start from 2 feet below the surface of water and should have either a T-junction pipe or an elbow joined to it at the top. The soak pit or soak trench should be similar to that for Design No. 1. A pit or a depression about three inches deep should be made in the centre and a fall to the surface at bottom should be given towards it in the bed of the septic tank. An opening about 12 inches by 18 inches should be left in the cover at the top and closed by a cast iron manhole cover. It is desirable to provide a ventilating pipe, of at least 2 in. diameter.

**Design No. 3:** This is rather expensive. The whole house is provided with suitable drains with the drain from the bathroom at the top of the whole system, so that all the waste water from kitchen, bathroom, and all other sinks is collected and led into the drain carrying sewage and finally admitted into the septic tank, which may be built on the back side of the bungalow away in a corner. The septic tank consists of two chambers, 3 feet 6 inches and 2 feet 9 inches long respectively, 1 foot 9 inches wide and 5 feet 6 inches deep as shown in Fig. 67. The openings in the partition are left at two levels, *viz.*, at one foot and 3 feet above the bottom. There is a third chamber 2 feet long

in which the outlet pipe from the septic tank discharges the effluent. A sump is formed in the bottom of the latter in which the foot valve of a one inch hand pump rests. The delivery pipe of the pump is connected to a perforated pipe laid on the surface of ground where a hedge is grown. At a certain fixed hour

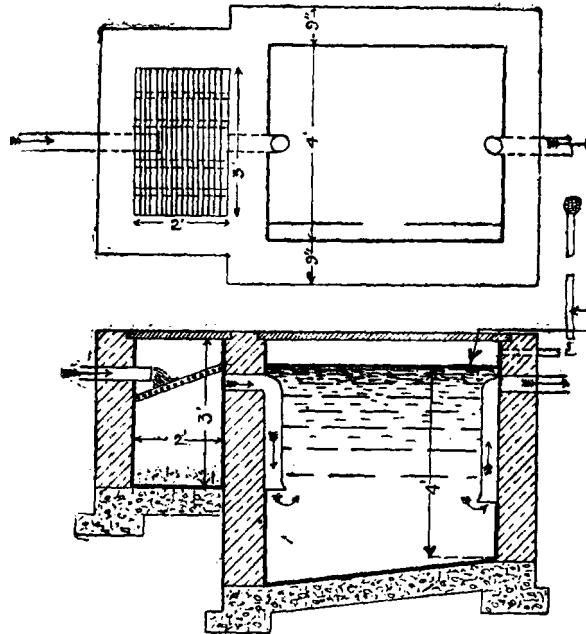

Figs. 69 and 70.

The Grit Chamber is shown on the left hand side with the Grating in Plan and Section.

of the day the pump is worked for a few minutes and effluent is forced through the perforations, so that it falls in fine spray near the roots of the hedge and being exposed to air is partially oxidised. It is further absorbed by the soil and assimilated by the roots of the hedge.

All the three chambers are provided with cast iron inspection covers.

When the entire drainage from a house is collected together for being treated in a septic tank, it is quite necessary to provide one more chamber called *grit chamber* 2 feet long, 1 foot 9 inches wide, and 3 feet deep with a grating of iron rods as shown in Figs. 69 and 70 which is an old design of a septic tank. This chamber serves three purposes: first, that all the silt such as ashes, earth, brick-dust, etc., used for burnishing utensils falls through the grating and collects at the bottom of the grit chamber. This would otherwise have entered the septic tank; the second, that shreds of paper, rags, loose coir, etc. used for burnishing utensils, which do not easily rot are arrested by the grating and excluded from the septic tank, and the third, that the solid excreta are also

arrested by the grating and broken up by the jet of sewage which falls on their top and thus the work of the septic tank is simplified.

The following table gives the minimum inside sizes of septic tanks suitable for domestic purposes :—

Members of family including servants	Length	Width	Depth of Water	Cubic Contents	Allowance per head
10	5'-6"	1'-6"	4'-6"	36.2	3.62
15	6'-0"	1'-6"	5'-6"	49.5	3.33
20	6'-0"	1'-9"	5'-6"	57.25	2.88
30	7'-6"	1'-9"	6'-0"	78.00	2.60

#### Upkeep of Septic Tank Installation

(1) If there is scarcity of water and therefore Design No. 1 is adopted, the bucketful of water used once at night for flushing and cleaning should not be poured all at once, but the floor and pan should be first cleaned with a brush and a little water and the bucket poured slowly to wash away the dirt. This precaution is necessary for preventing a churning action inside the tank.

(2) In the case of Design No. 1 it is possible that the solid excreta might accumulate at times in the vertical pipe and choke it, causing bad smell also. The obstruction should be removed by pushing it down with a rod.

(3) As far as possible strong disinfectants or acids should not be used for cleaning sanitary wares and flushing drains. These kill the germs. However, if white glazed surfaces are stained yellow, a rag dipped in weak Muriatic acid may be rubbed against it occasionally.

(4) It is the custom in some houses to allow young children to answer the call of nature on a piece of paper and to throw the paper with contents into a W. C. pan. This is a very bad practice particularly when the sewage is treated in a septic tank. Paper and rags take a very long time to rot; besides, they are likely to choke drains.

(5) If a ventilating pipe is not fixed on the top of a septic tank it is possible that inflammable gases like the marsh gas ( $\text{CH}_4$ ) might accumulate in the empty space below the cover. Hence, when the manhole cover is opened, a lighted cigarette or a candle should not be brought near it, which might cause an explosion. It is always safe to provide a ventilating pipe to leave no chance of a risk.

(6) If only the water from latrines be admitted into the septic tank, and no extra quantity is used for flushing, it is possible that the losses by eva-

poration might exceed the incoming quantity of liquids. This might cause the level to sink, causing foul odour; to remedy this one or two buckets of water may be poured into the latrine, occasionally.

The same thing might happen if the latrine remains unused for some length of time. In such circumstances a bucketful of water should be poured once a week into it.

### Disposal of Urine

We now come to the question of the disposal of human urine. The usual practice of committing nuisance indiscriminately in the premises of the house is to be strongly condemned. It is forbidden by sanitary law even to abuse a street corner in this way, and one who misuses such places is liable to be prosecuted before a magistrate. Some people make use of sinks in the bathroom for the purpose. Though this is better from the point of view of privacy, it is also objectionable unless there is a flushing system with underground drains, or copious water is used by hand on every occasion for flushing, and further, the water is treated suitably. The best way is to build a small urinal in a corner of the compound outside the house with an earthenware half round channel at least 6 feet long to carry the urine diluted by a flush of water into an underground soak-pit consisting of a trench about 2 feet deep filled with rubble at bottom and graded gravel and sand above. The coarser material should be laid at bottom and finer at top.

Another way is to keep a china or enamelled pot with a large mouth and a close cover with some saw-dust in it. Each time use is made, some ashes should be sprinkled on the saw-dust. At the end of the day the pot should be emptied in the manure pit, washed and kept for use again. Saw-dust holds its own volume of urine and prevents any possibility of its being spilt, and ashes check putrefaction and have also a deodorising effect.

### Disposal of Horse and Cow-dung

Then comes the question of the disposal of other excremental matter viz. that of domestic animals such as cows, horses, etc. The question of collection and disposal of it in rural districts and in dairies, stables of horses kept for public use, etc. where the dung of a large number of animals has to be dealt with, requires special consideration which is outside the scope of this book. It is only of an animal or two which are usually kept by middle class men, that is proposed to be discussed here.

The usual practice, is, in municipal areas, to throw the waste fodder and litter into the municipal dust-bin and utilise the cow-dung for preparing dung cakes to be burnt as fuel. In small towns and villages where there are no municipalities, the former is thrown into a muck heap close to the house and the latter used for the same purpose viz. preparing cow-dung cakes for

fuel. The latter is a very bad practice both from the economical and sanitary point of view; because, its value as a manure is several times greater than that as a fuel. Again, considerable time is wasted on the preparation and drying of cow-dung cakes, which can be better utilised for more important work. When agriculture is starving for want of manure and is yielding a very poor or no crop, it is a pity that we should burn cow-dung which is an excellent manure. Everyone, no matter whether he is an agriculturist or not, must regard the burning of cow-dung cakes for fuel as a national waste and a sin against agriculture.

One way of treating dung of domestic animals is to store it in a pit in the compound as far away from the house as possible, situated in such a place that the wind will not blow from it towards the house. The ideal conditions are that instead of an underground pit a masonry chamber lined with cement on the inside should be constructed above the ground with a roof over it. The door for throwing the dung into the chamber should be self-closing. There should be another door for removing the manure and a ventilating pipe carried high above the ridge for letting out foul gases; but the middle class people of India cannot afford this. Hence, we must be content with a pit excavated in a distant corner.

The danger in this arrangement consists of contamination of the water supply of wells, if situated at hand, by the sewage percolating through such pits. When such a manure pit is started, the unpolluted soil surrounding it is able to filter the liquid portion, which thus reaches the water-bearing stratum in a fairly pure condition, but as the strata forming the filtering media become polluted by soakage of the sewage, they lose their power of filtration and the liquid sewage passes unfiltered to a lower and lower level until it ultimately reaches the water-bearing stratum from which the wells derive their water supply.

To guard against this danger, the following precautions must be taken :—

(1) No liquids should be thrown into the pit. Every possible precaution should be taken to divert rain-water flowing towards the pit. In other words, the contents of the pit must be kept as dry as possible.

(2) The pits should not be very deep; but this is possible only if the space is ample.

(3) The pits should be lined on the sides and bottom with brick or stone masonry and plastered with cement if the sub-strata are very pervious.

(4) Ashes, dry earth, and similar deodorising agents should be occasionally spread in sufficient quantities in the pit.

(5) The pit should be emptied at short intervals and the manure utilised for agricultural purposes.

(6) Some sort of roof, though not absolutely water-proof—say even of thatch—should be erected to prevent rain from falling into the pit.

To keep off flies feeding and breeding on the heap in the pit, it should be covered with waste fodder from the shed or stable on which should be sprinkled crude oil from time to time.

**Composting** :—Recent experiments and research conducted both in this country and elsewhere on a large scale have proved that the best method of treating all sorts of organic matter, not only dung of cattle but also human excreta, together with vegetable refuse matter such as waste fodder, garbage, grain husk etc. is to convert it into compost. This is especially very suitable for tropical countries like ours. By this means not only all organic matter is rendered harmless, but it is utilised in producing very valuable manure providing necessary nitrogen and phosphorus.

Composting is a very convenient method of disposing of cattle dung both on a small and large scale. For treating the dung of one or two animals excavate a pit 2' × 2' × 2' to 2½' deep at least 30 feet away from a well in a corner of the compound at such a place that the wind from it will not normally blow in the direction of the house. The earth dug out should be stacked in heaps on all the four sides. A layer of refuse such as waste fodder about 3 in. thick should be spread at the bottom, and on its top one of dung thinned with water so that it will easily flow from a bucket should be evenly spread on it in a layer not exceeding 2 in. in thickness. On the top of this another layer of vegetable refuse, or if this is not available, dry earth from the heap should be spread in a layer of about two inches so as to cover it completely. In this way alternate layers of dung and refuse or in the absence of the latter, dry earth should be put every day till the pit is filled. It should then be covered with a six in. layer of dry earth, and left to itself. In the course of about a month in summer and two months in other seasons, the entire contents of the pit will be converted into humus ready for use in the field or garden.

What takes place inside is that decomposition starts just in 2 or 3 days, which gathers strength progressively by the development of micro-organisms accompanied by considerable heat which may often exceed 150°F. The heat is the measure of the microbial activity. It destroys all pathogenic organisms and also prevents breeding of flies as it kills the maggots. When the first pit is filled another should be excavated nearby. The only precautions required are: (1) to keep the dung completely covered under earth, (2) to prevent rain water from surrounding ground from flowing into the pit. (3) If there is a wall within 30 ft., the pits should be shallow, say 1 to 1½ ft. deep. The same pit may be used again after it is emptied and exposed to sun for a month.

#### Disposal of Slop Water

The next thing to be considered is the disposal of the waste water which goes under the general name of sullage water as distinguished from sewage. It consists of slop water from the kitchen, sink and waste water from the

bathroom. The present practice, in municipal areas where there is no water-carriage system, to allow it into the open street gutters, is very pernicious. The channel leading thereto, from the sinks is often not well graded, nor constructed of water-proof material, in consequence of which the water generally soaks into the ground close to the house, causing damp to rise and mosquitoes to breed. Even if it finds its way to street gutters, the latter are generally choked with debris, which obstructs it and the same result follows, if only a little further away from the house.

In non-municipal areas no attempt is made to lead the water away from the house at all and, in consequence, it soaks into the foundation of the wall and the floors of the house, causing bad smell and damp to rise and mosquitoes to breed.

The proper way of disposing of the sullage water is given below :

At the outset it must be remembered that water from latrines, which contains pure sewage of a dangerous character, must in no event be allowed to enter the drain meant for sullage water. The sewage requires quite a different treatment which has already been described in a previous chapter. The slop water from kitchen sinks and the waste water from the bathrooms, the composition of which is different, require slightly different treatments in the earlier course ; because the slop water from the kitchen contains some oils and fats, cream rising at top in the *congee* (gruel) while boiling the rice, peels of onions and vegetables, etc., which must be first separated. Otherwise, they are not only liable to choke the drains, but the fats in them render the problem of disposal of the water more difficult. The waste water from Indian bathrooms is, in most cases, likely to contain urine. Hence, it is safe to take some precautions to prevent foul gases from entering the house.

A sink in the kitchen need not be larger than 2 feet by 2 feet. If it is to be used only as a kitchen sink, i.e. not for occasional bathing, even 18 inches by 18 inches will suffice. The flooring should be of a flagstone in one piece with a slope towards a corner and not towards any side. A piece of pipe at least 2 inches in diameter should be laid for leading the water to the outside. The pipe, which should not be provided with an elbow, should drop the water on to the top of grass put into an iron bucket or half-cut kerosene oil tin with perforations at the bottom. Thus all the solids, including fats, will be arrested by the grass allowing only the slop water to trickle down. There should be another small chamber, lined with cement on the inside, just 6 inches deep below the perforated tin for collecting water and allowing it to run through a drain of half round 4 inches earthenware pipes starting from it. The drain should be open throughout and as long as the space will permit. The water should finally be led to the roots of vegetable or flower plants by turn.

In the absence of any flower or vegetable garden, the water should be collected in a cement lined masonry cistern, from which it should be daily

taken out by hand-bucket and sprinkled over open ground for being purified by the actions of the soil and the sun's rays.

If the surface of the ground be limited in extent, some sort of vegetation—even grass may be grown on it. Roots of living vegetation very quickly absorb and assimilate the impurities and render them harmless. The same treatment is required for waste water from bathrooms except that a *nhani* trap

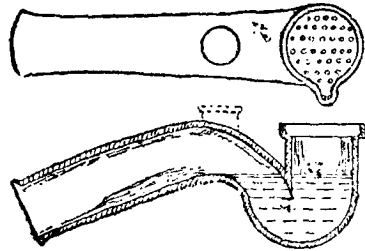

Fig. 71 & 72.

illustrated in Figs. 71 and 72 should be fixed in a corner of the sink, towards which the floor should slope. This trap has a water seal which prevents foul gases from the drain rushing back into the bathroom.

The object of the long open drain for carrying slop water is that by exposure to the air, sun-heat, cold and drying winds, the putrefaction is checked and the production of foul gases is rendered impossible.

Sub-soil irrigation and pit filtration are other remedies for the purification of the slop water, but are not recommended in consideration of the habits of the Indian people. For, unless carried out on strict sanitary principles, they are very likely to prove a greater evil by becoming the breeding grounds of mosquito-larvæ.

#### Disposal of Dry Refuse

We next come to the question of removal and disposal of dry refuse such as sweepings from the house, rags, pieces of paper, peels of fruit, leavings of food, plantain or other leaves used as plates for dinner, etc., etc.

For perfect success in this respect a radical change in our habits must be effected. Even the young children must be trained not to throw about carelessly pieces of paper, peels and stones of fruits, shells of ground-nuts, chewing of sugarcane, etc., not only inside the house but also outside. They should be trained systematically to put them into small receptacles provided with lids and placed in a corner of every important room. Even grown-up people are in the habit of throwing, through windows or door openings, that sort of litter into the compound, and the idea scarcely enters their minds that they are doing even a greater harm than by throwing it inside the house. For, if the litter be scattered inside the rooms of the houses, it gets a chance of being swept once or twice a day, but if such waste things are thrown into the compound they decompose, vitiate the air surrounding the house with foul gases, which are inhaled by the inmates. Such rubbish attracts flies, which transfer disease germs from its surface to the articles of food. For this purpose, the premises of the house must be kept as scrupulously clean as the inner apartments. It would be a great advance upon the existing state of

things if the plan were universally adopted, and every one in the household would do his or her bit, not necessarily in cleaning, but in preventing dirt by acquiring cleanly habits.

The receptacles in which dry refuse is collected should be emptied at least once a day into dustbins in municipal areas, and where municipalities do not exist they should be treated as described later on.

The public dustbin in India is an abominable nuisance. It is never used properly, for fear of the user, particularly of the Brahmin Community, being defiled, if one happens to touch it. The contents of the receptacles are thrown in from a distance with the result that hardly half the *kutchera* falls into the bin while the remaining half falls outside it. The next person, especially if she be a female, is afraid of touching the rubbish scattered outside by the previous person for the same religious prejudices as above and empties her basket from a still longer distance. Ultimately the middle of the street is reached by the heap of the refuse meant for the dustbin, leaving the latter practically empty. Such a scene affords a suitable place for the young children of the adjoining house to commit nuisance. If a dinner or a feast is given in any of the houses in the street on account of the celebration of a marriage or of like festive occasions, the plantain or other leaves used as plates for dinner are thrown near the dustbin with remnants of food sticking to them. Stray dogs, cows, pigs, cats, and fowls stir up and scatter the rubbish with a view to feeding on it; wind helps further and thus the entire street often presents an appearance of a muck-heap until the weary and indifferent municipal sweeper comes with a bullock-cart to collect and remove it haphazardly with no special mission, to confer the boon of sanitation upon the locality.

In moffusil areas, where there are no municipal organisations, it is advisable to sort out the rubbish coming from the homesteads. The portion which is capable of rotting should be put into the manure pit and covered with ashes or dry earth, and that which is capable of drying easily should be burnt in a pit and the ashes, so obtained, used for covering the manure pits or trench latrines. Those who can afford to spend more should build simple types of incinerators which burn such rubbish efficiently in a short time without producing volumes of smoke.

---

## Domestic Water Supply : XIV

Next in order of importance to air, water is another prime necessity of life. Life cannot be sustained even for a few minutes without air ; without water, it can be sustained for a longer period ; still, death is sure to ensue.

Water, from whatever source it may come, e.g. a river, a lake, a spring or a well, is all originally derived from the rain. The water as it comes from rain is distilled by nature and is very pure, but as it falls on the ground and flows along, or under it, it collects impurities. The latter are either suspended or dissolved. The suspended impurities can be removed by treatment with alum or filtration.

The dissolved impurities in water are again of two kinds :—

- (1) Mineral.
- (2) Organic.

The latter, again, are sub-divided into vegetable and animal.

The mineral impurities render the water hard. This is due to certain salts of Sodium, Calcium, and Magnesium dissolved in it. The hardness due to chalk or calcium carbonate can be removed either by boiling or by mixing lime water in it. But hardness due to other salts cannot be so easily removed. The disadvantages of hardness are that *dhals* (cereals) and vegetables, cooked in it, do not become tender ; hard water is, again, bad for washing purposes, because a lot of soap is wasted first for removing hardness before it cleans dirt. It is believed that stone and gravel in the bladder are produced by it. Hard water does not dissolve soap freely without curdling ; that is its test.

Palatability, or the sparkle of water, is not due to the presence or absence of any salts but to the oxygen and carbonic acid gas dissolved in it. All waters which are pleasant and sparkling to taste are not necessarily pure. The waters which are brackish contain mostly sodium chloride or common salt and to a certain extent other salts. Common salt does not, in itself, make the water hard, but it is generally associated with other salts which render it so. Hence, brackish waters should not be used, especially by the dyspeptics and generally by those suffering from any intestinal disorders.

So far about the mineral impurities some of which, though harmful to health, are not, on the whole, dangerous. But the effects of organic impurities are very serious, and often lead to the outbreak of diseases in the community,

which are called epidemics. By far the most common source of organic impurities is sewage either by soakage from leaking drains, manure-pits, muck-heaps, latrines, etc., getting into the source of supply, whether it be a well, or a stream. Often bodies of dead rats, mice, cats, dogs, etc., float and decompose in water. All these make it very dangerous for drinking purposes.

When a disease in an epidemic form breaks out, it must be due to some poison, either in food or water. Poison in food may affect one isolated family sharing it commonly, but as it spreads to different families, it is a sure indication of the common water supply of the community having been contaminated. Such spreading diseases are Diarrhoea, Cholera, Typhoid, Dysentery, diseases of certain parasites, e.g. guinea-worm, etc. The latter enters the body with drinking water, remains inside it for a year, after which it breeds and makes itself felt in a swollen foot or leg.

#### Sources of Supply and How They are Contaminated.

Household supplies of water are derived in India either from a river or a small stream, a tank, wells or springs. In very rare cases it is derived directly from rain and stored for household use in any large quantities.

Water from rivers and streams should always be looked upon with suspicion. In many instances, the sewage from large towns is let into them. Hence, smaller the volume of water in the river, the greater the quantity of sewage contamination, and the nearer the place from where the water is drawn for use to the source of contamination, the more dangerous the water becomes for domestic purposes. Even small streams and *nallas* or surface water from fields, though they do not receive sewage directly, are still likely to be contaminated by the excreta of animals, including human beings, dead bodies of fish, decomposing vegetation, etc., which are likely to contaminate it.

However, as the rivers and *nallas* flow, the contamination decreases; because a process of self-purification goes on in the running water.

This might be due to the fish and other living organisms in water eating out the organic matter, or to the process of "oxidation" or the destruction by oxygen in the air with which the water comes in contact in the course of its flow. But it is a fact that some miles below the place, where sewage is let into the river, the quantity of water improves. This, however, cannot be entirely relied upon as we do not know what other sources of contamination in the intermediate length there might be.

Tanks and reservoirs collect only rain-water flowing along the ground surface, and therefore, so long as we are not sure that there is no source of contamination from human habitations or cattle in the entire catchment area, from which the rain-water flows into them, purity of supply cannot be

guaranteed. On the contrary, the smaller the tank the greater the chances of contamination.

**Wells :—**Wells are classified into two divisions :—

- (1) Shallow Wells.
- (2) Deep Wells.

A well is called deep, not necessarily because it is deep, but because one or more impermeable layers, such as black earth or clay, intervene and prevent the water percolating from the ground surface reaching it. A shallow well is one which derives its supply from such percolation. In India, with the exception of some of the larger towns, the supply of water for domestic purposes is mostly derived from wells. In some towns and villages, there is a well in every house, either inside the house, or a little away from it, mostly in the backyard. When these wells are first excavated, the supply is pure but gradually sewage and the sullage water, which from the surrounding houses are allowed to seep into the ground, filter through the soil and find their way to the well. It is in the beginning pure, but as the underground strata are gradually polluted and saturated with the organic impurities in the sewage, the filtering media lose their power of filtration and the liquid sewage passes unfiltered to the lower and lower level, and ultimately reaches the water-bearing stratum from which the well draws its supply in the form of pure sewage, making the whole supply dangerous for human consumption. If the well is deep in the above sense, the intervening impermeable layer or layers effectively bars the sewage from entering the water-bearing strata and contaminating the supply.

Even if a well is deep with an assuredly pure water supply, the latter is likely to be contaminated by one or more of the following causes :—

(1) Very often, there are trees overhanging or in close proximity of the well, and the leaves, flowers and fruit from it either drop directly or are blown by wind into it, which decompose and contaminate the supply.

(2) Very often, washing or bathing is done quite close to the well and the dirty water splashes and flows into it.

(3) There is no well-built, properly graded gutter for the waste water to flow away from the well. This causes the water to stagnate in a pond quite close to the well and it percolates into it.

(4) Very often, steps are provided to reach the water in the well. People using them indiscriminately pollute the water by washing hands and feet and even by spitting or gargling in it. Burnishing copper or brass pots with ashes, earth and often road scrapings, and washing them in the well is also a common practice.

(5) The village urchins often bathe and swim in the wells.

Thus wells, in the midst of human habitation, should be looked upon with suspicion unless they are deep, in the technical sense of the word, and vigilantly guarded against the above common sources of impurities.

Wells which are open to the sun and air are preferable, no doubt; but when it is considered that open wells are likely to be polluted in the way mentioned above, it is always advisable to close them and leave an aperture just sufficient for drawing water or close them altogether, and instal hand-pumps for drawing water. This will incidentally prevent mosquito-breeding. Means should, however, be provided for opening the cover for occasional cleaning and repairs to the well and pump.

Deep bore-holes drilled into the ground to tap underground water have always a supply of pure water.

A spring is an outflow of supply of water, situated somewhere at a higher level, from which it flows or percolates by gravity to a lower level through a subterranean path. During its passage it is filtered and hence it is invariably pure. Unlike water from deep bore-holes, it gets a chance of æration and is also palatable.

#### Purification of Water.

The dangers attendant on the indiscriminate use of water from rivers, *nallas* and wells situated in the midst of human habitation, have been dealt with in the previous chapter. Prevention is always better than cure. Hence, it is safe to use water from doubtful sources for cooking and drinking purposes only after it is purified. We are discussing here only the methods on a small scale suitable for domestic supply.

The best and surest method is distillation. But it is expensive and also impracticable. It is possible, however, to collect rain-water in the monsoon season sufficient at a time for two or three days' requirement to meet the breaks in the rain-fall. It may be either collected directly from house roofs as is done at Broach, or similar large surfaces or from fairly pure ground, such as sand or unmanured field or rock, as is done at Aden, away from human habitation. This should be done after the roof or the ground has been thoroughly washed away by previous rain. For, the first flow from rain, collected from roof surfaces, besides containing impurities, such as particles of dust, soot, droppings of birds, leaves of trees, pollens of flowers, etc., also holds acids and ammonia from the atmosphere dissolved in it. To remove the former, the water collected must be well strained through a sand filter. The latter impurities are harmless.

Rain-water is very soft and is specially useful for washing purposes. A very small quantity of soap is required. In some countries, notably in

Holland, concrete or masonry tanks of several months' consuming capacity are constructed and rain-water is stored in them.

The second best method which is more practicable for every household, is to boil the water required for drinking purposes. For perfect purification, the boiling water must actually boil for at least 5 minutes. Though the living organisms in water stand much higher temperature than that of the boiling water, they are killed by the moist heat or saturated steam at the boiling temperature. Hence, boiling is an effective remedy. We have already seen that mere boiling is not effective in removing hardness of water, except that due to the presence of chalk. The third remedy is to filter the water. Filters, if working efficiently, remove both the suspended and the dissolved impurities. In respect of the former, the action is purely mechanical, the voids in sand or the pores in other material, such as coal, etc., offer resistance to the suspended matter which is arrested by them, and only the pure water is allowed to pass. In respect of the organic matter the action is chemical. The upper layer of the filtering material holds a sort of bacteria which eat out all the organic matter in the water, but in the course of a few days the layer becomes clogged and the filter does not work. The sand or whatever other material it is, must then be washed for re-working of filter. When pores in the upper layer are clogged, not only does the filter not work well, but it forms a positive danger; because the growth of fungus occurs on it which makes the water worse than before. Hence, absence of a filter is better than a dirty filter.

The materials commonly used for filtration are sand, gravel, iron filings, charcoal, animal coal, porous stone, ground slag, etc. Sand is by far very common. For efficient working, three grades should be used. The lowest should be of shingle of  $\frac{1}{2}$  inch size, the middle layer of gravel of  $\frac{1}{4}$  inch size, and the upper layer of very fine sand. All these should be carefully washed separately and then used. Ordinarily, filters should be washed once a week. After washing, the material should be exposed to sun for a day and fresh material used instead. The old material should be screened, graded, and used again next week.

Not only the sand or the other filtering material, but the containers used for holding the filtering material and the filtered water, should also be scrupulously cleaned; the former, every week along with filters and the latter every day.

#### Purification by Chemical and Other Agents

**Alum** :—This has no germicidal action; it combines with the alkaline carbonates present in water to form aluminium hydrate, which being insoluble in water precipitates to the bottom.

A sort of fruit called the "clearing nut" (*Nirmali*) is frequently used in India for the same purpose. The fruit is rubbed against the inner sides of the

vessel holding muddy water for a minute and in a few minutes the suspended impurities settle down at the bottom leaving clear water above.

**Potassium Permanganate** :—This does not directly kill bacteria, but destroys the organic matter on which the bacteria live. Still, this is a very sure, cheap, and simple remedy of disinfecting well water during periods of epidemics. When dissolved in water, it produces nascent oxygen which oxidises organic matter.

There are two methods of using it. The first is to calculate the quantity of water in the well or the cistern to be disinfected, and put potassium permanganate into it in the proportion of five parts of P.P. per million parts of water. The other depends on the colour test only. A sufficient quantity is said to have been added, when after half an hour a red colour is still present. If not, add more. In all cases, enough should be added to produce a faint pink colour lasting 24 hours.

The mode of mixing P.P. is as follows : Put the crystals of P.P. in a bucket and fill it nearly half with the water to be treated. Stir it up and pour the red solution thus produced into the well, leaving the portion of the P.P. that is not yet dissolved in the bucket into the well, fill it with water, draw it up, stir it, and pour back the red solution as before. Repeat the process till all the P.P. has been dissolved. One to six ounces will be generally found to be sufficient for average wells. If the P.P. is added at night, the water will be fit for drinking on the following morning. If, at this time, the water has a red colour, it will have a slightly unpleasant taste, but it is perfectly harmless. The unpleasant taste will go away automatically in course of time as water is drawn from the well.

**Bleaching Powder** :—This is a whitish grey powder with a characteristic smell. It consists of slaked lime saturated with chlorine, and is a powerful sterilising agent. The powders available in the market are of varying strengths in respect of the chlorine contained. Again, the dose of the powder required to sterilise a certain quantity of water depends on the amount of the organic matter present. Roughly, one part of bleaching powder of 25 per cent chlorine strength is required to sterilise one million parts of average water. According to this, one ounce of bleaching powder (25 per cent strength) would be required to sterilise water five feet deep in a well of 8 feet diameter.

Make a solution of one ounce of powder dissolved in one pint (20 ozs.) of water, and keep it in a well-stoppered bottle in the dark. The well, treated with it, should be allowed to stand for 24 hours for its action.

The test of the sufficiency of dose is that there should be free chlorine in it which should be appreciable to the taste. The presence of free chlorine can be tested also chemically by adding Potassium Iodide and starch to the sample of water when a bright blue colour will appear.

The advantage of using bleaching powder for disinfecting water is that its disinfecting action is completed rapidly in about 20 minutes and that complete disinfection can be obtained *without* taste or smell or colour. The taste and smell usually experienced in chlorinated water is more due to chloramines resulting from the action of chlorine on organic matter of polluted waters than to the presence of pure chlorine, which may be demonstrated by the other means than taste and smell. Excess chlorination will produce taste and smell of chlorine, but it is unnecessary to proceed to such excess.

**Chlorogen** :—This acts in the same way as the bleaching powder, by liberating chlorine and nascent oxygen which are both very powerful sterilising agents. Chlorogen deteriorates in strength on keeping for a long time. The amount of chlorogen required depends on the degree of contamination. Hence, a rule of thumb cannot be applied for its use. The method of determining the quantity of chlorogen to treat a certain well is rather complicated. Roughly, if a perceptible taste of chlorine is felt after 12 hours in the water treated, we err on the safe side.

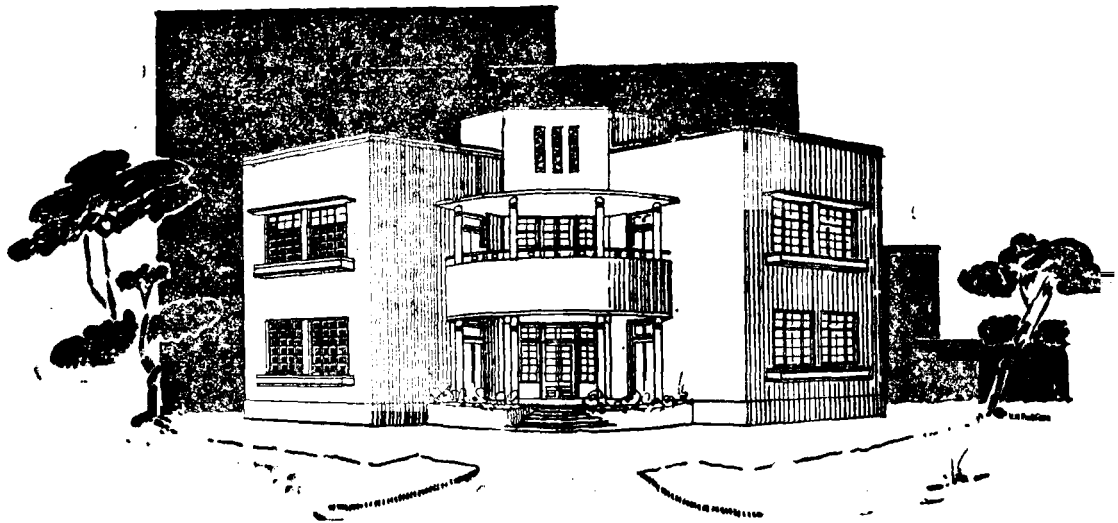

## House Cleaning : XV

If one starts to clean a house from one end, before one reaches the other, the house is again ready for cleaning. We have thus to wage a war continually against dirt, and our enemy is such that it is impossible to completely vanquish him. At the most, we can keep him under control. The moment of our rest is the moment of our defeat. Nevertheless, if a habit of perfect cleanliness is once acquired, it becomes second nature and the very sight of dirt becomes unbearable. There is some indescribable pleasure—a sense of supreme satisfaction arising from cleanliness and the person who has once realised it, becomes so sensitive to it that he feels a sort of positive discomfort at the sight of dirt.

A house may have been designed and built on the most up-to-date hygienic principles with the best of materials and supplied with every ultra-modern appliance of comfort and convenience, but if it is not maintained in a clean state, it may soon be rendered unfit for human habitation. Hence, cleaning the house, both inside and outside is a matter of utmost importance.

Prevention is always better than cure. If, therefore, every one in the house would do his or her bit, not necessarily in cleaning, but by preventing dirt by the practice of cleanly habits, it would go a long way towards success. Even young children should be trained to do so from their early age, which then becomes a part and parcel of themselves.

Method and system are, as in everything else, the key-note to success in this matter also. They consist in having a clear idea of what is exactly to be done, and in pre-arranging as to when, how and by whom exactly it has got to be done. If the person concerned is made to feel his or her responsibility, success would be guaranteed. An important point is the division of labour. There is nothing derogatory or undignified in doing part of it oneself. On the contrary, if the important person in the household shows occasionally a keenness on doing it personally, every one else in the house catches the spirit of dignity of labour, and the servants, too, do not get an opportunity to scamp work.

In order to maintain a house and its premises in a perfectly clean state, certain rounds of duties have to be done daily, weekly, monthly, and periodically. As a general rule, daily work must be directed towards removal of fresh dirt, which is continually collecting on surface, and the weekly and periodical cleaning must aim at restoration to that condition of perfect cleanliness from which everything around us tends continually to depart.

Out of the daily duties, sweeping dust, and collecting, removing and disposing of the refuse produced inside and outside the house is an important one. Dust must be removed not only from the floor, but from every surface which is likely to collect it, such as wall surfaces, picture frames, furniture, etc. First, take the door mats and carpets away from the house, shake and beat them with a stick, then close all the doors of the room to be cleaned so that the dust may not enter other rooms, sweep the floor, then spread the carpet again in position, wait for a few minutes for the dust to settle down and then dust the pieces of furniture, etc. The usual practice of doing the latter consists of beating the surface briskly with a piece of cloth tied to the end of a rod. This does not remove the dust, but helps distribute it evenly on the surrounding articles in the room. The proper way of doing it is to wipe the dust off, gently and carefully with a piece of moist cloth which should be shaken frequently out of the window.

The rooms used most are likely to be most dusty. The main entrance passage is thus the worst in this respect, then comes the staircase if there be one in the front, because, it is the only thoroughfare for going up. It was formerly the custom enjoined by the Hindu Shastras to wash one's feet with water before entering the house. For if we walk out of doors we are sure to bring in with our feet, some of the dirt from the street. What this dirt shows itself to be under a microscope, has been already described on page 93. It is pity, however that many of us, in blind imitation of the Western people, enter even the innermost apartments with shoes on. With the proper use of a scraper at the front door, and a mat in the front passage, the danger is considerably reduced. However, it is the best custom to remove shoes near the entrance and then enter inner apartments with indoor slippers, if necessary as is the practice in a Japanese home. The dust from the entrance passage and stairs which is full of harmful bacteria, must not be allowed to enter other rooms. These rooms should be cleaned first in the morning after closing the doors of the adjoining rooms.

As a general rule, all living rooms should be cleaned daily. The bedroom in which we pass nearly one-third of our life should be kept particularly clean. This should be sunned every day by opening out windows and admitting sun's rays, especially in the morning if this be possible.

The stair should be started from the top downwards, but not in a manner as to push the dust by a brisk sweep of the broom. Every step should be wiped gently with a broom, or better still, with a round brush which penetrates into corners better, and the dust from it collected in a pan held below the edge.

All the ledges in doors, windows, etc., should be wiped clean ; lamps, flower-pots, ornaments forming articles of decoration etc. should be wiped, rubbed, and polished.

Bedding and coverings should be aired every day for a few hours and sunned once a week, together with the bed taken to pieces. A searching examination should be occasionally made of joints, folds, etc., to search if any bugs have intruded, and if so, prompt action should be taken to inject 5% D.D.T. ; then close the joints with wax and spray D.D.T. to destroy their eggs.

Emptying slop basins or cisterns should also form one of the daily rounds of duties. All the open drains should then be examined and obstruction, if any, removed.

Among the weekly duties come the sweeping of the wall surface corners and ceiling etc., removing cob-webs and dust, washing floors, urinals, and sinks with a disinfectant, and scrubbing and washing shelves in the kitchen cupboards.

Household dustbins should preferably be of iron and they should be disinfected by burning waste paper in them.

Bath and toilet rooms should be white-washed twice a year. If freshly slaked lime is used, it behaves as an excellent disinfectant. If trouble of bugs is apprehended, the bedrooms should be given a buff wash made of freshly slaked lime mixed with *Multan Mitti* or some such cheap colouring pigment, so that it can be renewed at a small cost from time to time, with a view to killing all the vermin.

Kitchen walls of the houses of the middle classes, in which firewood is mostly used for fuel, are likely to be dark on account of the smoke. The best plan is to give a cheap yellow lime wash, or better still, two coats of a paint prepared in the following manner :—

Pour water on freshly burnt Surat lime (lime prepared by burning sea-shells in a kiln) to make a wash of the consistency of cream, mix boiled linseed oil with it in the proportion of one part of linseed oil to 8 parts of the milk of lime, and give a wash with it by means of a vegetable fibre brush, as lime will act on animal bristles and soon destroy the brush. The surface, when dry, can be frequently washed with a disinfectant without losing the colour. This paint lasts for a long time.

## A Few Chief Disinfectants and Their Use : XVI

From personal knowledge, the writer is led to believe that even many educated people have got a wrong notion about disinfectants. Many people think that a substance which conceals or destroys an offensive smell emanating from decomposing matter is a disinfectant, and with this mistaken idea, they entirely rely upon them under a delusion which gives them a sense of false security. It is therefore proposed to close this section after making a brief reference in this chapter to a few cheap and reliable disinfectants.

*Disinfectants* are agents which destroy the germs or the carriers of the germs of disease, and should be distinguished from the *antiseptics* which merely check the growth of the germs and prevent animal or vegetable substances from decomposing, and from *deodorants* which oxidise the products of decomposition as soon as they are produced, and so absorb or destroy offensive smells.

It is not enough to know that a certain substance is a disinfectant; the quantity to be used and the degree of concentration necessary for its successful operation are also important factors.

(1) **Fresh air and sunlight** are the natural disinfectants and kill germs of most diseases. The only disadvantage is that whereas clothes, mattresses, pieces of furniture and other movable articles can be exposed to sunlight, and disinfected, the corners and recesses of rooms cannot, for which some other convenient disinfectants have to be sought for. For systematic disinfection by sunlight the following rules should be observed :—

Select a flat piece of ground with no cracks in it. It should preferably be sandy, or else, sand may be sprinkled on its surface.

Let it get hot by exposure to sun. Thus sun disinfection should not be attempted before 11 o'clock in the morning.

Spread clothes on it evenly in a single layer. If they are left exposed to sun in this way even for an hour that is enough. Thick padded clothes, such as quilted coats, mattresses, etc. must be turned over once or twice so that both the sides are well heated. Beds and pieces of wooden furniture should be taken to pieces, if possible, and exposed to sun for several days.

(2) **Quicklime** is the next best agent for disinfection. It is cheap, and has a very high germicidal value. Water should be sprinkled on freshly burnt *kunker*, till it falls to powder, which is called slaked lime. This may be used either in a dry state or formed into a liquid of the consistency of milk by dissolving it into water, and then used in that condition. It can be used

to purify water, to disinfect floors, stables, drains, gutters, etc. The powder soon absorbs carbon dioxide from the air and deteriorates in quality. Hence stale dry lime is useless.

(3) **Phenyle** :—This and carbolic acid are both obtained from coal-tar, but phenyle is twice as powerful as carbolic acid, besides being much cheaper. It is, however, poisonous and irritant to the skin. One part of it in 50 parts of water forms a good disinfectant.

(4) **Izal** is also obtained from coal-tar. It is non-irritant, non-poisonous and cheap, and is thus superior to phenyle in every respect. One part of it in 500 of water disinfects even the stools of a Typhoid patient in 15 minutes. (Dr. Klein).

(5) **Pesterine** is a strong disinfectant and comparatively cheap. It does not mix with water, but does so freely in soap solution. The objection to its use is that it stains fabric. One part in 100 of water makes a sufficiently strong disinfectant.

(6) **Fumigation by Sulphurous Acid** :—This is also a very effective and comparatively cheap method, and possesses some special advantage over other disinfectants in so much as it kills all the germs floating in the atmosphere contained in a room. But as it is a poisonous gas, it cannot be used when the room is occupied. There are special machines designed for this purpose but the pot method is the cheapest and easiest for household use.

First take powdered sulphur, in the proportion of 2 lb. per 1000 cubic feet capacity of a room, moisten it with methylated spirit, and put it into an iron pot. The latter should be placed into a tub containing water. The tub should be placed high up in the centre of the room, say at 5 or 6 feet above the floor. Before igniting the sulphur, all the doors and windows, etc., should be closed. Even the chinks and cracks in them should be closed by pasting paper on them. Then ignite the sulphur, and let the smoke emanating from it fill the room for six hours, when the doors and windows should be opened.

The water is required for supplying the necessary moisture to produce hydrated sulphur dioxide ( $\text{SO}_2$ ) and it is to be burnt at a high level because the sulphur gas, being heavier than air, will sink to the bottom and will not reach the higher parts of the room.

Ready-made sulphur candles can now be had in the market for this purpose which are very suitable.

While using sulphur as a means of disinfectant, it should be noted that its gas bleaches all colouring matter of vegetable origin, acts on cotton and linen fabric and attacks all metals, especially silver, which it stains very badly.

As a general rule, disinfectants act better at high temperature. The water to be used should therefore be hot. Hard water interferes with the

property of disinfection. Hence, only soft water should be used. Again, an emulsion is more powerful than a mere solution.

A bucket spray pump does the work of disinfecting very satisfactorily and economically.

(7) D.D.T. (Dichloro-diphenyl-trichloroethane) :—This is not a disinfectant, but a powerful insecticide. It is colourless, odourless, crystalline substance, which can be used either by dusting mixed with chalk talc, etc., or by spraying in the form of a solution in water, kerosene oil, naphtha, alcohol, etc. Usually a 5% solution in kerosene oil is used and is found cheap and convenient for all practical purposes. Experiments have proved that a 20% solution is more economical in the end as it is more than four times effective than 5% mixtures. Surfaces of walls, tables, chairs, etc. treated with it will remain poisonous to all household insects for 3 to 6 months. Underclothes, once dusted with it will protect the wearer against lice carrying germs of typhus and other diseases, through as many as eight launderings.

Its action lies in attacking the nervous system of insects. Flies, bed-bugs, mosquitoes go as if in drunken jitters after contact, and this is soon followed by paralysis and ultimate death. Flies and mosquitoes die within half an hour, bed-bugs, in 3 to 4 hours. For killing cockroaches the concentration should be at least 10%.

Though it is a poison when swallowed, human beings and animals need not be afraid of it. The only precaution required is not to leave foodstuffs and vegetables uncovered when it is being used. A 10% powder dusted into hair will kill all the hair lice. Woollens and furs can be protected if they are dusted or sprayed with a 5% mixture.

Cats, dogs, cows may be dusted with 5% powder to protect them from fleas, lice, ticks etc. If the animals are washed frequently, the dusting or spraying must be repeated. It is desirable that as the cat licks its body, only the head and neck should be treated.

It is an effective remedy for the eradication of malaria. The breeding places such as stagnant ponds, ditches, marshy places etc. must be sprayed once a week till all the larvae are killed.

---

## Repairs and Alterations : XVII

The subject of repairs is so vast that in order to do full justice to it, a volume, perhaps bigger than the present one would be required. In the present chapter it is proposed only to touch on the aspect of [remodelling a building] which is in need of repairs with a view to improving the general sanitation connected with it.

From this point of view, (an examination of the existing drainage system occupies the first place of importance.) A defective drainage, whether closed underground or open at surface, makes itself visible, first in the evidence of damp, and then in that of a bad smell caused by the emanation of foul gases. This may be due to a crack in the drain or some obstruction in the passage of the water flowing through it, which causes the water to head up, soak in the ground and overflow if it gets an outlet. The smell even inside bathrooms in some Indian homes is so bad sometimes that it is an ordeal to stand there for a few minutes. Even flushing the bathroom with a copious supply of water does not remove it. The reason is that the obstruction which chokes the drain is in a state of decomposition, and the foul gases given out by it enter the room and cause the smell.

The first precaution against this is to provide traps at every drain in the house so as to cut off the connection between the interior of the house with the outside drain. A *nhani* trap has already been illustrated on page 126. In places where water-carriage system has been introduced, the municipal authorities compel the owner by law to provide systematically designed drains with traps, ventilating pipes, etc., but even in places where a system of open surface drains exists, provision of traps would go a long way towards improving general sanitation. The next thing is to give a suitable fall to the drains so as to create a self-cleansing velocity in the flow; and the third essential is the provision of means of access to the drains for inspection or repairs, if the drains be wholly or partially covered underground. This subject has been treated at considerable length in the author's *Build Your Own Home*.

(Eighty per cent of the damp is caused by defective drainage, 15 per cent by leaky roofs, and only 5 per cent by all other causes combined.) In the case of flat roofs a not uncommon cause of damp is the neglect of the periodical inspection and repairs of the cracks on the surface of the terrace or valleys and roof gutters and in the brickwork and coping of the parapet walls. The damp due to these causes is visible by stained patches on the surface near top of walls.

The following are the remedies suggested for this :-

- (a) If the roof be of mud, and if impervious white earth be not available, keep the surface with a mixture of 12 parts of roofing earth, four of cow-dung, and one of cement mixed in water and moderately rub the surface with the mason's trowel. This will, in most cases, be found to be effective, but if it does not stop the trouble, (apply, when the surface is dry, a coat of the paint prepared of sodiumised clay\* mixed with boiled linseed oil.)
- (b) If the roof be of cement or lime concrete terrace, and if the cracks are very fine, called 'hair-cracks', then
  - (i) Give a coat of cow-dung, cement, and fine sand, mixed in equal proportions in water, with a brush. This should be applied in the evening so as to give it a chance of setting slowly.
  - (ii) Paint the cracked surface with hot bitumen, or cold "Colas". The remedy is effective but it stains the surface dark.
  - (iii) Mix cement in linseed oil and apply hot with a brush. )
- (c) If the cracks are wide,
  - (i) Take linseed oil two lb., and while it is being boiled, add one lb. of resin crushed to powder and then powdered bath brick or very fine sand one lb., and apply the mixture with a brush while hot.
- (d) If the cracks are big, widen them further by means of a chisel, ) remove every bit of loose stuff and wash them clean with water. After this, fill in by pushing hard by the edge of a trowel, a mixture composed of cotton waste, cut to pieces, thoroughly soaked in hot asphalt or bitumen, spread some also on the surface and wipe it off with a trowel.)

Another item of frequent repairs is the plaster. If it be of lime, a very careful treatment is required because it is very difficult to make a proper junction between the old mortar which has already set and the fresh one. Open all the loosened patches, rake out the joints, soak them freely with water which should be beaten in with a brush dipped into water and then apply lime mortar, in which cement is mixed in the proportion of 5 of mortar to 1 of cement. This would make the surface sufficiently hard in about 3 to 4 hours, when it should be tamped closely with an edged instrument and then coated finally with a mixture consisting of cream of lime and fine sand in equal proportions ground

---

\* Vide pages 16 and 17.

sisting of cream of lime and fine sand in equal proportions ground to a workable paste with a pestle on a flat piece of stone, applied with a trowel and polished.

(If the plaster be of mud, dismantle the patch which sounds hollow, moisten the portion with water and replaster it with sodiumised clay or brick clay, in which is mixed, cement in the proportions of one of cement to 12 of clay. This should be indented as described above and finished on with a final coat of the same material.

(Another item of repairs, which is often very troublesome, and causes damp and consequent ill-health is the leak through the walls and floor in the cellar or basement floor. The entire surface of the wall and floor should be minutely examined under the light of an electric torch, if the daylight be insufficient in such a room, to see whether any cracks are visible and whether water leaks through them and if so, they should be treated in the manner described for repairing leaky terraced roofs. If there be no cracks, and if the water is seeping through the pores of the permeable concrete, the remedy suggested on page 92, viz. excavating a trench on the outside of the wall in the portion through which water leaks, pointing the joints with cement, and in addition, filling the trench with black cotton soil well rammed may be resorted to, or a coating of cement plaster may be applied.)

If the floor of the basement is seeping, it is rather a difficult job to set right, because the water coming inside is in most cases under pressure. Any surface treatment, therefore, is of no use. The only satisfactory remedy is to construct a new floor on the top of the old one with cement concrete, taking all the precautions to ensure a compact and water-tight surface. Some water-proofing compound may be mixed in the concrete.

## Type Economical Plans : XVIII

A few economical type plans are given below illustrating some of the

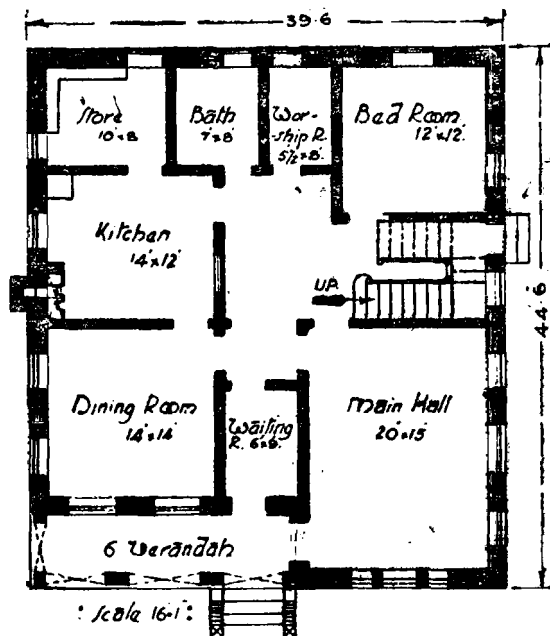

: GROUND FLOOR PLAN :

Fig. 73.

Diagonal dotted cross lines indicate arches; Double lines along walls near the outer edge, windows; Recess in walls, cupboards; Breaks in walls, doors; Steps with arrow, staircase; CH. chulla; S, sink; SF, Shelf; Rectangular fig. in bedroom, position of bed. N, (The arrow on the right, in the front) shows the North direction.

principles of economy mentioned in the foregoing pages. Economy consists of two sorts : first in planning, and the second in construction. Economic planning consists of grouping of the different apartments in such a way that no space under the roof is wasted, a minimum possible being allotted to passages and lobbies in order to make every room (except perhaps the drawing room), and particularly, the bathroom and services, independently approachable. This has been attempted to be done in the few plans given below.

The plans are self-explanatory; still, for the guidance of laymen who have never seen building plans, explanation of the details is supplied under the keyplan in Fig. 73.

The costs given at the head of each plan are based on the average of the current rates in different provinces. The cost

of construction began first to rise in 1943, and has kept on steadily increasing to the present day. Whereas the cost of labour both skilled and unskilled, and cost of materials such as lime, timber, cement etc. has gone up to three times, that of steel and some hardware materials has risen from six to sixteen times and on the whole that of the construction, from 2½ to 3 times the pre-war rates.

Wherever pitched roof is indicated, roof lines have been shown in dotted lines on the plans. As the plans are intended for up-country places, latrines are expected to be built a little away from the main building. They are therefore not shown in many cases. The cost includes the main building only. Site, out-buildings, compound wall, water and sanitary fitting and electric wiring, etc., would require an extra amount.

PLAN No. 1.

(Plinth Area 1170 Sq. Ft.)

(Cost Rs. 5700)

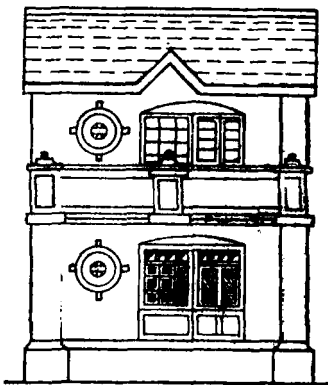
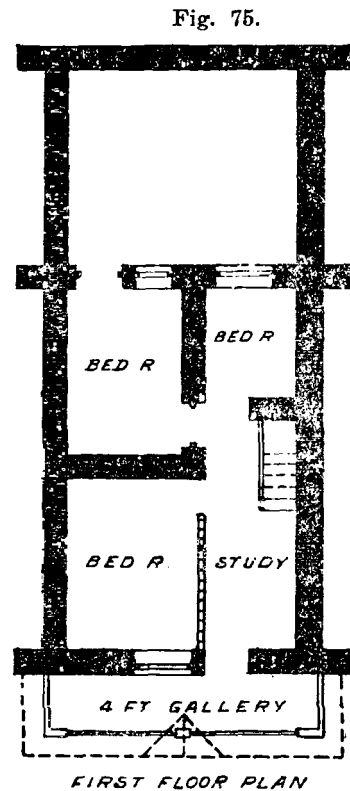
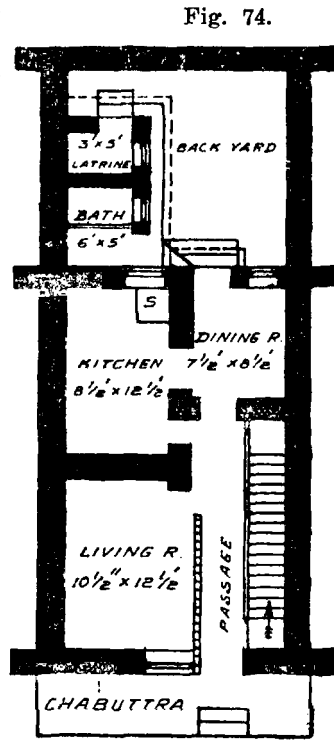

FRONT ELEVATION

Fig. 76.

Very often, the sites for buildings, lining streets in towns are long with a very narrow frontage, and further, the side walls of the houses either touch each other, or there are no separate side walls to each house, but one wall serves the common purpose of two adjacent houses. Under such circumstances, it is impossible to derive light from the sides. The plan in Figs. 74 to 76 shows how this difficulty is overcome, and how by skilful designing maximum light and ventilation can be secured.

There is an open porch or *chabuttra* in front. If this is enclosed by a low compound wall, it can be used as an excellent conservatory. Of course, only dwarf varieties of plants must be grown, otherwise they will darken the drawing room by shutting off light partially. As one enters the front door,

there is on the left side, a drawing room well lighted by the large window on the front side. Behind it, is the kitchen which has to be contracted a little to make room for the dining room. The kitchen is lighted by a window from the back side. On the rear side there is a closed bathroom and a latrine, the latter has an opening on the opposite side in order to lessen the trouble of flies, should the door remain open by chance. The staircase in the front is 3 feet wide and is very easy to ascend.

Upstairs (Fig. 75) are three bedrooms, a study room, and a projecting gallery in front. All the rooms are so skilfully grouped that each has an independent entrance, and the gallery, which is an excellent sitting-out place, is independently accessible from every bedroom. Thus, every inch of the space available has been utilised for living accommodation.

The elevation (Fig. 76) is smart and attractive, but if there are a number of such houses on the street, many alternative forms in pleasing diversity, can be adopted in order to break the effect of deadening monotony.

#### PLAN No. 2.

(Plinth Area 1088 Sq. Ft.) (Cost Rs. 4700)

This small but simple and attractive countryside building combines

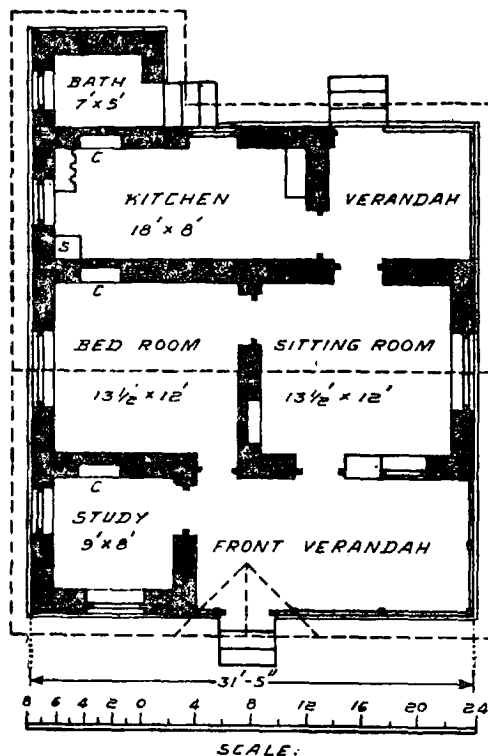

Fig. 77.

economy, comfort and convenience in one place. The verandahs are an Indian institution, and no house, though small, is complete without them. The present cottage has them both in the front and rear, and as they are closed by trellis work which admits light and breeze, they constitute delightful sitting-out places affording the best privacy. The study-room in the front can be used also as a bedroom. The two central rooms are spacious, and the very wide windows provided in them give them a feeling of light and airiness. The elongated kitchen, with two windows, a sink, a shelf and a cupboard with a wide verandah in front, should prove a thing of constant pride and joy to the housewife. It would ordinarily provide the necessary accommodation for the members of the household to dine together. The front verandah which is 9 feet

wide, would accommodate at least five beds and still leave sufficient room for a passage in an emergency.

The distinguishing feature of the cottage is its cheapness. In spite of

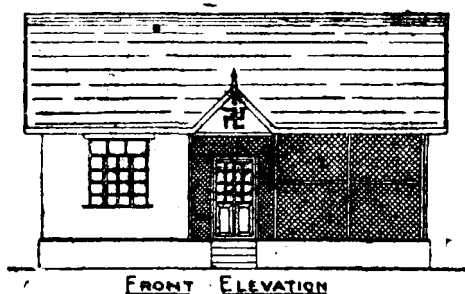

Fig. 78.

the provision of a damp-proof course, rat-proof construction, fully glazed windows, concrete floor throughout, leak-proof roof of corrugated sheets, etc., the building cost only Rs. 4700/- which is worked out in detail. The rate per square foot of plinth area worked out to Rs. 4.33. For preventing heat of the roof, one of the remedies suggested in the chapter on Roof might be adopted.

#### Important Specifications For Plan No. 2.

The foundations are taken down to hard, stable earth, 3 ft. deep and filled with rubble in mud.

**Uncoursed Rubble Masonry in Foundation and Plinth** :—Please see page 31 in respect of headers, bedding of stones, and precautions against hollows in the wall, etc.

**Damp-proof Course** : This is to consist of a  $\frac{3}{4}$  inches layer of concrete of gravel, sand and cement with a layer of coal-tar on it, laid on the top of the plinth masonry which is 2 ft. high. (vide page 26).

**Concrete Flooring** :— The space below the plinth to be filled with any earth except the black cotton soil (*Regur*), and should be thoroughly rammed and watered. On the top of this is to be laid, a 3 inch layer of concrete consisting of stone pebbles from river bed below  $1\frac{1}{2}$  inches size 4 parts, unscreened sand from earth 2 parts, and lime mortar 1 part. If metal or pebbles are not available broken brick-bats should be used. This layer to be rammed hard, and while yet green, a  $\frac{1}{2}$  inch layer of mortar prepared of 32 parts of sand, 8 parts of lime mortar, and one of cement should be applied on top and moderately polished as the mortar sets. This is to be kept moist by spreading wet grass, frequently watered for 15 days.

**Doors and Windows of Teak or Salwood** :—The frames to be made of R. C. C. as described in Appendix No. 3.

**Light doors** :—The frames to be of R. C. C. as above. The shutters to be of a frame of teak wood 1 inch thick with panels of waterproof canvas stretched and screwed on to it by means of wooden fillets. (vide page 58).

The shelves to be of whole piece flagstones such as Shahabad, Tandur, Yerraguntla, Katni, Rewari etc., with the front edge rounded.

Wire-netting for 18 inches Skirting :— The lower end to be embedded into concrete floor at least 2 inches and only when the concrete has set, should the upper end be stretched well and the netting fixed on the surface of the wall by means of U-shaped staples, 1½ inches long, driven into the wall. The surface to be plastered over with mud again and leaped over with cow-dung. (Page 55).

PLAN No. 3.

(Plinth Area 1326 Sq. Ft.) (Cost Rs. 5800)

This snug little cottage, on account of the broad, low sweeping lines in

Fig. 79.

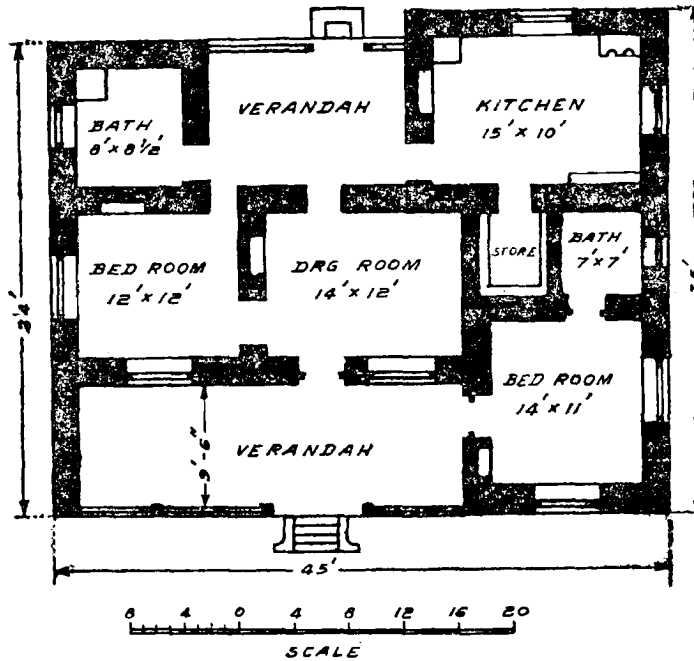

the elevation gives an appearance of roominess. The deep verandah in front is most inviting. It gives a feeling of a little out-of doors, and yet the dwarf wall on its edge affords a touch of privacy. The drawing room, centrally situated, will give the necessary warmth in winter and coolness in summer. The bedrooms are commodious and are provided with separate bathrooms—a modern necessity. The kitchen is not only sufficiently spacious but provision of a separate store-room, with rows of shelves, adds to its convenience. The wide verandah enclosed by trellis on the rear side would provide an excellent dining-room. The bathroom is very conveniently situated.

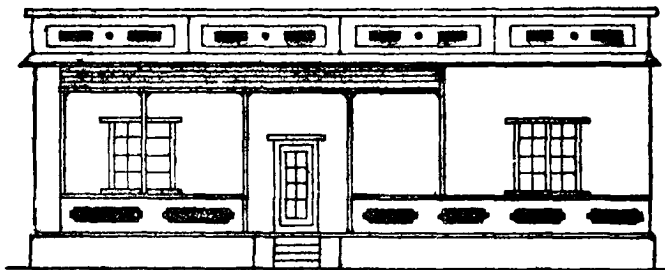

FRONT ELEVATION

Fig. 80.

This bungalow should be built on a slight elevation and should be in a setting of a garden in front, which would then command a view from the verandah and the front bedroom. An ample provision of cupboards has been made in every room.

PLAN No. 4.

(Plinth Area 1462 Sq. Ft.) (Cost Rs. 6600)

This charming little cottage which is designed on the principles of the Indian architecture possesses all the advantages of the latter, without sharing a single disadvantage. The open space in front is enclosed by a high compound wall and is entered through a massive wide gate (not shown

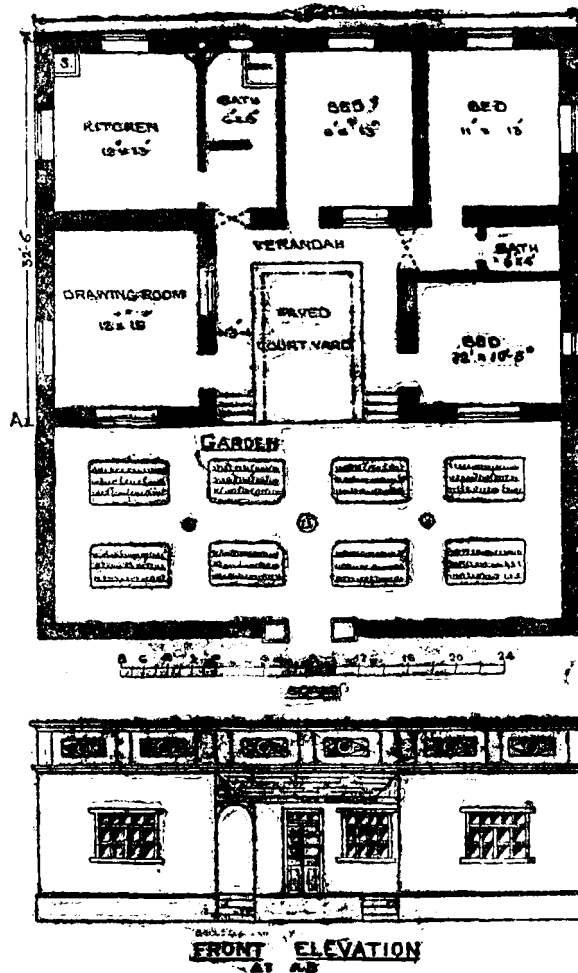

Figs. 81 & 82.

in elevation). There is, again, an open paved courtyard in the centre, round which runs a corridor to give an independent access to every room of the house. Light and breeze pervade the entire house, and with them, health and cheerfulness must predominantly rule, because there is not a single room, even including the kitchen, which is not open at least on two sides; still the house possesses the best privacy from the highways and byways. Imagine the front

garden to be bristling with roses and an exuberant vine trailing on the arch in front of the open paved court-yard and you have to picture to yourself how the cottage would look in this best setting.

The interior arrangements fully synchronise with these exteriors. The sizes of all the rooms are very good for a small cottage like this. There are two bathrooms, each of which is independently accessible from any room. The drawing room and the bedroom opposite to it enjoy light and breeze on three sides. In spite of this all, the cost is only Rs. 6600/-; the garden and compound wall would cost extra.

**PLAN No. 5.**

(Built-up Area 1766 Sq. Ft.) (Cost Rs. 8400)

To one of limited means, who has spent years of his life in cities in the

course of service, or business, in urban buildings, but who now wants to lead a life in retirement with his large family in a town on the country-side, this design will make a strong appeal, because it combines economy with refinements of arrangements and comforts, almost amounting to luxuries. It illustrates the principle that simplicity and straightforwardness of design make not only for economy but also for comfort and health.

It is a storyed building with a flat roof on. But a pitched roof would give the elevation even a better effect of simplicity and homelike appearance as the plan is a straightforward rectangle, approaching a square.

Ascending the flight of steps, one enters the verandah. If funds permit, it is worth while projecting the verandah a little more so as to make it 8 feet wide at a little extra cost. The good-sized drawing room is provided with four large glass windows which command a view of the landscape on two sides. Behind it is a bedroom with three large windows and two fixed wardrobes. It is of such a size that one living even in a mansion should envy. The spacious kitchen on the right-hand side possesses every modern con-

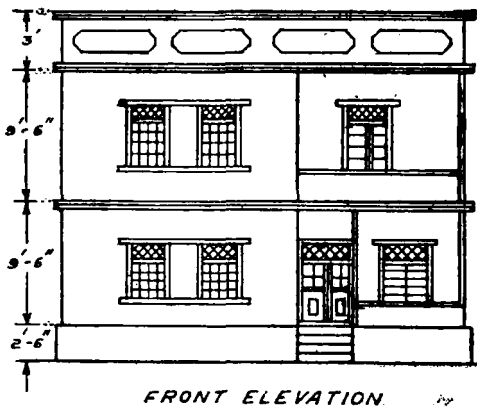
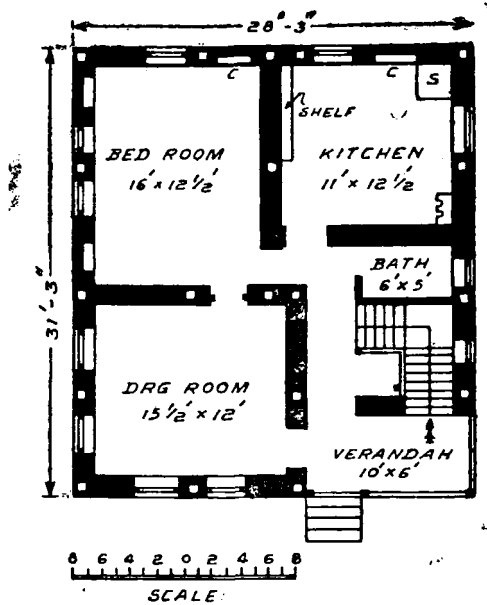

FRONT ELEVATION

Figs. 83 and 84.

venience. If necessary, a back door may be provided in it in the corner of the shelf. The bathroom entered through a lobby is accessible independently from every room. The space below the staircase can be utilised for storing bicycles or a pram. There is a large-sized loft provided (shown in the cross section in Fig. 86) above the bathroom for depositing lumber or storing fuel.

The entrance to the staircase is through the verandah and it lands one in the lobby on the first floor. This may be optionally altered and the entrance may be made through the lobby on the ground floor with a landing in the verandah upstairs. This would save a door on the ground floor.

On the first floor there are three bedrooms, a bathroom, with also a loft on its top, and a verandah. There is an independent passage to every bedroom through the lobby, and the front verandah and the bathroom are common and independently approachable from every bedroom.

The roof, which consists of a 6 in. cover of mud on top of corrugated iron sheets, is bound to remain cool, absolutely leak-proof, and free from the danger of being blown away by a storm. Not only the staircase, but also the posts, floor, ceiling are all of fire-proof material. In fact, no wood is used in the building except for the shutters (not even for frames) of doors and windows. The upper floor and the roof are supported on a framework of teak or sal round rafters 5 to 6 in. diam. embedded in the walls. The white dots shown in the walls on the plans denote their positions. All this makes the building so strong that with the usual attention to the annual maintenance, the building can be guaranteed to last at least 100 years.

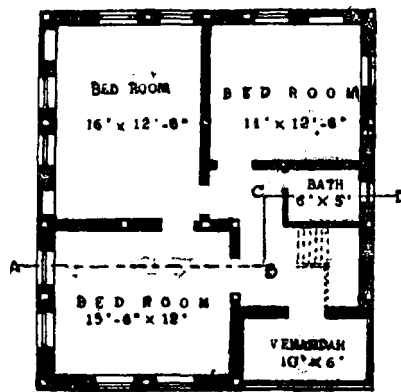

FIRST FLOOR

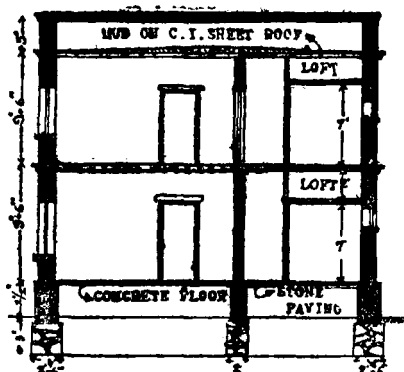

SECTION ON ABCD

Figs. 85 & 86.

Still, the cost of the building does not exceed Rs. 8400 in Bombay State and should be much less in Northern and Southern India. This has been made possible only by adopting some of the measures of economy suggested in the foregoing pages. A reference to the specifications attached is invited for verification of this fact.

**Important Specifications For Plan No. 5.**

*Foundations* : 3 ft. deep carried to soft murum or firm soil, other than black cotton soil (*Regur*) filled with rubble and boulders in mud 2' 9" wide.

*Plinth* : Rubble stone in mud masonry 2 ft. high 18" wide pointed with cement on the exposed face.

*Framework* : Teak or Sal round posts and post-plates 5" to 6" diam. with 9" bottom ends embedded in cement concrete 1:3:6.

*Superstructure* : Burnt brick in mud 1½ brick thick, cement-pointed on exposed faces.

*Partitions* : Sundried-brick-in-mud 9" thick except those round bathroom which are 4½" B.B. in cement mortar 1:4.

*Doors* : With frames of R.C.C., teak or sal shutters in exposed walls panelled 1½" thick, those of inner ones 1" thick with asbestos cement or canvas panels.

*Windows* : Teak or sal frames iron-barred and glazed shutters with iron fittings.

*Lintels* : of flat brick arches in cement mortar.

*Flooring* : 1 in. cement concrete on 3 in. lime concrete of stone or brick-bats.

*Plaster* : Cement plaster 1 ft. high at bottom with embedded wire netting all round inner walls for rat-proofing and mud plaster above.

*Upper Flooring* : Reinforced brick in cement slab 4 in. thick with 1" Cement Concrete above.

*Staircase* : of R.C.C. (please see pages 65, 66).

*Roof* : G. I. Sheets on top of steel joists laid to a slope, with 6 in. rammed mud of white earth on top.

## PLAN No. 6.

(Built-up Area 2704 Sq. Ft.) (Cost Rs. 17500)

This plan is rather on a pretentious scale. It is given here not so much as an example of economy but to illustrate the principle that well conceived simplicity and attention to details in the internal arrangements are the key-note of a good design which makes for the comforts of a real home.

The delightful semi-circular front verandah enjoys a vista and breeze from three directions. On the left side there is a guest room with the modern necessary convenience of a bathroom attached to it. The drawing room is located in the heart of the house and occupies the spacious square room. On the right hand side there is a large verandah 11 feet wide including the space occupied by the stairway. This verandah may, if necessary, be partly enclosed and a small study room formed out of it. The kitchen with ample cupboard space and two windows is compact and convenient and the additional feature of a smoke outlet in a corner adds much to its value. In front of the kitchen and behind the drawing room is

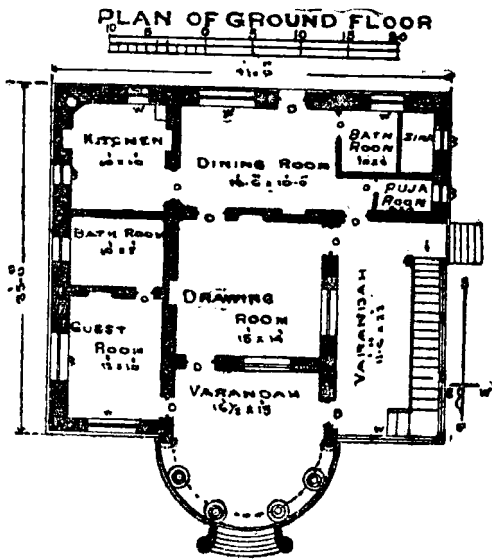

Fig. 87.

placed the commodious dining room and the right hand corner is occupied by a bathroom of convenient size. The small space between the bathroom and the verandah is enclosed and formed into a small *Puja* or Prayer room. Removed away from the hubub of the rest of the house, this small corner will not fail to give that pleasure and peace of mind which the religious-minded person longs to seek in solitude in this materialistic world.

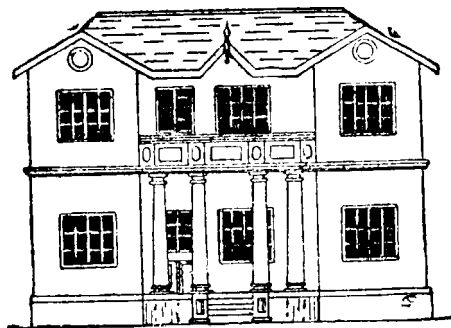

Fig. 88.

For reaching the dining room the guest need not pass through the drawing room, but through the verandah on the right side and enter through the door

near the Puja room. If a separate bathroom is not required to be attached to the guest room, it would be an excellent plan to turn it into a store room for the kitchen. All that is necessary for this is to close the door communicating with the guest room and open another in the wall between the kitchen and the store room.

The staircase is wide and easy to climb and all built of fire-proof material. Upstairs there are three bedrooms, the special feature of which is that each enjoys free breeze from three sides and that the small bathroom can be entered independently from every bedroom through the lobby, and further that the verandah and open terrace also can be made use of by the occupiers of the bedrooms quite independently.

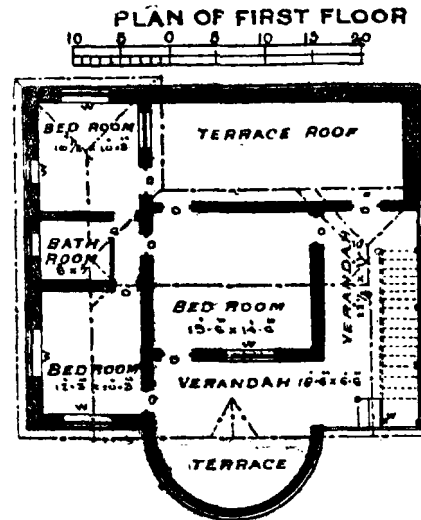

Fig. 89.

If a small bed or study room is built on the right-hand side of the open terrace on the rear side, it would be open on all four sides.

If the same arrangement of rooms as on the ground floor is made upstairs and the latter flat let as a separate tenement, the independent entrance to the staircase on the left-hand side would admit even of this.

With all these conveniences and special features the cost in an upcountry town for a solid structure of stone or brick-in-lime walls, paving of Indian Patent stone floor in the entire house, R. B. C. suspended flooring, R. C. C. round posts in the front verandah, fully glazed doors and windows, asbestos cement roof, etc., the cost should not exceed Rs. 17500.

Thus, this cottage rightly combines symmetry, simplicity, dignity, comfort and economy all in one. This was actually built at Nasik in the Bombay



Fig. 90.

State on the Bombay Agra Road, at a cost of Rs. 7000 in pre-war days. Fig. 90 shows a photographic view of the same.

PLAN No. 7.

(Built-up Area 2170 Sq. Ft.) (Cost Rs. 15400)

The plan illustrated in Figs. 91, 92 and 93 represents an attractive building suitable for middle class families of moderate means. Each floor contains a self-contained independent flat with two bed rooms. As the entrance to the staircase is provided both from the inside and outside, it very conveniently admits of either one, two or more floors being occupied by the same family. In that case the kitchen on the upper floors will serve as a third bedroom. All the rooms are of adequate and economical size for a middle class family. The central room opposite the kitchen might serve both as a dining room or a lobby giving independent access to

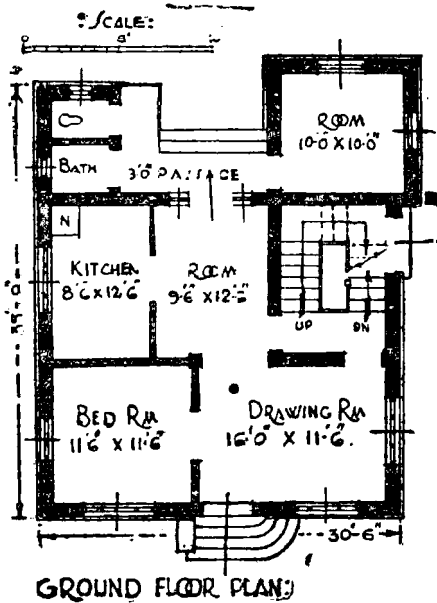
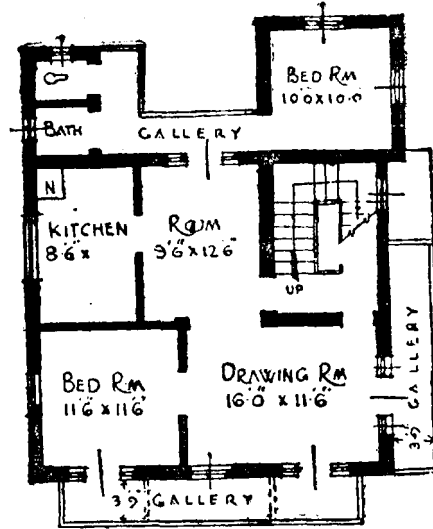

Fig. 91.

every room of the house. The staircase is four feet wide with an easy climb.

On the upper floors there are 3' 9" wide galleries on two sides which considerably enhance the conveniences.

All the outer walls are thick to bear the load of upper floors and to protect the house from the inclemency of weather and from thieves. The inner walls are 6 in. partitions with a central R. C. C. column to carry the ends of beams supporting upper floors.



FIRST & SECOND FLOOR PLAN:

Fig. 92.

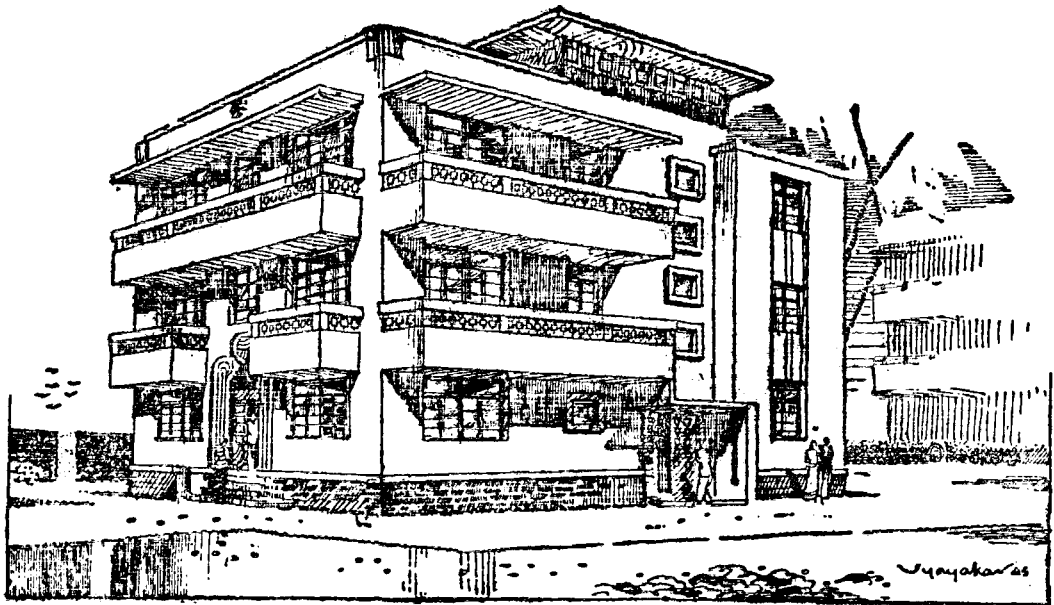

Fig. 93.

## PLAN No. 8

(Plinth Area 1410 Sq. Ft.) (Cost Rs. 11500)

This, very convenient, single storey cottage is designed specially for beauty and convenience, and provides all the elements of refinements and comfort for a cultured middle class family, having an artistic taste. The main entrance is from a small vestibule in the right hand corner, which leads directly either to the bedroom in the front, or the spacious drawing hall on the left. The special feature of the latter is the series of vertical windows, almost covering the entire front wall. There is a small, but cosy and attractive dining room on the left of the drawing-room forming a part of the latter, and very conveniently situated with regard to the kitchen. The bedrooms are small but possess the luxury of having an independent private bath room attached to each. The central verandah would serve as an excellent multi-purpose or utility room. The kitchen is good sized with a small store room on the rear side, and a verandah in the front, which provides also an exit from it. Thus the grouping of rooms is excellent and the house promises to be a real home, and leaves nothing to be desired.

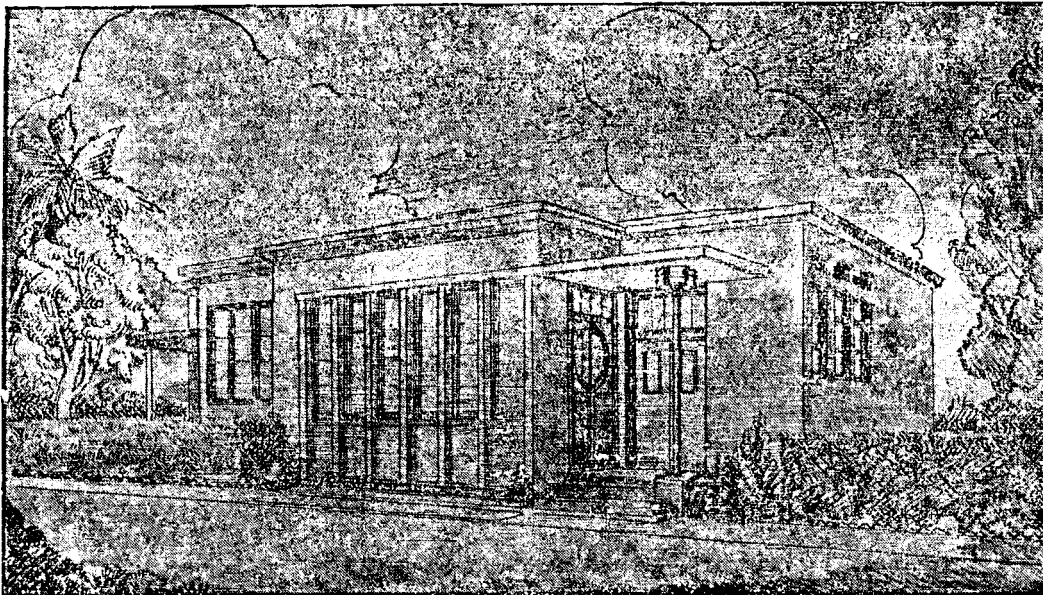
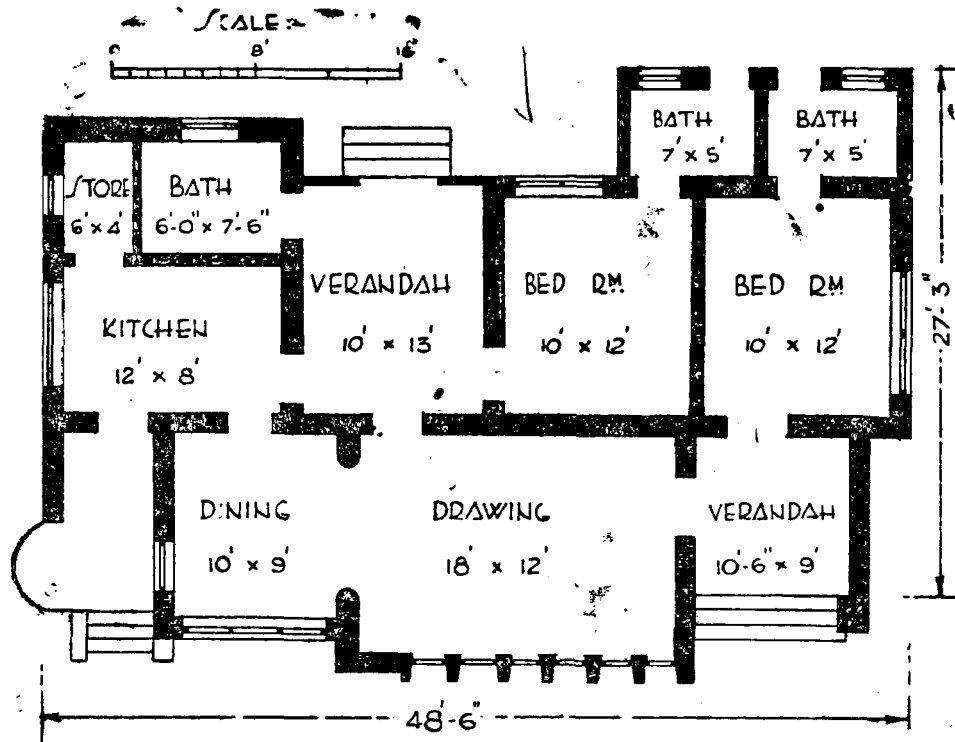

Fig. 94.



## : GROUND FLOOR PLAN :

Fig. 95. (Plan No. 8).

## PLAN No. 9

(Plinth Area 2230 Sq. Ft.) (Cost Rs. 13400)

Nestling low to the ground, this suburban cottage, with its rugged simplicity and an air of hospitality, combined with a feeling of comfort, is most inviting. The two bedrooms of spacious size, with dressing and bath attached to each, are placed in the direction of the breeze. Kitchen, fuel room, pantry and the dining room are grouped in another corner in a very convenient manner. There is a hatch in the pantry wall for serving meals in the dining room. The large drawing room and the spacious office are close to and independently approachable from the vestibule at the entrance. The staircase is located at a convenient place. The space below the latter makes the drawing-room still more spacious. A long verandah on the rear side allows an independent access to each and every room in the house. The staircase leads to the upper landing above the dining room, which together with the space for the pantry on the Ground Floor forms a pleasant bedroom with a gallery in front. Another large bedroom is provided on the top of the drawing hall and a flat terrace is made on the top of the bedroom on the left hand side and part of the office. The house would be more suitable for a North-facing.

The low sweeping roof lines seem to make the house grow out of the ground. The sense of shelter which is the primary purpose of every house is

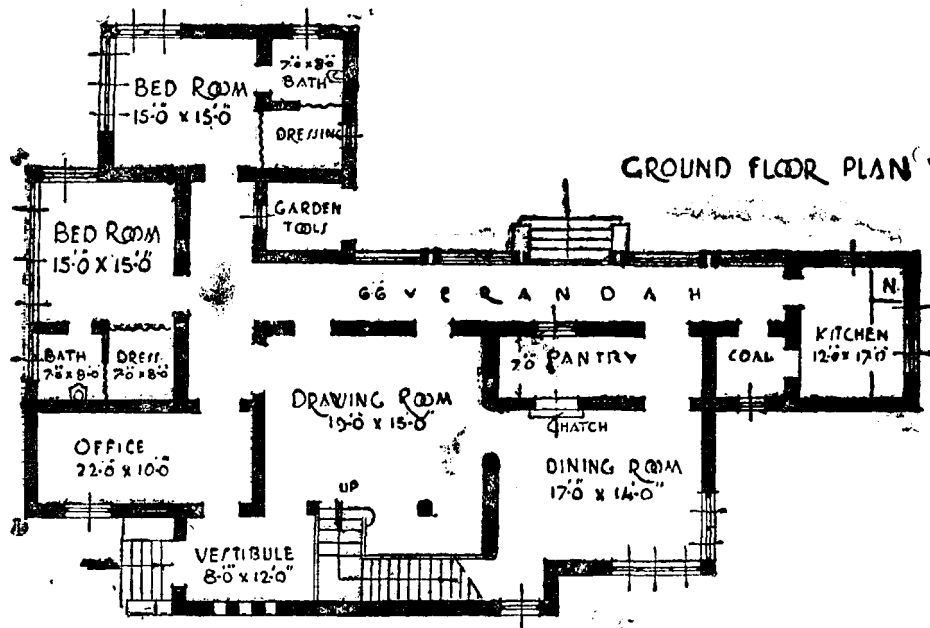

Fig. 96. (Plan No. 9)

obtained by the high and steep gable in the centre which extends over the entrance vestibule.

The steeply sloping high roof in the centre is the central feature which at once attracts the eye.

As the house is designed to be built in one of the economic ways with walls of earth, as previously suggested, all the walls including partitions are thick.

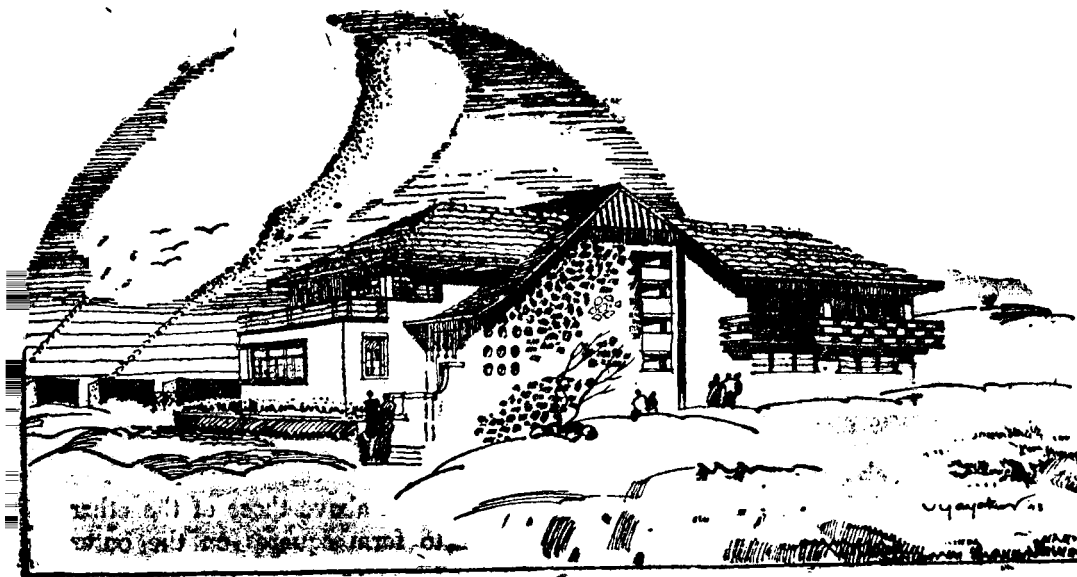

Fig. 97.

## PLAN No. 10

(Plinth Area 2220 Sq. Ft.) (Cost Rs. 23000)

This house is designed for a mofussil area, where space and also local building materials are available in plenty. That is why there are spacious verandahs on three sides, and a large passage area is spent in giving free access to rooms.

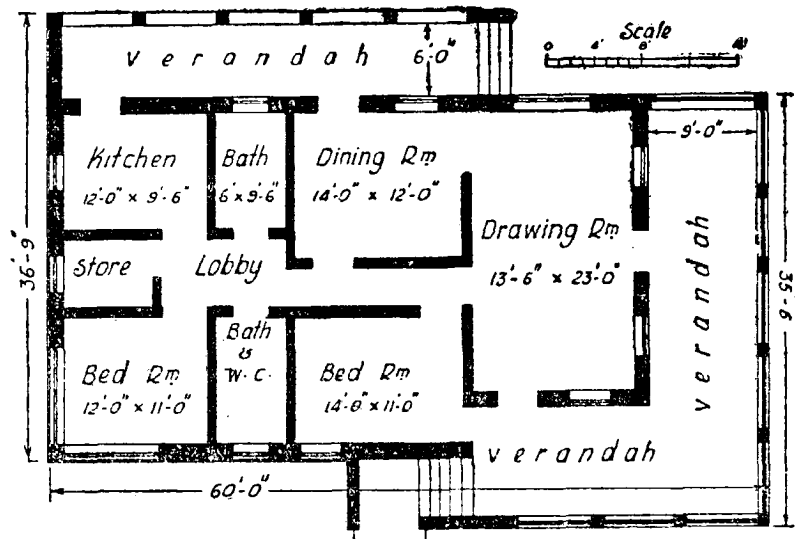

Fig. 98.

There are two entrances to the house, the main one being in the verandah in front of the drawing-room. This L-shaped verandah has made it possible to use the portion parallel to the length of the drawing room unobstructed for sitting purposes. In fact, it forms, as it were, an extension of the drawing room. The latter is a large room occupying almost the whole width of the house. Both the bed rooms, which are of good size, are placed in the direction of the breeze. There is a bath room between them for common use, in addition to the general bath room for the use of all. The kitchen, situated in a corner, is of sufficient size. Its position ensures the escape of the kitchen smells and smoke easily outside the house. The store room, though small, is very conveniently placed near the kitchen. The dining room should have been quite close to the kitchen, but is not far away. The verandah on the rear side, which covers the entire portion of the ladies' department, may be regarded as strictly allotted to the ladies, as the one in the front is allotted for gents' activities.

The elevation, though simple and unassuming is very attractive. The four walls of the drawing room are raised a few feet above those of the other rooms, and the simple lines drawn in plaster to form squares on the outer

surface at once catch the eye of the observer. The long continued horizontality of the verandah roof slab, with a number of rectangular columns supporting it, has combined with other features to make the composition harmonious and pleasing to the eye.

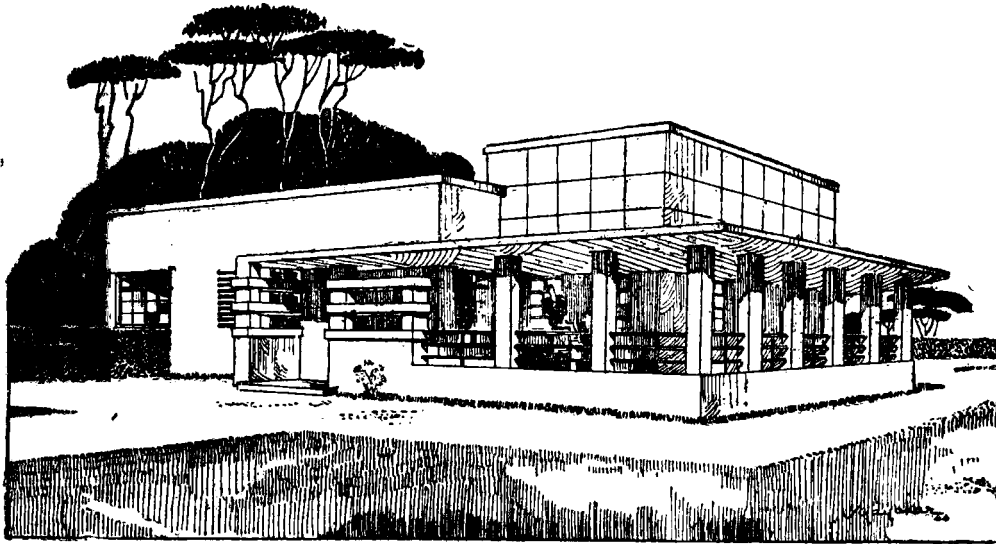

Fig. 99 (Plan No. 10)

### PLAN No. 11

(Built-up Area 3340 Sq. Ft.) (Cost Rs. 24400)

The house shown in Figs. 100, 101 and 102 has several novel features. Its planning is excellent and most suited to the modern way of living on the part of an upper middle class family.

The first thing which attracts the attention is the oval, open terrace in the front which is the connecting link between the inner apartments of the house and outside garden. The terrace being in front of the drawing-room, library and dining room, suggests any of three functions : It may be used for recreation, or reading or out-door dining. There is a large folding door from it to the library.

The main entrance is on the left hand corner into a vestibule, beyond which there is a small reception room. The room behind it may be used either as ladies' or a bedroom or a formal drawing-room. In the latter case the rest of the house can be treated as strictly private by providing across the passage just near the staircase landing. The drawing room and dining rooms have bay windows. Between the library and dining room there is a curtain of folding partition. In the front corner of the dining room there is space for a writing

H...11

table or a sewing machine just below the window. The kitchen is provided with modern equipment, and an exit door to the outside.

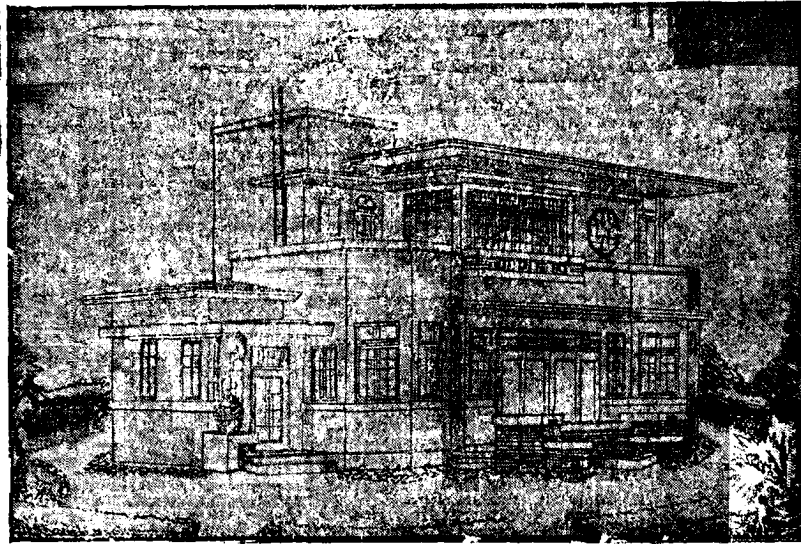

Fig. 100.

Upstairs, there are three good bedrooms each provided with a separate bath and its own terrace. Lot of closet space is shown in each bed room on the First Floor plan.

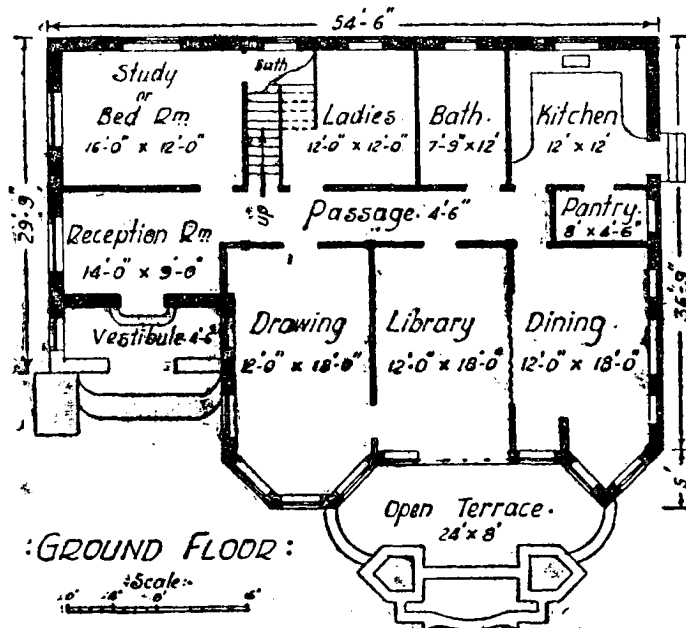
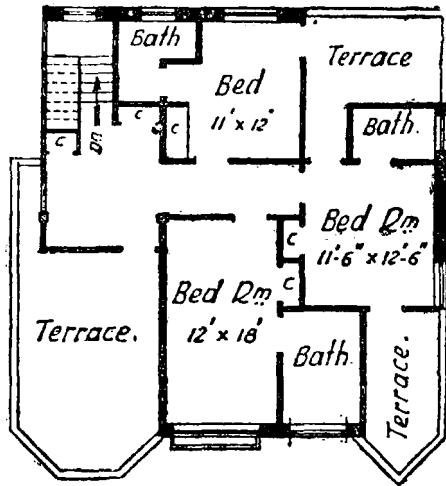

Fig. 101.



:FIRST FLOOR:

Fig. 102 (Plan No. 11)

The planning is made with a view to economy also in construction. The outer walls are thick enough for protection against heat and for bearing the load of the upper floor and roof, but all the inner walls are thin partitions and for supporting the load there are R. C. C. columns provided in them which are shown on the plan.

The exterior view is very pleasing. For reaching the top of roof slab for repairs, etc. a steel ladder is provided.

PLAN No. 12

(Built-up Area 1720 Sq. Ft.)

(Cost Rs. 27500)

This house is another example of compact, economical planning. The independence and privacy are best maintained without sacrificing much space in passages or lobbies.

The entrance is placed in one corner of the verandah to avoid waste of space in passage and to make the verandah more useful. The latter in front is spacious enough to meet all the normal needs of the family. Behind it, is the drawing-room of ample size for the type of the cottage. The staircase is placed at a very convenient location, so that it can be approached very easily from any room and also from the front. The space below the staircase is utilised as a store room. The dining room and

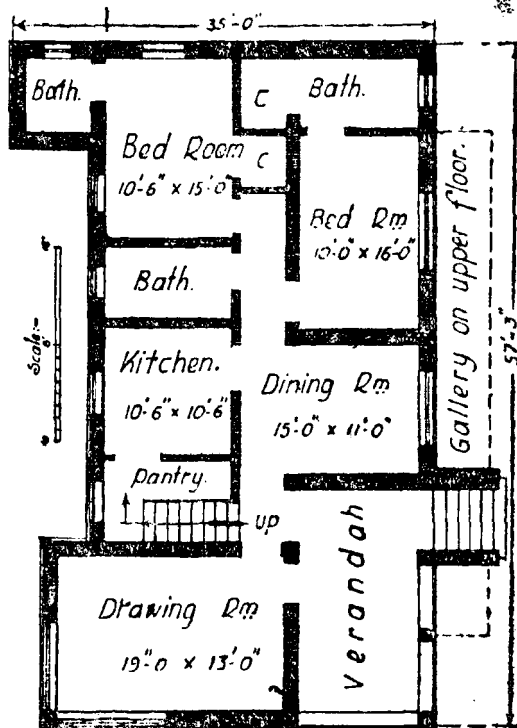

:GROUND FLOOR:

Fig. 103.

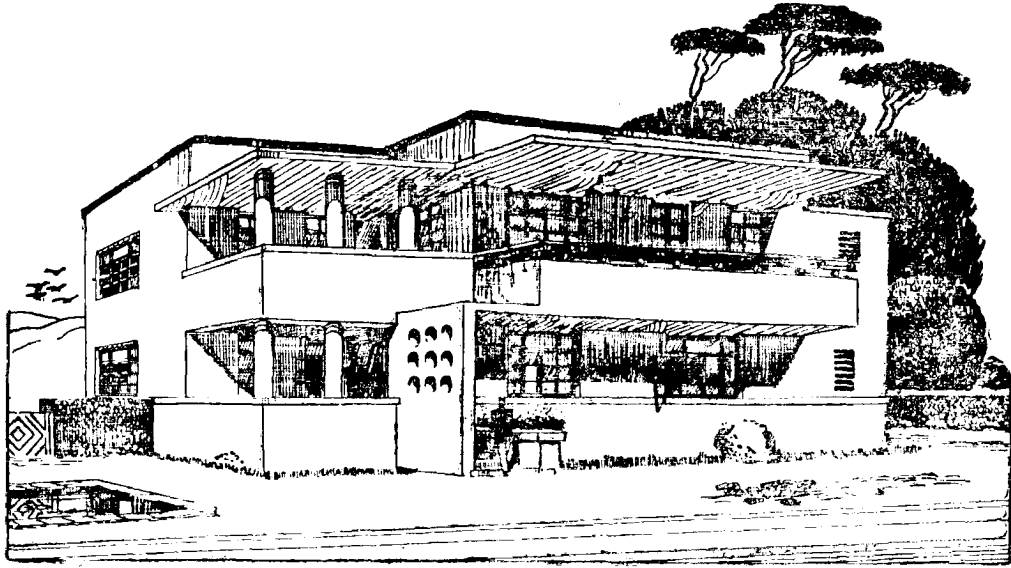

Fig. 104.

kitchen are opposite each other. There is no wall provided in the dining room opposite the kitchen, so that, even with small dimensions, it has become spacious. Adjoining the kitchen there is a general bath room of the family. There are two bed rooms on the rear side with their bath rooms. Large closet spaces are provided in both the bed rooms.

Every room is adequately lighted without a single nook or corner which is dark. Perhaps the only drawback of the plan is that no back entrance is provided. There is only one entrance to the house from the front. This can be remedied by providing a doorway in the kitchen in the corner next to the bath room.

Upstairs, there are five bed rooms, a verandah and a gallery. Thus within a small space, the house provides so much accommodation with seven bed rooms..

The comfortable arrangement inside is fully reflected in the exterior, which shows contentment and repose in every line.

## **More Practical Suggestions : XIX**

### **and**

## **Hints for Economy**

(1) Cutting up timber by departmental agency should not be attempted by laymen, as it is a risky business. The purchase of logs requires experience. Then, the sawing requires experience, care, and constant supervision. The waste timber obtained cannot be economically utilised on such a small building work in hand and thus forms a cumbersome heap which ultimately fetches no more than its fuel value. Besides, for want of getting scantlings of the proper size in time the progress of work may be hindered.

(2) When the work is small, and particularly of the nature of repairs, it is often cheaper and more convenient to use a mixture of 7 or even 8 parts of sand to 1 of cement instead of lime mortar.

(3) Even in places where excellent stone is available at a cheap rate, cut stone steps prove to be a very costly item. Unless finely dressed, they do not present a neat appearance, and dressing costs a good deal. Instead of this, if steps are roughly formed of lime concrete, brick or rubble masonry in lime, and flat flagstones with edges rounded in the front, are laid on their top, they are not only cheaper but also look clean and equally well, if not better.

(4) Verandahs and passages should, as far as possible, be paved with stone slabs, so also the door sills, if the floor is to be of *murum* or mud. These places are subject to considerable wear.

(5) The economical stock sizes of steel joists are 4 inches by 1½ inches or 4¾ inches by 1¾ inches and if one dimension of rooms is kept 12 to 13 feet, great economy is caused by their use for upper flooring. Similarly, the stock size of timber scantling is 6 feet length. If the sizes of windows and cupboards are limited to that length, considerable economy results.

(6) Except, perhaps, in the exposed situations, wood should not be painted, as the paint has to be renewed at frequent intervals at great cost, and if it is not done in time, it looks shabby. Instead of this, if it is coated with some cheap mixture, such as Solignum or Creosote or simple linseed oil and coal-tar boiled together and mixed in kerosene oil, to form a paint of dark colour, its appearance can be preserved for a long period very cheaply by occasionally wiping the surface with a rag dipped into kerosene oil.

(7) Painting and varnishing done in wet weather is useless. It should always be done in the hot weather.

(8) Lead paints are cheaper and better for iron work. Zinc paints are not spoiled by the action of smoke. At the most, washing the surface with a solution of washing soda gives it the appearance of freshness.\*

---

## **Check List of Questions : XX** **on Health & Safety**

Please see if you could answer these questions satisfactorily for the preservation of health and safety of your family.

- (1) What is the average number of persons per bedroom ?\*
- (2) Is there sufficient cross and through ventilation in the house, particularly in the bedrooms ? (Vide page 99).
- (3) Does sunlight enter every room of the house, particularly in kitchen and bedrooms in some part of the day or other ?
- (4) Is there any damp or mouldy odour anywhere in the house ? If so, have you taken immediate steps to find out the cause and remove it ?
- (5) If there be a basement floor or a cellar, are there facilities of draining it ?
- (6) In what condition is the privy ? Has it a water-tight floor and efficient provision for excluding flies ?
- (7) Is there any pool of stagnant water near the premises ? If so, have you closed it ? If it be not possible to do so, do you frequently put kerosene or crude oil so as to keep the surface of water always covered with its film ?
- (8) Do you, at frequent regular intervals, inspect the premises occupied and used by your servants, particularly the places where cooking utensils are burnished to see that they are at all times kept clean ?
- (9) Do you frequently inspect open drains to see that they are not choked ?

### **Food**

- (10) Is the floor of the kitchen made of some smooth and watertight material, such as cement concrete or polished slabs or tiles laid with joints in cement, so that any soft food spilled may be scrubbed and washed ?
- (11) Have you provided a bin in the kitchen, with a tight lid, for collecting garbage, food crumbs, etc., and are persons working in the kitchen trained to wrap garbage and waste food in paper before it is thrown into them,

---

\* The standard in England is 2.5 adults per bed-room, a child under ten being counted as half an adult.

so that it should not stick to the bottom and sides of the bin ? Is the bin regularly emptied at least twice a day, scrubbed and washed ?

(12) How is the garbage disposed of ? Is it thrown into municipal bin, or if there be no municipality, thrown into covered manure pit away from home, or better still, burnt in an incinerator or on open ground away from the house ?

(13) Are food-stuffs kept covered from dust and other sources of contamination ?

(14) Are fruits and perishable vegetables stored in well-ventilated cupboards provided with shutters of fine mesh wire gauze so as to exclude gnats and mosquitoes ?

(15) Are milk, curds, butter and other dairy products stored in portable cupboards of fine mesh wire gauze sides or in wall cupboards with fine wire gauze shutters and air bricks on the back ?

(16) Is the cook careful to wash his or her hands before starting work and frequently afterwards during the process of cooking ?

(17) Are persons handling food particular about body cleanliness and personal hygiene ?

(18) Do you see that no dirty dishes are allowed to stand in sinks and cupboards longer than absolutely necessary ?

(19) Are *chullas*, sinks, table tops, shelves and minor tools and equipment such as choppers, cutters, grinders, graters, egg-beaters, butter-churners, and the like washed thoroughly every time after their use ?

(20) Do you take care to wash green leafy vegetables in a solution of potassium permanganate before they are eaten as uncooked salads ?

#### Personal Hygiene

(21) Have all the members of the family including young children, been trained to brush and wash their teeth twice a day—first in the morning before any food or drink is taken and last at night before going to bed ?

(22) Have they all been trained to wash their hands before touching any food or other eatable things ?

(23) Are they using their individual towels and tooth brushes ?

(24) If an individual contracts eczema, itch, ring-worm or other communicable disease is he or she careful to use his or her individual soap, towel, *dhoties*, or *saries*, etc., and act in such a way as the disease would not spread to other members of the family ?

**Safety in Homes**

(25) Is the staircase of fire-proof material? If not, are there sufficient number of exits for fire-escapes provided on each floor and are they at all times, kept free of boxes and lumber?

(26) Do you periodically inspect the building and see that as a result of earth movements or uneven settlement of foundations, no wall or part of a wall is inclined out of the plumb line, also see that no timber used in the building, particularly in positions of posts, beams, rafters, etc., is attacked by white ants or dry rot?

(27) If there is piped gas supply for cooking and lighting, do you frequently make yourself sure that no pipe or equipment is leaking?

(28) Are poisons, loaded fire-arms and other dangerous materials safely stored so that there is no chance of any danger left from them? ✓

(29) If the home is wired for electricity, are fuses and other safety devices provided to eliminate fire accidents?

(30) Are the railings and parapet walls in galleries and roof terraces of sufficient height and of sufficiently small openings so that children may not easily climb over or fall through?

(31) Are precautions taken to make the water cisterns in garden inaccessible to young children playing round about? If they are low, are they covered with a grating of iron, to preclude children falling into them? ✓

## APPENDIX No. 1.

### A Note on Clays Impervious to Water.

There are four main types of soil which occupy the major part of India. They are :—(1) Alluvium, which covers an extensive area of the Indo-Gangetic plain in Northern India. (2) Black cotton soil or “Regur”. (3) The black or red soils overlying the metamorphic rocks of Madras, and (4) The laterite soils which occupy the coastal parts of the Sahyadri and occur also at many places in Southern and Central India and the Uttar Pradesh.

Between these there are innumerable minor varieties caused by local conditions. Thus, though alluvium is yellow loam, in many parts it is sandy or even clayey, the latter is generally pink and sometimes even bluish green in colour. The stickiness of the clayey soils is due to the high percentage of alumina and iron they contain, and the impermeability of the soils is due to the alkali bases present in them, especially in the form of sodium.

Generally speaking, all the varieties are alkaline in reaction. Exceptions to these may be found in certain small areas, where the rainfall is high and wind fierce. For instance, in Assam and in the Konkan of the Deccan the soil is distinctly acidic in character. The alkalinity is due to the presence of a strong alkali base, and a comparatively weak radical. The acid soils contain a high proportion of hydrogen ions, and the alkaline soils, that of hydroxyl ions. The bases in soils are either calcium, magnesium, potassium, or sodium. Of these calcium and magnesium bases tend to make the soil loose, and those of potassium and sodium, especially the latter, impervious.

The object in making the earth suitable for building purpose is just the opposite of what it is in making it fit for agriculture. For the latter we try to reduce alkalinity by mixing certain materials, whereas, for building purposes our aim is to render a neutral soil alkaline by adding certain suitable soils to it. Both these are rendered possible on account of a certain chemical affinity which exists between a soil and a salt solution, viz.

*When soils are brought in contact with solutions of salts, a chemical reaction takes place and the bases are mutually exchanged.*

This phenomenon is called the ‘Exchange of Bases’.

Thus it is possible to reduce a soil containing a preponderance of a certain base to another of any other base. For agricultural purposes, soils containing potassium or sodium bases, which make them stiff, are sought to be reduced to those of calcium base, as the latter makes them more or less loose and porous. On the other hand, the object to be aimed at, when rendering earth suitable for building purposes, is to displace other bases in a soil by sodium base so as to make it impervious to water, or to “sodiumise” it, to speak in technical terms.

It is evident that it is comparatively easy to sodiumise a soil which is agriculturally poor, for it already contains some sodium salts. In order to understand the exact chemical action involved, suppose we have got handy and in abundance a soil containing calcium as the base. When we treat a sample of this soil with solution of common salt (which contains sodium) what happens is this :—

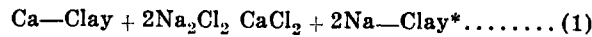

We get calcium chloride and sodium clay. Instead of treating the soil with solution of common salt (sodium chloride), suppose we do so with sodium sulphate ( $\text{Na}_2\text{SO}_4$ ), still the same result is obtained as far as sodium and calcium clays are concerned :—

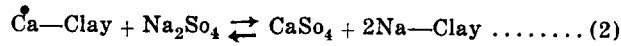

Sodium clay is produced again. That is, the original calcium base of the soil is turned into sodium base.

Now sodium clay, in presence of water hydrolyses, producing hydroxyl ions of sodium (NaOH) which cause alkalinity. The chemical equation for this is :—

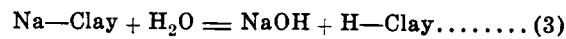

Even a trace of NaOH tends to render the soil impervious to water. The sodium clay formed has its particles highly dispersed; they remain for a long time in suspension in water, and thus make the soil sticky and impervious. This is entirely due to the high electrokinetic potential of Na-Clay which is  $1\frac{1}{2}$  times that for the calcium clay.

The free sodium hydroxide (NaOH) renders the soil impervious to water and, under suitable circumstances, it further reacts on the aluminium hydroxide, if present, and forms sodium aluminate. When this happens, the aluminium hydroxide precipitates in a gelatinous condition and further helps to make the soil impervious to water.

Thus, when salts of sodium are mixed with any soil, and water is added to it, in course of time NaOH (sodium hydroxide) is formed, which is responsible for causing the imperviousness.

The soil inside and in the neighbourhood of village sites contains a lot of sodium salts, but it also contains potassium salts in the form of nitre ( $\text{KNO}_3$ ) as a result of accumulation on it of nitrogenous matter such as urine, excreta, etc., for a number of years. In fact, this nitre lends the white colour to it. When this 'white earth' comes in contact with rain-water, for instance, on the top of mud roofs, the potassium salts are leached out especially from the surface, and the latter soon automatically becomes impervious and prevents penetration of water. The same thing happens when water is mixed with such white earth, that is, most of the potassium salts are leached out and the sodium salts which remain in preponderance impart impermeability to it.

One often sees that this white earth or *Khari Mitti* used for roofing or other purposes deteriorates in course of time. The reason is that rain water, particularly in the beginning of monsoon, is charged with carbon-dioxide from the atmosphere dissolved in it. When white earth in position such as that on the top of mud roofs is long exposed to such rain, the  $\text{CO}_2$  dissolved in the rain-water forms with the Na-salts in the earth sodium-bicarbonate ( $\text{NaHCO}_3$ ) by the reaction :—



---

\* This as well as the next equation are not strictly correct. The valency of clay is not definitely fixed. Besides, this is not a definite chemical change but a physico-chemical one.

When this takes place Na is easily removed from the soil in the form of bicarbonate of soda, and the alkalinity and with it the imperviousness begin to disappear because the process of hydrolysis is suppressed and free alkali is no more produced. In such circumstances, in order to render the roofing earth again impervious, the remedy is to mix fresh sodium salts with it and leach them out. It has been observed after experiments that when the concentration of Na-salts is 0.6 p.c. optimum impermeability to water is obtained. Further concentration than this tends to prevent hydrolysis of Na—Clay and reduce its impermeability.

## APPENDIX 2

### Duties of a House-Holder for Preventing or Fighting an Epidemic

If in the centres called "Home" the foundations of health are laid, the task of Government and Local Bodies would at once be simplified. "If the houses are taken care of", says the Sanitarian, "the towns will take care of themselves". If this were to take place, there would be no necessity of legislative acts in respect of sanitation to be enforced. But unfortunately in India, the ignorance even of the fundamental principles of hygiene, coupled with prejudices, peculiar religious and social customs, and domestic habits, so ingrained in the course of ages, as to become innate and form an integral part of the life of the individual and the community to which he belongs, come in the way and cause him to offer a passive resistance to any sanitary measure. What is required is the establishment of sanitary associations in every village and town to make co-ordinated strenuous efforts, (in co-operation with the Local Bodies), by every possible means to impress on the people the necessity of observing sanitary precautions with the ultimate object of gradually creating a desire on their part for healthier surroundings. The sense of responsibility must be developed; the inspiration must come from within. Then and then only would it be easy to keep under control or altogether stamp out any infectious disease before it gets time and opportunity to spread out in an epidemic form.

In order to be able to do this efficiently, one must understand intelligently how such infectious diseases are caused and spread, how they should be recognised, and what precautions must be taken and what dangers must be guarded against, to prevent their extension to the other members of the family and the community at large. With this object in view it is proposed to give a few brief notes on the principal diseases communicable from man to man.

#### Cholera

**Symptoms** :—Profuse purging and vomiting of an almost colourless slightly whitish watery material; muscular cramps, especially in legs; suppression of urine; hollow sunken eyes; anxious look, and collapse. The onset of disease is sudden, and the symptoms very severe, from which the disease can at once be recognised. Time is an important factor in saving a life, and the prompt recognition of the symptoms is therefore extremely important.

**Origin** :—The poison consists of very very minute living organisms which enter the intestines and multiply there. A person can be attacked by cholera *only if he swallows these organisms* either with food or drink.

**Mode of Spread** :—(a) Water in a river, tank, or well is infected by washing of anything such as hands, clothes, utensils, etc., infected by the living organisms.

(b) Food, including milk, is infected by flies sitting on it, after they have settled previously on discharges of a cholera-infected person, or by the handling of it by hands or in utensils soiled by such discharges even in microscopically small quantities.

**Prevention :—Personal Prophylaxis :—**Never drink water which is not previously boiled or sterilised in any other way. Observe this strictly even in the use of water for washing vessels and washing vegetables to be used in an uncooked state.

Avoid foods that may cause indigestion. Do not use stale food which is likely to be in a state of decomposition. Food-stuffs in a hot state are least likely to be contaminated by flies.

Avoid too much fruit when an epidemic is likely to break out, avoid especially both unripe and over-ripe fruit, avoid *shirbets* of all descriptions. The digestive juice of a healthy stomach is slightly acidic which destroys the germs of cholera. Eating too much fruit or unripe or over-ripe ones tends to make it alkaline and to destroy this resisting power.

Avoid even aerated waters unless they are carefully prepared at home. Soda water, unless allowed to stand for 3-4 days after it is manufactured, does not destroy germs of cholera, and it is doubtful if it does so even afterwards.

Avoid purgatives particularly salines. The fact that a purgative was taken easily makes the symptoms of cholera, and the doctor may be easily deceived and valuable time lost for administering prompt treatment. Such cases are by no means uncommon and hence this emphasis.

Keep the surroundings scrupulously clean.

Get yourself and all the members of your family inoculated with cholera vaccine, or take anti-cholera Bilevaccine pills and 2 or 3 drops (only 2 or 3 and no more) of camphor oil to obtain immunity.

If there is a well in the compound of the house for supplying drinking water, sterilise its water in some suitable way.

Notify at the earliest opportunity to the Local Authority and isolate the patient even if it be in a separate room of the same house.

Disinfect everything connected with the patient, including discharges, clothing, utensils, such as plates, cups, etc.

Let only one person attend on the patient at a time and he or she must wash his or her hands with carbolic soap before touching anything outside the patient's room.

As soon as an attack is suspected, get a doctor to treat the patient **AT ONCE**. Time is very valuable.

### Plague

**Symptoms :—**Slight shivering, strong headache and restlessness followed by a sudden advent of fever; blood-shot eyes, vacant look; the patient walks and talks like a drunken man.

In the pneumonic variety, the lungs are seriously affected and there is no glandular swelling. This variety, though rare, proves generally fatal. In the bubonic plague the glands or buboes appear in 1 to 5 days and are very painful.

**Origin and Mode of Spread :—**The following are some of the important conclusions of the Plague Commission :—

- (1) Bubonic plague in man is entirely dependent on the rat.
- (2) Pneumonic plague is highly infectious. It is, however, rare (3 p.c. of all the cases).
- (3) Infection is conveyed from rat to rat, and from rat to man *solely* by means of the rat-flea.
- (4) A case of bubonic plague in man is not in itself infectious.

The fleas attack rats first, but when they are deprived of their food by the death of rats they attack man. For this reason, one generally hears that rats die first of plague, and after an interval man is attacked.

**Prevention :—**Prevention and destruction of rats is therefore the only effective remedy. The measures to be adopted must be all directed towards this. They are :—

- (a) The building should be rat-proof and rat-free.
- (b) Relieve over-crowding not only of man but also of lumber, which favours the harbouring of rats.
- (c) Destroy the rats either by poisoning or better still, by trapping.
- (d) Disinfect the house by means of kerosene emulsion (see page 138 which is an excellent flea-destroyer).
- (e) Keep the house and premises clean. Accumulation of rubbish provides food and shelter for rats.
- (f) Get yourself and every member of your family inoculated with plague vaccine or take anti-plague Bilevaccine pills.

#### Enteric Fever or Typhoid

**Symptoms:** This is rather a difficult disease to diagnose, even for a medical man, in the beginning. In a typical case the temperature during the first week is continuous and gradually rises to the maximum (103° to 105°F) with diurnal remissions. During the second week it remains continuously high with slight diurnal remissions. During the third week the remissions are more marked. In the fourth week, first the morning and then the evening temperature becomes normal. Convalescence is said to be established when the evening temperature is normal for two successive days.

Some diarrhoea is usually present with distension of stomach from the second week, and the stools are yellowish green. The tongue is coated and the eyes are bright and lustrous.

**Origin :—**The disease is caused by specific micro-organisms which infect intestines, where they multiply and pass through the excreta and urine.

**Mode of Infection :—**The most common sources are (a) water, (b) milk and food, and (c) flies and dust. The drinking-water supply is often contaminated by sewage, sometimes the excremental matter of a typhoid patient finds its way to wells, tanks, and rivers either directly or indirectly through soiled linen, vessels, etc., washed in or near them. Milk is infected by flies alternately sitting on them and on the discharges of typhoid patients. It is also spread by flies and dust settling on slices of melons, *papais*, etc., or sweets exposed to air. The last one is common near schools, bazaars, railway platforms, etc.

**Preventive Measures :—**(1) Boiling of all water used directly for drinking or indirectly for buttermilk, rinsing utensils, and washing vegetables to be used uncooked. (2) Avoiding bazaar-made sweets and cut slices of fruit. This must be enforced in the case of school children during recess hours in particular. (3) Ino-

culation with anti-typhoid serum or the use of Bilevaccine pills, which give immunity for a year. (4) Disinfection of all clothing and articles used by the sick. (5) Disinfection of all discharges of the invalid. They should be first mixed with a disinfectant and then buried on an open ground under at least six inches of dry earth. The discharges of the patient even in the convalescent state contain germs of typhoid. (6) The attendant must keep his or her hands scrupulously clean, especially before taking or serving food, milk, etc.

### Small Pox

**Symptoms:** A sudden onset of high fever with severe headache and a severe pain in the back and a flushed face. With characteristic eruption, which appears on the third day, first on the face and the wrists, the fever goes down. It is distinguished from measles by the absence of the catarrh of the nose, eyes, and lungs, which is very marked in measles. In the latter, again, the rash appears on the fourth day and with it the temperature rises.

It is one of the most contagious diseases. The range of infection is the greatest when the scales or scabs begin to fall off, and are carried by wind and flies, etc.

**Preventive Measures:**—(1) Vaccination with a fresh serum, and revaccination afterwards every seventh year. (2) Rigid isolation of the patient. (3) Thorough disinfection of all discharges even of those from the nose and the mouth. Their collection on a piece of cloth and the burning of the latter is the best way. (4) Anointing the patient with carbolised oil and giving him after recovery one or two hot baths, with the whole body scrubbed well with carbolic soap before he is allowed to mix with other people.

### Malaria

This disease is too well known to need any description. It is essentially a disease of the middle and poor classes; because the latter do not get nourishing food, nor warm clothing and mosquito nets, nor do they afford to undergo the necessary prolonged treatment with rest, which the disease demands. On account of its very common prevalence, particularly amongst the poor population of the rural districts, it does not attract so much attention and cause a sensation as do the other spectacularly prominent diseases like cholera and plague, but when its far-reaching evil effects are considered, it is no exaggeration to say that it is by far the greatest destroyer of the human race.

It saps the vigour, lowers the vitality and makes the community unfit for the battle of life. It not only increases the death rate, but it also lowers the birth rate. It disorganises labour and seriously interferes with agriculture and commerce. It is estimated that it is responsible for over one million deaths per annum in India.

**Symptoms:** There is invariably an attack of shivering followed by fever. If the latter be high, there is a strong head-ache. The fever lasts for a few hours or sometimes even a day or two and it subsides with profuse perspiration. The subsequent attacks may come daily, on alternate days, every third or fourth day, or irregularly at intervals. In course of time the spleen is enlarged, digestion is impaired, and the person affected loses power of resistance to diseases and falls an easy prey to them.

**Origin:**—The disease is caused by particular germs which live on blood and multiply in it. They are sucked by the mosquito with the blood of the affected person and when it bites another person in turn, the germs are injected into the blood of the latter. Thus the disease goes on spreading from man to man solely through the agency of the mosquito.

There are two varieties of mosquitoes. (1) Culex and (2) Anopheles. The former may disturb one's sleep, but is harmless as far as the propagation of the malarial fever is concerned. It is the latter which carries germs of Malaria. The process of breeding of both the varieties is the same, viz. the eggs are laid in a warm place on, or mostly near, the surface of water; in two or more days they are hatched and the larvæ come out. The latter dive in water feeding on other insects in the water. They come to surface for breathing air. After a week the larva becomes pupa which mostly remains on the surface. After two or more days the skin of the pupa cracks and the adult mosquito emerges. The male feeds on plant and fruit juice but the female sucks blood of some animals, including man, and goes to a water surface only for the purpose of laying eggs once in three or four days.



Fig. 105  
Anopheles.

**Prevention :—**There are three ways of prevention. (1) Preventing mosquito breeding. (2) Destroying mosquitoes. (3) Protecting oneself from their attack.

The first is by far the most efficient. In order that the effort may be directed in the proper way in destroying the malaria-carrying mosquitoes, namely, Anopheles, without wasting it in killing the harmless ones viz. the Culex, it is necessary to distinguish between the two varieties correctly. The following are the features which distinguish them.

#### ANOPHELES

- (1) Wings spotted black and white.
- (2) The anopheles sits straight, making a definite angle with the wall surface as shown in Fig. 105.
- (3) The larvæ of the anopheles float immediately below water surface in a position parallel to it, as shown in Fig. 107.
- (4) When moving from its place the anopheles larva darts suddenly with a jerk.
- (5) The anopheles lives only in clear water and moves out and bites mostly by night.

#### CULEX



Fig. 106  
Culex

- (1) Wings not spotted.
- (2) The culex sits in a hunch-backed position with the head and tail thrown down and back raised as shown in Fig. 106.
- (3) The larvæ of the culex float much below the surface with the head hanging down as shown in Fig. 108.
- (4) The larva of the culex propels slowly.
- (5) The culex lives in dirty water and bites at any time.

Some of the habits of the anopheles shown above give clues for applying remedies for preventing their breeding. Some of the practical methods are given below :—

The main principle to be observed is that in no event is water to be allowed to stagnate near the house; for this, small

ponds and pools which are capable of being drained should be drained, and those which are not, should be either filled in with earth or suitably treated so as to prevent the breeding of mosquitoes.

*Kundies* or small cisterns for slop, or household water should be emptied regularly. Water from bath-rooms, etc., should not be allowed to stagnate on any account, or even to soak into the ground close to the house.

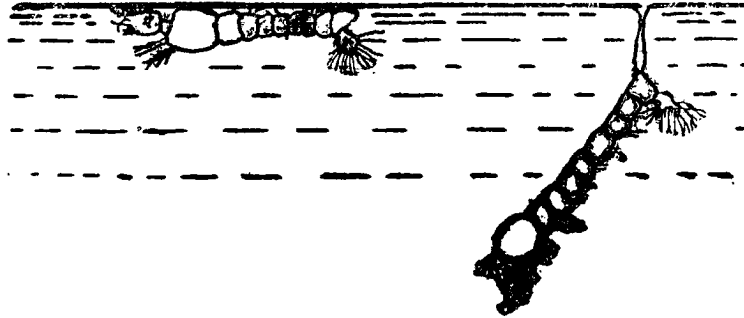

Fig. 107

Fig. 108

Weeds from *nallas* having sluggish flow should be removed from time to time as mosquitoes find in them an ideal place for laying eggs upon.

Water troughs for cattle should be emptied and cleaned regularly. Obstructions, if any, should be removed from surface drains and they should be scrubbed occasionally with a stiff coconut broom. The eaves gutters should be similarly treated in the wet season.

Hollows in trees should be filled with lime or cement concrete. Old iron tanks, cisterns, tin-pots, broken earthen pots, etc., thrown outside, in which water is likely to accumulate, should be destroyed.

Wells in use should be kept clean of any rubbish accumulating on the surface or in hollows and recesses in the sides; as the water is likely to be constantly stirred up while being drawn, mosquitoes will not breed on the surface of wells with clear water.

Unused wells should either be filled up or efficiently closed. No rubbish should be allowed to accumulate in the corners and lanes or narrow gullies between houses as they are bound to retain rain-water and form breeding places.

Aroido and other aquatic plants should not be allowed to be planted near the house.

Waste motor lubricating oils, which are otherwise useless, should be poured on the surface of ponds and wells not in use. This oil spreads on the surface in a thin film which prevents the larvæ of the mosquito from getting their air supply and in consequence of this, they die. The same purpose is served by kerosene oil but it soon disappears by evaporation and has to be renewed every third or fourth day.

**Protection from the Attack :—** (a) Using mosquito nets during nights affords considerable protection, but in the first place, it is not within the reach of the poor, and secondly, for efficient protection, not only should the nets have no holes in them, but there should be no opening or door flap in them for entering in. They should be let down in position before dark and should be carefully examined for any stray mosquito that may have intruded inside before going to bed.

(b) Regular use of quinine is another remedy. But this is impracticable, because it entails expense which is often beyond the means of the very poor people though the Public Health Department have made arrangements to supply it in Post Offices for a trifling cost. Again, it does not agree with the health of many. It is, however, useful both as a preventive and a curative remedy. In malarial districts even occasional use of it may help in checking the predisposition to malaria.

### Tuberculosis and White Plague

Tuberculosis is a chronic wasting disease caused by the bacillus called 'Tubercle'. The principal form in which it appears is the pulmonary phthisis, or consumption, in which the lungs are affected. But there are different varieties of tuberculosis each differently named according to the different parts of the body it affects. Thus, if glands are affected it is called 'Scrofula'; if the spinal chord is affected it is called 'Meningitis', and so on. There may be in the same way intestinal tuberculosis, bone or joint tuberculosis, or even skin tuberculosis all caused by the same germ the tubercular bacillus (T.B.). Even lower animals with the exception of the goat are not free from this disease.

**Causes :—** Extreme poverty, ignorance and some peculiar social habits are responsible for the spread of tubercular infection, which has been distinctly on the increase during the last decade as revealed by the last Census Report. Over-crowding and want of nourishment are the direct results of poverty. Over-crowding compels the members of the family to occupy the same room as the one occupied by the consumptive patient. The already inadequate ventilation becomes still less, and the risks of catching infection on the part of the healthy members of the family, increase. The evil is still greater in Northern India and other parts where the extreme cold requires the windows to be shut up during the night time.

The *purdah* system prevalent in most Mohammedan and a few Hindu communities further increases the incidence of deaths by the disease amongst women and children of these communities. The women-folk have to shut themselves up in ill-ventilated, dark rooms on the rear side, which is generally insanitary. Then again, mostly on account of poverty and partly on account of ignorance, the necessary precautions are not taken in the case of the females during and after confinement, particularly in respect of proper medical advice and nourishing food, and as a result, the incidence of deaths amongst females on account of this disease has, of late years, been very large. There is another reason viz., amongst the middle classes of today on account of unemployment and similar other reasons, purely economic, the age limit of the bridegrooms has increased in undue proportion to that of the brides. This naturally tells upon the health of the latter and creates a predisposition to this disease. At any rate the annual death rate on account of this disease in India is most appalling as compared with the most backward nations in the world. Hence, every effort must be made to educate the public mind in respect of the precautionary measures to be adopted.

**Symptoms :—** The individual affected looks anæmic and pale and lacks vigour. There is a gradual emaciation with decrease in weight and a rise in temperature during night. There are discharges from the parts affected, for instance, purging in the case of intestinal affection, expectoration, in that of the lung affection and so on.

**Mode of Infection :—** The germs are passed through the discharges from the affected part. Thus the sputum of the patient of pulmonary phthisis, and bowel discharges of the intestinal affection contain millions of T.B. These germs die out soon when exposed to fresh air and sun's rays, but they remain active and full of vigour for a long time, in stuffy, dark and damp places. Thus the sputum in a dark

corner may have dried up, and still may contain thousands of germs in a virulent state for months together. The dust exposed to sun and open air rarely contains living germs, yet what settles in dark corners and recesses must contain a large number of them. Flies settle on the discharges of the affected person and transmit the germs to articles of food. Even crows and other animals eating sputum in streets, after picking it up fly to a vessel of milk or water and dip their beak into them full of germs, and so on. There are innumerable sources and ways of infection, but by far the most fertile is the sputum. A consumptive patient in open air where the germs are readily attenuated by breeze, is not so dangerous as the one who shuts himself up by closing windows for fear of draught.

**Preventive Measures :—** All the preventive measures must be based on two facts known from the life-history of the germs, viz. (1) that fresh air and sunlight are detrimental to the growth of the T.B. and (2) that the disease is disseminated from an affected person to an unaffected one by actual transmission of the T.B.

For personal prophylaxis strictly observe the ordinary rules of personal hygiene viz. (1) Sleep with windows open. If draught is apprehended arrange a screen to break its force. (2) Take plenty of open air exercise and (3) Take sufficient nourishment in the food. Besides this observe the following 'Don'ts' :—

- (a) Don't occupy the same bed with a consumptive patient.
- (b) Don't occupy the same room with a consumptive patient unless there is a strong current of air coming inside.
- (c) Don't partake of the milk or food remaining after feeding him ; don't use his utensils such as cups, glasses, plates, etc., before they are sterilised. It is highly advisable that the patient should have a separate set of utensils for his own use.
- (d) Don't spit at all. The habit of spitting is very bad. Even an apparently healthy man may be passing T.B. (tubercular bacilli) in his spit or other discharges for years together before he is aware that he has been doing so. The best policy to be observed even on the part of a healthy person is not to spit at all, except into receptacles which can be washed in the ordinary course of household cleaning.
- (e) Don't eat sweets, slices of cut fruit, pastry, etc., exposed to air and dust of the streets and to flies.
- (f) Don't cough, or sneeze into another man's face ; always hold a handkerchief against the mouth or nose and turn your face aside.
- (g) Don't kiss in the lips.
- (h) Don't blow with your mouth on the surface of milk to keep back cream. Don't blow on hot tea or hot food meant to feed another person in order to cool it.
- (i) Don't drop a particle of food or sweets on the floor, and if you happen to drop it don't pick it up and use it.
- (j) Don't drink water or any other beverage from the glass used by others before it is thoroughly cleansed with water. The usual way of cleaning such glasses viz., rinsing the bottom and leaving part actually held in the lips untouched is useless.
- (k) Don't use ends of garments or the cloth you are wearing for wiping the mouth or hands, either of yourself or of those of others.
- (l) Don't allow dogs or cats to contaminate your food or milk.
- (m) Don't use road scrapings or dirty earth for scouring or brushing utensils. Use only ashes from the *chulla* or earth specially brought from field.
- (n) Don't forget to wash your hands with soap, once you have entered the patient's room and touched anything there, before you touch anything outside.

**Measures to be Adopted by the Consumptive Patient:—** These are necessary not only for safeguarding the health of those dear ones who attend on and who come in contact with the patient, but even to a greater extent in the interest of the patient himself to avoid the risks of fresh infection from his own sputum etc., which is bound to retard or even prevent his recovery.

Tuberculosis is a lingering disease and in most cases the purse of a middle class family is overtaxed, often causing it to run into debts. Hence, for their benefit only very cheap but efficient and practical methods have been suggested below:—

(1) The expectoration when indoors should be received into paper bags, and the latter should be burnt on fire afterwards. It would do if it is received into a glass or china receptacle containing ashes, provided it is emptied into an open pit and covered with at least 4 inches of dry earth, or the contents thoroughly burnt on fire, but the former method is simple and more efficient.

(2) The expectoration out of doors should be received into a kerchief of tough paper (sold cheaply in the market) and the latter should be burnt on fire afterwards as above; or into a large-mouthed bottle with a close-fitting stopper which should be emptied as above and washed 2 to 3 times with boiling water.

(3) If an ordinary handkerchief is used both indoor and outdoor, it should be kept immersed in boiling water for five minutes *before it gets dry*, and then washed with ordinary soap. If it is allowed to dry, even a slight shaking causes the dry particles of the expectoration to fall off and spread with the wind; and as the latter contains millions of germs there is every risk of the infection spreading to others who get that air into their lungs.

(4) The individual should scrupulously avoid sharing a bed or food with another person. Very often, others do not keep themselves aloof in this way for fear of offending the invalid or to smother his feelings arising out of segregation or boycott. If she be a mother of a young baby she should stop feeding her on the breast in the interest of both.

(5) It is generally not possible for a middle class family to allot an independent room to the tubercular patient particularly in urban area. The member of the family who will attend on the patient (and only one in perfect health should do it) need not be afraid of occupying the same room provided the room has a sufficient cross ventilation i. e. there are large windows in the walls on the opposite sides, and that they are kept open during night. If the patient is covered with warm clothing, draught need not be feared unless the health is very delicate. In the latter event a screen should be arranged some distance away from the window on the inner side to break the force of the draught.

(6) The patient's clothing, cups and other utensils etc., should not be mixed up with those in household use before they are kept immersed in boiling water or are thoroughly exposed to direct sun's rays for several hours every day.

(7) No opportunity of admitting sun's rays—no matter if it be possible only in a corner of the patient's room—should be lost. As far as possible the patient should spend most of his time out of doors under the shade of a tree etc. or at least in an open verandah.

(8) The bedroom should be cleaned with a wet broom dipped into a disinfectant, or if the floor be of concrete or paved with stone slabs, it should be wiped with a cloth dipped in a disinfectant. In no event should it be swept dry, as the germs in the particles of sputum etc. are likely to be beaten up in the atmosphere of the room and spread.

## APPENDIX No. 3.

## A Note on Preparing Door and Window Frames of Reinforced Concrete.

Wooden frames of doors and windows, as they have necessarily to be partially embedded into wall, are subject to the danger of being attacked by white ants and dry rot, particularly when the walls are built either wholly or partially in mud. Again, they are susceptible to being destroyed by fire, if any breaks out. Under these circumstances, reinforced cement concrete frames prove to be ideal ones. In some stone districts in India frames for doors consisting of two vertical side pieces and a horizontal lintel above them, all of finely dressed stone 7 to 9 inches square in section, are being used from very old times; but as the shutters cannot be hung on to the stone frames by hinges they are provided with tenons at ends which move in holes in the stone sill at bottom and the lintel at top for opening or closing the door. Another disadvantage of stone door frames is that as sufficiently long stones for the sides cannot be had at a cheap cost the height of the frames has in most cases to be restricted to from 5 to 5½ feet, causing great inconvenience.

Not only can all these defects be overcome by using R. C. C. frames but the latter can be prepared at less than half the cost of the teak wood frames. The process is so simple that any layman can prepare them at home.

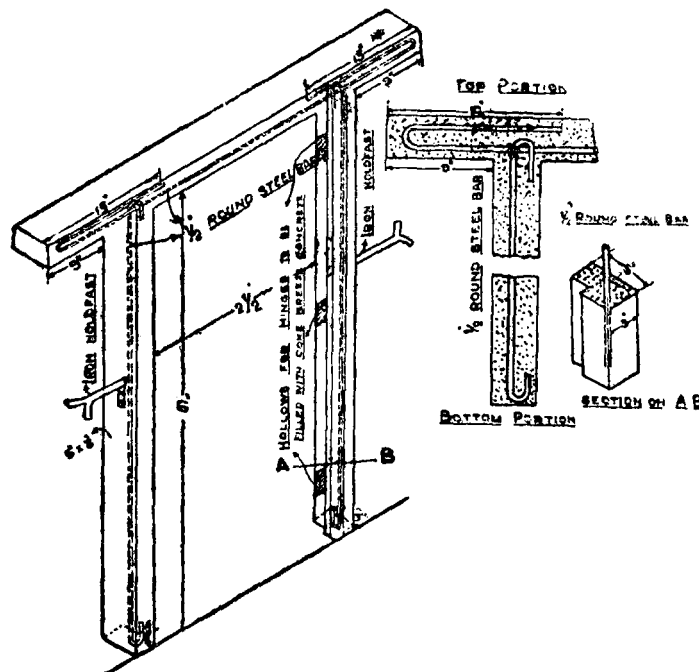

Figs. 109, 110 &amp; 111.

It would be convenient if all the doors were made of one standard size, say, 2½ feet by 6 feet so that one strong mould prepared of stout boards 1½ inches thick would serve the purpose. It is economical in the long run if careful attention is given for preparing the mould, which should be of only well seasoned teak or sal wood.

Figs. 109, 110, and 111 show an isometric view of such a frame just removed from a mould. It is 5 inches by 3 inches in section. Any village carpenter should

be able to prepare such a mould as to enclose a space of the section shown in Fig. 111. The surface on the inside should be smooth.

The reinforcement consists of mild steel round bars,  $\frac{3}{8}$  inch in diameter, with hooks formed at ends as shown in Figs. 109 and 110. It is necessary that the hooks at the ends of the top member should be 15 inches long. The two side pieces should be laid flat on ground parallel to each other at the requisite distance apart and the top piece should be inserted into the hooks and bound to them by means of a thin steel wire.

The mould should be placed flat on the ground and crude oil should be smeared with a rag on the inner surface. Then the inverted U of steel bars prepared as above should be laid inside it, resting at bottom temporarily on something so as to lie all round centrally in it. Then concrete, prepared of 4 parts of gravel, 2 parts of clean sand, and 1 part of cement, mixed twice in a dry state and twice again with water, should be poured into its end and rammed by means of a small wooden handle so as to push the material evenly in every corner and recess. Stone metal and gravel above the size of  $\frac{3}{8}$  inch are unsuitable as they do not penetrate into corners and assume a flat surface. The excess material should be removed and top flat by wiping the top with a straight metal edge. There is no necessity of a covering plank for the top of the mould. After 6 hours the mould should be covered with moist gunny cloth, and left for 24 hours, when the sides of the mould could be taken apart to pieces. After another 24 hours the frame could be bodily lifted up and the bottom plank of the mould removed and used for preparing another frame. If sand and gravel of small size are used, the surface becomes smooth obviating the necessity of plastering it. Should the surface present a rough appearance, a coating of cement one part and fine sand two parts mixed in water should be applied with a flat brush. The frame thus prepared should be kept covered under moist gunny cloth for one week. If possible, it should preferably be kept immersed in water in a tank or a pond for that period.

For fixing the hinges, rough wooden lugs should be nailed inside the frame at the places of hinges, before concrete is poured so that there would be hollows left at those places in the frame. These may be filled afterwards with concrete made of 4 parts of coke breeze and one part of cement; when this sets it admits of hinges being fixed by means of ordinary screws, as if in wood.

Whereas a teak frame costs about Rs. 12/- per cubic foot including labour, the above frame costs Rs. 6/- per cubic foot including labour and the cost of the mould distributed over 16 frames, besides being permanent and proof against fire, white ants and dry rot.

# Index

- Acid soils 170  
Advantages of earth walls 37  
do. do. bricks 10  
do. do. mud flooring 72  
*Ain* 12  
Air as heat insulator 80  
Alkali soils 170  
Alterations and repairs 141  
Anærobic bacteria 113  
Annointment with oil 101  
Anopheles 176  
Ants white 55, 181  
Antiseptics 138  
Aroido plant 2
- Bamboo matting 80  
Basement floor 22, 28, 167  
Basket system 105  
Bath room 138  
Beams over *pise* walls 48  
do. rolled steel—Table of 71  
Bihar earthquake 38  
Bharatpur Fort 40  
Bilevaccine pills 174  
Bin in kitchen 167  
Black cotton soil 18, 92  
Bleaching powder 133  
Boiling water 132  
Bore wells 130  
Bore hole latrine 107  
Boxing for *pise* walls 46  
Brackish water 128  
Brick arches 64  
Brick *vs.* stone 9  
Brushing teeth 168  
Bugs 137  
Bureau of Standards 29, 51
- Capillary attraction 25  
Capture of Bharatpur 40  
Carbon dioxide 95  
Cellars 22  
do. leaks in 143  
do. making water-tight 23  
Cement asbestos sheets 80  
Census report 4  
*Chabuttra* 145
- Cheap materials—effect of 6  
Chemical water purifiers 132  
Check list of health questions 167  
Chlorogen 134  
Cholera 1, 88, 94, 172  
Chopan 16, 51  
C. I. Sheet 80  
C. I. sheets roof 80, 81, 85  
Clay lumps 34  
Cleaning bedding 137  
Closet 91  
Coal-tarring 56  
Cob work 39  
do. corners for 42  
Colours heat preventing 79  
Combermere 40  
Composite walls 33  
Composition of dust 93  
do. do. air 96  
Concrete walls 33  
do. floors 73  
do. terraces 85  
Conservancy system 105  
Consumption 178  
Contamination of water 129  
Coping of plinth 21  
Costs 144  
Cost of brickwork 11  
Country tiles 79  
Cow dung cakes 2  
do. disposal of 122  
Crude oil 56, 111  
Cross ventilation 99  
Culex 176  
Cut stone steps 165  
Cupboards 62  
do. below windows 60
- D. D. T. 140  
Damp 2, 7, 16, 24, 91, 125, 165  
do. sources of 24  
do. remedies for 25  
Damp-proof course 26  
do. from roofs 27  
Deep wells 130  
Defective drainage 26  
Deodorants 138

- Disinfectants 138  
 Disinfecting with sunlight 138  
 Distillation of water 131  
 Disadvantages of brick 11  
 Disposal of cow and horse dung 122  
   do. do. dry refuse 126  
   do. do. faecal matter 88  
   do. do. slop water 125  
   do. do. sewage 102  
   do. do. urine 122  
 Domestic sanitation 87  
 Doors 57  
   do. light 58  
 Drains 2, 125  
 Defective drainage 28  
 Draught 97, 99  
 Dry refuse 128  
 Dry rot 12, 28, 169  
 Duration of life 1  
 Dust 88, 93, 136  
 Dusting carpets 136  
 Dysentery 88  
  
 Eaves 37  
 Earth closet 108  
 Earthquake 38  
 Earth auger 107  
 Earth walls 37  
   do. methods of 37  
 Earthen rampart 40  
 Economy 7, 9  
   do. in founds 18, 20  
   do. in doors 57  
   do. in windows 59  
   do. in lintels 63  
   do. in plastering 76  
   do. in roof 82  
 Eczema 168  
 Enteric Fever 174  
 Epidemics 1  
 Exchange of bases 170  
 Expectoration 180  
  
 Fat lime 13  
 Faecal matter 88  
 Filling founds 20  
 Filtering water 132  
 Fire proof staircase 65, 168  
 Fixing C. I. sheets 81, 83  
 Flagstone wall 52  
 Flat roof 78, 83  
 Flat arches 60  
 Fleas 138  
 Flies 3, 103, 111, 124  
  
 Flooring suspended 68  
   do. ground 71  
 Frame of doors 58  
 Framed structure 28  
 Footings of walls 19  
 Foundation 18  
 Fumigation by sulphur vapour 139  
 Function of the door 58  
   do. of partition 63  
  
 Garbage 168  
*Geru* 51  
 Glass for partition 63  
 Grass matting 80  
  
 Habits of people 87  
 Hardness of water 128  
 Headers 31  
 Heat absorption by bricks 10  
 Heat prevention 79  
 Healing powers of sun 138  
 Hessian fabric 53  
 Hints for economy 9, 18, 20, 57, 61, 75, 79  
 Hipped roof 42  
 Hollows in walls 32  
 Horse dung 122  
 House cleaning 135  
 Humus 112  
 Hurmuz 51  
 Hydraulic lime 13  
  
 I-beams 29  
 Ideal latrine 89  
 Impervious earth 17  
 Impurities in water 128  
 Incinerator 127  
 Indian Patent stone 73  
 Infantile diarrhoea 88  
 Infra-red-rays 100  
 Inlet air openings 99  
 Inoculation against cholera 173  
   — do. do. plague 174  
   do. do. typhoid 175  
 Insulation from heat 79  
 Izal 139  
  
 Jack arch flooring 70  
 Jambs 48  
 Jats 40  
 Joists wooden for flooring 71  
   do. steel in frame work 29  
  
 Karvi 84  
*Khari mitti* 16  
 Kitchen floor 179

- Latrine 2, 89, 109, 111  
 Leaching salts 16  
 Lead washers 83  
 Lead paints 83, 166  
 Leaf of floors 58  
 Lintels 48, 63  
 Light 87, 100  
 Liquefaction 113  
  
 Malaria 1, 94  
 Mangalore tiles 79  
 Manure pits 123, 124  
 Materials 9  
 Mineral water impurities 128  
 Moisture in earth 46  
 Mortar 13  
 Mosquitoes 3  
 Muck heap 2, 129  
 Mud 6, 14, 39, 76, 85  
 Mud mortar 15  
   do. walls 39  
   do. plaster 76  
   do. roof 84  
   do. floor 2, 72  
*Multan mitti* 137  
 Municipal latrine 89  
*Murum* floor 2, 72  
  
*Neem* 12  
*Nhani* trap 126  
*Nirmali* 132  
 Nitre in earth 16  
 No-Frango partitions 63  
   do. roof 82  
   do. walls 53  
 Nuisance of flies 103  
  
 Object of founds 18  
 Oil annointment 101  
 Organic impurities 128  
   do. air do. 96  
 Overlap of C. I. Sheets 83  
 Origin of cholera 172  
   do. do. plague 173  
   do. do. typhoid 174  
   do. do. Malaria 175  
 Overcrowding in India 3, 94  
 Oxidation 113, 133  
 Oxygen in water 129  
  
 Painting wood 165  
 Palatability of water 128  
 Paper kerchief 180  
 Parapet 2, 84, 169  
 Paring instrument 41  
 Partition walls 63  
  
 Paving verandah 165  
*Peeli mitti* 51  
 Personal hygiene 168  
 Pesterine 139  
 Phenyle 139  
*Pise* wall 43, 45  
 Plague 173  
 Plans 144  
 Planning roof timbers 83  
 Plastering 15, 36, 76  
 Plaster on brick wall 10, 76  
   do. on *pise* wall 48  
 Plinth 21, 45  
 Plum concrete 21  
 Pointing composite wall 36  
 Poisonous dust 87, 93  
 Pool of water 167  
 Portable latrine 111  
 Position of staircase 133  
 Potassium Permanganate 133  
 Practical suggestions 82  
 Preservation of C. I. Sheets 80  
 Prevention of damp 24, 91  
   do. do. dust 93  
   do. do. white ants 55  
   do. do. rats 55  
   do. do. cholera 173  
   do. do. plague 174  
   do. do. typhoid 174  
   do. do. small-pox 175  
   do. do. small pox 175  
   do. do. Malaria 176  
 Pthisis 179  
 Public latrines 88  
*Purdah* system 94, 112  
 Purification of water 132  
  
 Quick lime 138  
 Quinine 178  
  
 Rain water 131  
 Rammers 47  
 Ramming *pise* wall 45  
 Rampart of earth 40  
 Rates 111  
 Rats 2, 55  
 Rat proofing 55, 81  
 Refuse 87, 127  
*Regur* 92  
*Reh* 17  
 R. C. C. beams for founds 19  
   do. door and window frames 57, 181  
   do. lintel 64  
   do. staircase 66  
   do. brick lintels 64

- Remedies against damp 25, 92  
   do.     do.    heat 79  
 Religious prejudices 88  
 Requirements of good earth 15  
   do.     of ideal latrine 89  
 Repairs and alterations 141  
   do.   do. cracks 142  
   do.   do. plaster 143  
 Roof 78  
   do. flat 83  
   do. advantages of pent 79  
   do. No-Frango 82  
   do. over cobwall 42  
   do. over *pise* wall 49  
 Rough cast plaster 51  
 Rollier 100  
 Rural latrine 106  
  
 Sand foundations 19  
 Sand—proportion in mortar 14  
 Sand filters 132  
 Sanitation domestic 87  
 Salt in sea-breeze 80  
 Salt in earth 16, 27  
 Salts in water 128  
 Sanitary paint for walls 137  
*Samalu* 84  
*Sarkand* 84  
 Scavengers 88, 105  
 Self-purification of rivers 129  
 Septic tank 113  
 Sewage 2, 88, 104  
 Sewage contamination of water 129  
 Shallow wells 130  
 Shelves of cupboards 62  
 Sink in kitchen 125  
 Single-leafed doors 57  
 Slates 79  
 Slop water 26, 125  
 Sloping site 19  
 Slop basin emptying 126  
 Small-Pox 175  
 Sodiumising clay 17, 77  
   do.   for plaster 48, 77  
 Sodium salts 17  
 Softness of water 128  
 Solarium 100  
 Solignum 177  
 Sound-proof walls 63  
 Sources of damp 24  
   do.   contamination in wells 131  
   do.   water 130  
 Sparklingness of water 128  
 Specifications 152  
 Speed of *pise* work 48  
  
 Spitting 178  
 Spring water 131  
 Sputum 190  
 St. Loe Strachey 43  
 Steel girder spacing 71  
 Steel framework 28  
 Steel joists as purlins 81  
 Staircase 2, 65  
 Staircase-dusting 136  
 Stiffness of wood 13  
   do.   of earth 36  
 Stock sizes of joists 165  
 Stone lintel 64  
 Stress in walls 13  
 Stretcher course 34  
 Stuffiness in cellars 22  
 Sullage water 125  
 Sulphur fumigation 139  
 Sun's rays 101, 180  
 Sun-dried bricks 38  
 Sunlight as disinfectant 100, 167  
*Surkhee* 14  
 Suitable soils for *pise* 44  
 Surfacing concrete terraces 85  
 Sweepers 88, 105  
 Symptoms of cholera 172  
   do.   of plague 173  
   do.   of Typhoid 174  
   do.   of Small-pox 175  
   do.   of Malaria 175  
  
 Table of steel girders for beams 71  
 Tahakhana 22  
 Tamping plaster 76  
 Tata Iron and Steel Co. 79  
 Terraces concrete 85  
 Tests for good earth 45  
 Teak 11  
 Thatch 79  
 Through ventilation 99, 167  
 Thickness of brick wall 10  
   do.   do. mud wall 39  
   do.   do. cob wall 42  
 Timber 9  
 Toilet room 137  
 Trench latrine 109  
 Transport-elimination of 6  
 Trap 117, 126  
 Tuberculosis 178  
 Typhoid 94, 174  
  
 Ultra-violet rays 100  
 Under-ground cupboard 62  
 Urinal 2  
 Urine-disposal of 122

- Usar lands 17  
Using open air 104  
Vaccination 175  
Ventilation 87, 94  
    do. of cellars 23  
    do. meaning of 94  
    do. different means of 97  
    do. through 99  
Verandah 83  
Volunteer organisation 89  
Walls 28  
    do. of stone 31  
    do. of B. brick 32  
    do. of concrete 33  
    do. of earth 37  
    do. of cob 39  
    do. partition 63  
    do. *pise* 43  
Walls of wattle and daub 51  
    do. flagstone 52  
    do. of No-Frango 53  
Wall plate 82  
Waller—J. H. de 53  
Water carriage system 106  
Water borne diseases 129  
Water supply 128  
Water proofing surface 50  
Watering composite wall 36  
Well 3, 130  
White earth 16  
    do. making artificially 16  
White ants 55, 181  
Width of foundations 19  
Windows 3, 59, 99  
    do. in cellars 23  
Zinc paints 166

BY THE SAME AUTHOR

# MODERN IDEAL HOMES FOR INDIA

REVISED & ENLARGED EDITION ( Rs. 12/50; Postage Re.2/- )

*A faithful and thorough guide to planning for Health, Comfort, and Happiness, consistent with Economy and with a special reference to the tropical climate and social customs of India, 330 pages of Art paper, over 110 plans of well-designed Homes, 310 large-sized illustrations, attractively bound.*

## CONTENTS

Foreword by Sir M. Visvesvaraya.	(XI) Plants in rooms.
(I) What should a Home Cost ?	(XII) Interior Decoration.
(II) Avenues of Economy.	(XIII) Colour Schemes.
(III) Selection of Site.	(XIV) Insulation or Heat-proofing.
(IV) Orientation for Comfort & Health.	(XV) Air-conditioning.
(V) Principles underlying Planning of a Home.	(XVI) Sound-proofing.
(VI) Analysis of a ' Home'.	(XVII) Specification of an 'Ideal Home.'
(VII) Synthesis of a ' Home'.	(XVIII) Introduction to Plans.
(VIII) Modern Architecture.	(XIX) Plans with Artistic Elevations of Bungalows, Storeyed Cottages, Flats etc. 110 in number with detailed notes on each.
(IX) Landscape Gardening.	(XX) Index.
(X) Furniture & Furnishing.	

SIR M. VISVESVARAYA says in his Foreword to the book, "...This up-to-date book on house-design and house-planning comes as a timely addition to our scanty technical information in this country....."

"The book gives a large variety of plans and views to suit all tastes and purses. The author, had, before writing it, equipped himself for the task, first by extensive practice in building Indian homes, and later, by travelling in Western Countries and Japan....."

"The book should prove a welcome guide to persons anxious to secure comfortable and attractive homes at moderate cost as well as to Contractors, Co-operative Societies, etc....."

*Copies available from Booksellers or from :*

**UNITED BOOK CORPORATION**

SARASWAT COLONY, POONA 2